



# Notes of Installation, Use, and Maintenance Front Mount TorqueMaster® Plus 6" Low Headroom

Wayne-Dalton Europe  
1 Rue Maurice Hollande  
51100 Reims, France  
www.waynedaltoneurope.com  
OR

Wayne-Dalton Corp.  
P.O. Box 67 Mt. Hope,  
OH 44660 - USA  
www.wayne-dalton.com

Models: Wayne-Dalton Prestige<sup>+</sup> / 40 mm / 9500

**NOTE:** This Notes of Installation, Use, and Maintenance Manual must be accompanied by the Drawings of Installation, Use, and Maintenance Manual, part #320407.

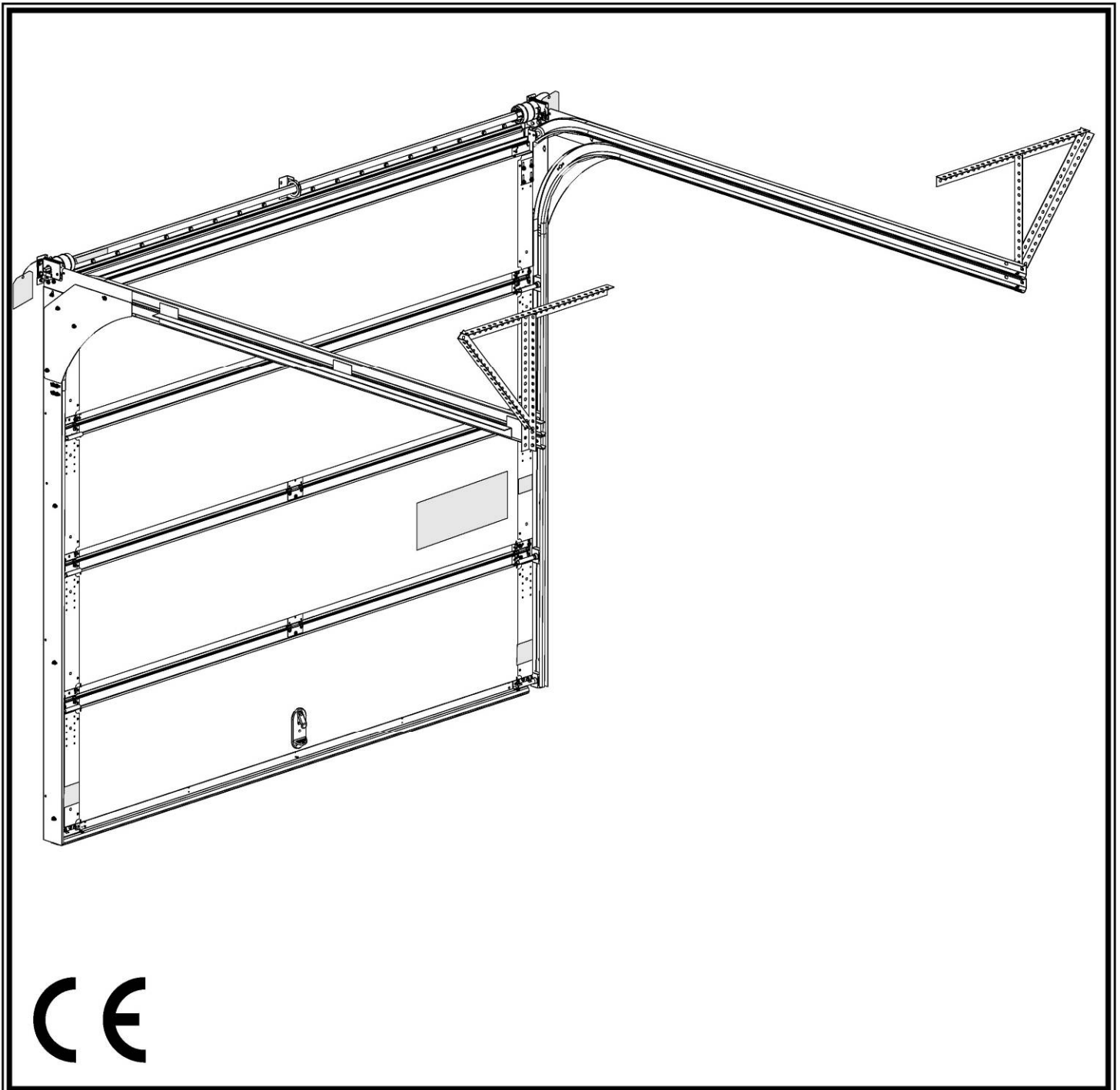

# TABLE OF CONTENTS

## *Notes of Installation, Use, and Maintenance*

Definition Of Symbols.....	3.
Important Safety Instructions For Installation.....	3.
Package Contents .....	4.
Required Tools .....	4.
Available Accessories.....	4.
<b>“INSTALLATION”</b>	
Vertical Seal .....	5.
Operator Bracket .....	5.
U-Bars .....	5.
Counterbalance Cable / Roller Shields .....	6.
Wall Angle / Levelling Bottom Section .....	6.
Header Seal .....	6.
Re-Installing Vertical Track .....	6.
Stacking Sections .....	7.
Horizontal Track .....	7.
LHR Top Bracket / Top Section .....	7.
Front Support Bracket.....	8.
Center Bracket Bushing Assembly.....	8.
Drum Wraps .....	8.
Cable Drums .....	8.
End Brackets.....	8.
Securing Center Bracket .....	8.
Adjusting Cable .....	9.
Winding Springs .....	9.
Rear Hangers.....	10.
Front Track Shield.....	11.
Roller Stop.....	11.
Step Plate / Lift Handle .....	12.
CE / Serial Number Label .....	12.
Typical Door Arm Attachment .....	12.
<b>“OPERATION USE”</b> .....	12.
<b>“MAINTENANCE”</b>	
Service / Repair.....	13.
TorqueMaster® Plus Reset Instructions.....	13. - 14.
Dismantle / Discard .....	14.
Semi-Annual Maintenance .....	15.
Maintenance / Painting.....	15.
<b>“REPLACEMENT”</b>	
Spring .....	16.
Header Seal .....	17.
Vertical Seal .....	17.
Astragal .....	17.
Limited Warranty .....	18.
Manufacturer’s Declaration Of Conformity .....	19.
Website.....	19.

## DEFINITION OF SYMBOL



ATTENTION - Risk Of Injury



**IT IS VITAL FOR THE SAFETY OF PERSONS TO FOLLOW ALL INSTRUCTIONS.**

1. READ AND FOLLOW ALL INSTALLATION INSTRUCTIONS.
2. Wear eye protection to prevent eye injury, when using tools to install, repair, or adjust door.
3. To avoid hand injury, wear protective gloves to install, repair, or adjust door.
4. The door should not be installed and is not intended for use in an explosive environment.
5. Door is under extreme spring tension. To prevent possible injury, repairs or adjustments not covered in this manual should only be performed by a qualified door person.
6. Operate door only when properly installed, properly adjusted, and free of obstructions.
7. The door should not be installed in a corrosive environment.
8. The door is designed to operate in an ambient temperature range of -40°C (-40°F) to 57°C (135°F).
9. **SAVE THESE INSTRUCTIONS.**

**NOTE:** Use these Notes of Installation, Use, and Maintenance in conjunction with the Drawings of Installation, Use, and Maintenance to perform the installation. The following letters & numbers in parenthesis, [example:(A1)] cross reference items listed in each diagram of the Drawings of Installation, Use, and Maintenance manual.

## Package Contents

### Package Contents “A” (See page 2 of *Drawings of Installation, Use and Maintenance manual*)

PARTS	QUANTITY	PARTS	QUANTITY
<b>A1.</b> Bottom Section	1	<b>A23.</b> U-Bars	
<b>A2.</b> Lock Section	1	(9500 / 40mm series doors only)	As Required
<b>A3.</b> Intermediate Section	As Required	<b>A24.</b> Wall Angle / Vertical Track Assembly	1 Pair
<b>A4.</b> Top Section	1	<b>A25.</b> Roller Stop	1
<b>A5.</b> Front Support Brackets	1 Pair	<b>A26.</b> ø6.35 x 15.88mm (1/4" - 14 x 5/8")	
<b>A6.</b> Horizontal Track Assembly	1 Pair	Self- Tapping Screw	As Required
<b>A7.</b> Front Track Shield	1 Pair	<b>A27.</b> Operator Bracket	1
<b>A8.</b> Header Seal	1	<b>A28.</b> ø6.35 x 17.46mm (1/4"-20x11/16")	
<b>A9.</b> Vertical Seal	1 Pair	Self-Drilling Screw	As Required
<b>A10.</b> Rollers	As Required	<b>A29.</b> ø7.94 x 41.28mm (5/16" x 1-5/8")	
<b>A11.</b> LHR Top Brackets	1 Pair	Lag Screw	As Required
<b>A12.</b> Roller Shield	As Required	<b>A30.</b> ø6.35 (1/4" – 20)	
<b>A13.</b> Outside Step Plate	1	Flange Hex Nut	As Required
<b>A14.</b> Inside Step Plate	1	<b>A31.</b> Loose Winding Shaft	
<b>A15.</b> Labels		(Single Spring Doors Only)	1
<b>A15.1</b> Yellow and Black Warning Label	1	<b>A32.</b> ø4.17 x 41.28mm (#8 x 1 5/8")	
<b>A15.2</b> Bottom Bracket Warning Labels	2	Phillips Head Screws	2
<b>A15.3</b> TorqueMaster® Warning Tags	2	<b>A33.</b> ø7.94 x 19.05mm (5/16" - 18 x 3/4")	
<b>A16.</b> TorqueMaster® Tube	1 Assembly	Carriage Bolt	As Required
<b>A17.</b> Cable Drum Assembly	1 Pair	<b>A34.</b> ø7.94 (5/16" - 18)	
<b>A18.</b> Drum Wraps	1 Pair	Hex Nut	As Required
<b>A19.</b> End Bracket - LH	1	<b>A35.</b> ø7.94 x 31.75mm (5/16" x 1 1/4")	
<b>A20.</b> End Bracket - RH	1	Clevis Pin	1
<b>A21.</b> Center Bracket Assembly	1	<b>A36.</b> Hairpin Cotter	1
<b>A22.</b> ø6.35 x 14.29mm (1/4" - 20 x9/16")			
Track Bolt	As Required		

### Tools Required “B” (See page 3 of *Drawings of Installation, Use and Maintenance manual*)

PARTS	QUANTITY	PARTS	QUANTITY
<b>B1.</b> Electric Drill (With Clutch)	1	<b>B12.</b> 16 mm (5/8") Wrench	1
<b>B2.</b> 11 mm (7/16") Hex Head Driver	1	<b>B13.</b> 76 mm (3") Extension	1
<b>B3.</b> 11 mm (7/16") Drill Bit	1	<b>B14.</b> 16 mm (5/8") Socket	1
<b>B4.</b> 5 mm (3/16") Drill Bit	1	<b>B15.</b> Locking Pliers	2
<b>B5.</b> 7 mm (9/32") Drill Bit	1	<b>B16.</b> Hammer	1
<b>B6.</b> Ratchet Wrench	1	<b>B17.</b> Step Ladder	1
<b>B7.</b> Tape Measure	1	<b>B18.</b> Pencil	1
<b>B8.</b> Pliers	1	<b>B19.</b> Saw Horses	2
<b>B9.</b> Screw Driver (Flat Head)	1	<b>B20.</b> Safety Glasses	1
<b>B10.</b> Screw Driver (Phillips Head)	1	<b>B21.</b> Gloves	1
<b>B11.</b> 11 mm (7/16") Wrench	1	<b>B22.</b> Level	1
		<b>B23.</b> Vice Clamps	As Required

### Available Accessories “C” (See page 3 of *Drawings of Installation, Use and Maintenance manual*)

PARTS	QUANTITY	
<b>C1.</b> Secure Lock	1	<b>NOTE:</b> Install the Secure Lock (C1) or Inside Side Lock (C2) after door is completely installed and functional, using the Notes and Drawings of Installation, Use, and Maintenance Manual.
<b>C2.</b> Inside Side Lock	1	

# Installation

Begin the installation of the door by checking the opening. **The door should be approximately 40mm (1 1/2") wider than the opening.** Vertical jambs must be plumb and the header level. Side clearance, from edge of door to wall, must be minimum of 127mm (5") on each side. Follow the steps below.

**NOTE:** Side clearance may vary depending on the type of tool being used.

**IMPORTANT! Stainless steel lag screws or PT2000 coated lag screws MUST be used when installing center bearing brackets, end bearing brackets, jamb brackets, operator mounting/ support brackets and disconnect brackets on treated lumber (preservative-treated). Stainless steel or PT2000 coated lag screws are NOT necessary when installing products on un-treated lumber.**

**NOTE:** Pilot drilling, using a 5mm (3/16") drill bit (B4), is recommended when fastening  $\varnothing 7.94 \times 41.28\text{mm}$  (5/16" x 1 5/8") lag screws (A29) into wood structure.



**IMPORTANT! Right and left hand is always determined from inside the building looking out.**

<b>STEP 1</b>	<b>Vertical Seal</b> (See Diagram 1 on page 4 of Drawings of Installation, Use and Maintenance manual)
<u>Tools Needed</u> (B7) (B9) (B11)	Remove vertical track (1a) from wall angle assembly (A24) by removing the $\varnothing 6.35 \times 14.29\text{mm}$ (1/4" - 20 x 9/16") track bolts (A22) and $\varnothing 6.35$ (1/4" - 20) flange hex nuts (A30); set aside. Before attaching the vertical seal (A9), measure and cut the vertical seal to your door opening height plus 25 mm (1"). Align profiles of the vertical seal and wall angle (1b). Next, slide vertical seal over the wall angle until vertical seal is flush with opposite end.
<b>STEP 2</b>	<b>Operator Bracket</b> (See Diagram 2 on page 4 of Drawings of Installation, Use and Maintenance manual)
<u>Tools Needed</u> (B1) (B2) (B9)	<p><b>IMPORTANT! When installing a trolley operator, operator bracket (A27) must be mounted and secured prior to installing top section (A4).</b></p> <p><b>IMPORTANT! When connecting a trolley type garage door opener to this door, a Wayne-Dalton opener / trolley bracket must be securely attached to the top section of the door, along with any u-bars provided with the door. The installation of the opener must be according to manufacturer's instructions and force settings must be adjusted properly.</b></p> <p>Locate the center of the top section (A4) and seat the operator bracket (A27) on male part of top section (1c). The operator bracket must be centered and positioned on the top section so it bridges the transition point of the section thickness. Attach the operator bracket using (8) <math>\varnothing 6.35 \times 15.88\text{mm}</math> (1/4" - 14 x 5/8") self-tapping screws (A26) as shown.</p>
<b>STEP 3</b>	<b>U-Bars</b> (See Diagram 3 on page 4 of Drawings of Installation, Use and Maintenance manual)
<u>Tools Needed</u> (B1) (B2) (B7)	<p><b>NOTE:</b> If the door was not supplied with u-bars (A23), skip this step.</p> <p><b>NOTE:</b> 9500 / 40 mm doors 3,68 m (12' - 1") wide or greater will be supplied with u-bars (A23) for the top (A4), intermediate(s) (A3), lock (A2), and bottom section (A1).</p> <p>With the sections laying flat on a smooth surface, center a u-bar on top of each section and flush with edge of section. Fasten each end of the u-bars to the endcap (1d) with two <math>\varnothing 6.35 \times 17.46\text{mm}</math> (1/4" - 20 x 11/16") self-drilling screws (A28) (Two <math>\varnothing 6.35 \times 17.46\text{mm}</math> (1/4" - 20 x 11/16") self-drilling screws through the operator bracket (C1), if applicable) and <math>\varnothing 6.35 \times 15.88\text{mm}</math> (1/4" - 14 x 5/8") self-tapping screws (A26) every 762 mm - 914 mm (30" - 36" inches) (1f) intervals across the section.</p>

<b>STEP 4</b>	<b>Counterbalance Cable / Roller Shields</b> <b>(See Diagram 4 on page 5 of Drawings of Installation, Use and Maintenance manual)</b>
<u>Tools Needed</u> (B7)	<p>TorqueMaster® drums (A17) are marked right and left. Make sure you place the cable from the right hand drum on the right hand milford pin and the cable from the left hand drum on the left hand milford pin. Uncoil the counterbalance cables and slip the loop (1g) at the ends of the cables over the milford pins (1h) on the bottom section (A1). Place roller shields (A12) on each of the rollers (A10). Insert a short shaft roller in the bottom bracket (1i) on the bottom section and another short shaft roller in the #1 end hinge (1j) at the top of the bottom section. Repeat for other side.</p> <p><b>NOTE:</b> 9500 / 40mm series doors 3,68 m (12' - 1") wide or greater will use a long shaft roller(s) (1k) with double wide end hinges (1l).</p> <p><b>NOTE:</b> The bottom section can be identified by a #1 end hinge and the factory attached bottom astragal (1m). Place a bottom bracket warning label (A15.2) on each end stile (1d) close to the bottom bracket.</p> <p><b>NOTE:</b> Verify that astragal does not protrude more than 13 mm (1/2") past ends of the bottom section. If excess needs to be trimmed off, be careful not to stretch astragal, or it may end up shorter than section width.</p>
<b>STEP 5</b>	<b>Wall Angle / Levelling Bottom Section</b> <b>(See Diagram 5 on pages 5 &amp; 6 of Drawings of Installation, Use and Maintenance manual)</b>
<u>Tools Needed</u> (B1) (B2) (B7) (B22)	<p>Center the bottom section (A1) in the door opening (1n). Place a level on the bottom section to determine if the section is level. If needed, level it using wooden shims (1o) under the bottom astragal.</p> <p><b>NOTE:</b> Make sure the counterbalance cable (A17) is located between the rollers (A10) and the door jamb (1p).</p> <p><b>IMPORTANT! The tops of the wall angles (1b) must be level from side to side. If the bottom section was shimmed to level it, then the wall angle on the shimmed side, must be raised the height of the shim.</b></p> <p>Place the left hand wall angle on the left side of the door jamb (1p). Position the wall angle (1b) 43 mm (1-11/16") (1q) from the edge of the bottom section. Plumb the wall angle vertically with the level and secure it to the door jamb with <math>\varnothing 7.94 \times 41.28\text{mm}</math> (5/16" x 1-5/8") lag screws (A29) through each slot. Repeat for right hand side. After fastening the right hand side to the door jamb, lay the bottom section down and install any remaining <math>\varnothing 7.94 \times 41.28\text{mm}</math> (5/16" x 1-5/8") lag screws in the wall angle. If fastening into concrete, proper anchors (1r) will need to be used.</p> <p>Stand the bottom section up and center in the door opening. Re-check bottom section for level. Hang cable drums over top of wall angles.</p>
<b>STEP 6</b>	<b>Header Seal</b> <b>(See Diagram 6 on page 7 of Drawings of Installation, Use and Maintenance manual)</b>
<u>Tools Needed</u> (B1)(B2) (B7) (B22)	<p>Measure between the vertical (A9) seals and cut header seal (A8) to length. Place the header seal flush against the vertical jamb seals (1s) and level header seal. To secure the header seal, place a <math>\varnothing 7.94 \times 41.28\text{mm}</math> (5/16" x 1-5/8") lag screw (A29) in each slot location over the entire length of the header seal. If fastening into concrete, proper anchors (1r) will need to be used.</p>
<b>STEP 7</b>	<b>Re-Installing Vertical Track</b> <b>(See Diagram 7 on page 7 of Drawings of Installation, Use and Maintenance manual)</b>
<u>Tools Needed</u> (B9)(B11)	<p>Slide vertical track (1a) over the roller shields (A12) and roller (A10) (1k). Loosely fasten vertical track (1a) to the wall angle (1b) using <math>\varnothing 6.35 \times 14.29\text{mm}</math> (1/4" - 20 x 9/16") track bolts (A22) and <math>\varnothing 6.35</math> (1/4" - 20) flange hex nuts (A30) removed in <b>STEP 1</b>.</p>

STEP 8	<b>Stacking Sections</b> <b>(See Diagram 8 on page 8 of <i>Drawings of Installation, Use and Maintenance manual</i>)</b>
<u>Tools Needed</u> (B1) (B2)	<p><b>NOTE:</b> Make sure hinges are flipped down when stacking another section (A2 and A3) on top.</p> <p><b>NOTE:</b> The lock section can be identified by a #2 end hinge (1u) and the CE/SERIAL NUMBER LABEL (1v) attached to the right side of the section. Place the yellow and black warning label (A15.1) on the lock section as shown.</p> <p><b>NOTE:</b> The intermediate section can be identified by a #3 end hinges (1w) and are used on the third section of four section high doors.</p> <p><b>NOTE:</b> The intermediate section can be identified by a #4 end hinges (3l) and are used on the fourth section of five section high doors.</p> <p><b>NOTE:</b> The sequence is always determined by #1 end hinge being the bottom section (A1) to #3 or #4 being the highest intermediate section.</p> <p><b>NOTE:</b> 9500 / 40 mm series doors 3,68 m (12' - 1") wide or greater will use long shaft rollers (1k) with double wide end hinges (1l).</p> <p>Insert short shaft rollers (A10) / roller shields (A12) into both #2 end hinges of the lock section. With assistance lift section and place rollers / roller shields over the tops of the vertical tracks (1a). Install by guiding rollers / roller shields into the vertical track on both sides and gently lowering the section onto the bottom section (A1). Install remaining section(s), except for the top section (A4).</p> <p>Keeping sections vertically aligned, rotate the center hinge leafs (1x) upward and secure the center hinge leaf to the above section with three <math>\varnothing 6.35 \times 15.88\text{mm}</math> (1/4" - 14 x 5/8") self-tapping screws (A26). <b>NOTE:</b> To prevent center hinge leaf from rotating, first secure the top middle hole of center hinge leaf with one <math>\varnothing 6.35 \times 15.88\text{mm}</math> (1/4" - 14 x 5/8") self-tapping screw then secure the other two holes. Rotate the end hinge leaf upward and fasten the end hinge leaf to the above section with two <math>\varnothing 6.35 \times 15.88\text{mm}</math> (1/4" - 14 x 5/8") self-tapping screws. (<b>NOTE:</b> 9500 / 40 mm series doors with double wide end hinges (1l). Rotate both hinge leafs upward and secure to the above section with five <math>\varnothing 6.35 \times 15.88\text{mm}</math> (1/4" - 14 x 5/8") self-tapping screws.) Repeat for the opposite side. Now complete the vertical track installation on both sides by securing the <math>\varnothing 6.35 \times 14.29\text{mm}</math> (1/4" - 20 x 9/16") track bolts (A22) and <math>\varnothing 6.35</math> (1/4"- 20) flange hex nuts (A30).</p> <p><b>IMPORTANT! Vertical tracks (1a) must be secured so that the rollers (A10) are touching the curved part of the vertical track (1y).</b></p> <p><b>IMPORTANT! Push &amp; hold the hinge leaf(s) against section while securing with <math>\varnothing 6.35 \times 15.88\text{mm}</math> (1/4" - 14 x 5/8") self-tapping screws (A26).</b></p>
STEP 9	<b>Horizontal Track</b> <b>(See Diagram 9 on page 9 of <i>Drawings of Installation, Use and Maintenance manual</i>)</b>
<u>Tools Needed</u> (B9) (B11) (B22)	<p>Place the left hand horizontal track assembly (A6) on top of the left hand vertical track (1a). Align the slots of the horizontal track assembly with the corresponding slots in the wall angle assembly (A24). Loosely secure the horizontal track assembly to the wall angle assembly with three <math>\varnothing 6.35 \times 14.29\text{mm}</math> (1/4"-20x9/16") track bolts (A22) and <math>\varnothing 6.35</math>(1/4"-20) flange hex nuts (A30). Level the horizontal track assembly and tighten the three <math>\varnothing 6.35 \times 14.29\text{mm}</math> (1/4"-20x9/16") track bolts and <math>\varnothing 6.35</math> (1/4"-20) flange hex nuts. Repeat for other side.</p> <p><b>NOTE:</b> If an automatic garage door opener will be installed, position horizontal tracks slightly above level.</p> <p><b>IMPORTANT! Make sure there is a smooth transition between the horizontal track (A6) and vertical Track (1a).</b></p>
STEP 10	<b>LHR Top Bracket / Top Section</b> <b>(See Diagram 10 on page 10 of <i>Drawings of Installation, Use and Maintenance manual</i>)</b>
<u>Tools Needed</u> (B1) (B2) (B7)	<p>Install the left hand low headroom top bracket (A11) on the top section (A4). Align the upper slots of the top bracket with the second set of holes of the endcap (1d) and loosely fasten top bracket, using four <math>\varnothing 6.35 \times 15.88\text{mm}</math> (1/4" - 14 x 5/8") self-tapping screws (A26). Place the top section in door opening (1n) by inserting the left hand top roller (1z) in the upper horizontal track (2a), rotate the top section into position. Twist the right roller into the upper horizontal track and locate the top bracket against the section. Align the upper slots of the top bracket with the second set of holes of the endcap and secure the top bracket with four <math>\varnothing 6.35 \times 15.88\text{mm}</math> (1/4" - 14 x 5/8") self-tapping screws. Tighten the left hand low headroom top bracket.</p> <p><b>NOTE:</b> When installing the low headroom top bracket, the top section must be vertically aligned with the rest of the sections from the side view. Diagram [10.4] shows correct position; [10.5] shows incorrect position. If needed reposition top bracket to achieve vertical alignment.</p> <p>Align the top section with the lower sections (A1 thru A3) and fasten hinge leafs (1w and 1x) to the top section, as shown in <b>STEP 8</b>.</p> <p><b>NOTE:</b> Make sure the top section is vertically aligned with the lower sections (A1 thru A3) before securing the remaining hinge leafs.</p> <p>When installing a door with a TorqueMaster<sup>®</sup> counterbalance system, vertical wall angle alignment is critical. Position wall angles (1b) 44 mm (1-3/4") (2b) from the edge of the top section. Wall angles must be parallel to the door section ends.</p> <p><b>IMPORTANT! The dimension between the wall angles must be door-width plus 89 mm (3-1/2") (2c) for smooth, safe door operation.</b></p>

<b>STEP 11</b>	<b>Front Support Bracket</b> (See Diagram 11 on page 11 of <i>Drawings of Installation, Use and Maintenance manual</i> )
<u>Tools Needed</u> (B1) (B2) (B9) (B11)	Align the hole of the front support bracket (A5) with the slotted hole of the horizontal track assembly (A6). Fasten the front support bracket to the horizontal track assembly using one $\phi 6.35 \times 14.29\text{mm}$ (1/4" - 20 x 9/16") track bolts (A22) and $\phi 6.35$ (1/4" - 20) flange hex nut (A30). Secure the front support bracket to the door jamb using a $\phi 7.94 \times 41.28\text{mm}$ (5/16" x 1-5/8") lag screw (A29). If fastening into concrete, proper anchors (1r) will need to be used.
<b>STEP 12</b>	<b>Center Bracket Bushing Assembly</b> (See Diagram 12 on page 11 of <i>Drawings of Installation, Use and Maintenance manual</i> )
<u>Tools Needed</u> NONE	TorqueMaster <sup>®</sup> springs come lubricated and pre-assembled inside torque tube. To install, lay the tube on the floor in front of the door with the labeled (3e) end to the left. Being cam shaped the center bracket bushing (1t) only fits one way. Slide the center bracket assembly (A21) towards the center of the torque tube (A16), from the right side as shown.
<b>STEP 13</b>	<b>Drum Wraps</b> (See Diagram 13 on page 11 of <i>Drawings of Installation, Use and Maintenance manual</i> )
<u>Tools Needed</u> NONE	Drum wraps (A18) are identified as right and left. Slide the left hand drum wrap over the left side of the TorqueMaster <sup>®</sup> tube (A16) with the tabs (2e) facing left. Slide it towards the center of the torque tube. Place the right hand drum wrap on the opposite end of the TorqueMaster <sup>®</sup> tube with the tabs facing right. Slide it towards the center of the torque tube.
<b>STEP 14</b>	<b>Cable Drums</b> (See Diagram 14 on pages 11-12 of <i>Drawings of Installation, Use and Maintenance manual</i> )
<u>Tools Needed</u> NONE	Shake the torque tube (A16) gently to extend the winding shafts (2f) out about 127mm (5") on each side. <b>NOTE:</b> For single spring applications, there will be no left hand winding shaft in the TorqueMaster <sup>®</sup> tube. Lift torque tube and rest on top of the front support brackets (A5). Cable drums (A17) and torque tube are cam shaped to fit together only one way. To install the right hand cable drum, slide the drum over the winding shaft until the drum seats against the torque tube. The winding shaft must extend past the cable drum far enough to expose the splines (2g) and the groove (2h). Align the winding shaft groove with the round notch (2i) in the front support bracket. Repeat for opposite side for double spring applications. For single spring applications, insert the loose left hand winding shaft (A31) into the left hand drum prior to sliding the drum over the torque tube. Then align the winding shaft groove with the round notch in the front support bracket on the opposite end. <b>NOTE:</b> On single spring applications, take care in handling the loose winding shaft (A31) (left side) so that it does not slide back into the TorqueMaster <sup>®</sup> tube.
<b>STEP 15</b>	<b>End Brackets</b> (See Diagram 15 on page 12 of <i>Drawings of Installation, Use and Maintenance manual</i> )
<u>Tools Needed</u> (B1) (B2)	End brackets are right (A20) and left hand (A19). You can identify the right hand end bracket by the disconnect cable guide hole (3d) in the top of the bracket. Attach TorqueMaster <sup>®</sup> warning tags (A15.3) to both end brackets prior to installing. Beginning with the right hand side, slide the end bracket onto the winding shaft (2f) so that the grooves in the ratchet wheel (2j) fit onto the winding shaft splines (2g). Secure end bracket to the front support bracket using one $\phi 7.94 \times 19.05\text{mm}$ (5/16" - 18 x 3/4") carriage bolt (A33) and one $\phi 7.94$ (5/16" - 18) hex nut (A34). Secure end bracket to the front support bracket (A5) using one $\phi 6.35 \times 15.88\text{mm}$ (1/4" - 14 x 5/8") self-tapping screws (A26). Repeat for left hand end bracket.  <b>NOTE:</b> Ensure the $\phi 7.94 \times 19.05\text{mm}$ (5/16" - 18 x 3/4") carriage bolt is going through the end bracket first, and the $\phi 7.94$ (5/16" - 18) hex nut is on the outside of the front support bracket. <b>IMPORTANT!</b> If ratchet gear (2t) slips out of end bracket (A19, A20), ensure the teeth on ratchet wheel are pointing upward in a clockwise position when sliding it back inside the end bracket, as shown in Diagram [15.2].
<b>STEP 16</b>	<b>Securing Center Bracket</b> (See Diagram 16 on page 12 of <i>Drawings of Installation, Use and Maintenance manual</i> )
<u>Tools Needed</u> (B1) (B2) (B7) (B22)	To locate the center bracket assembly (A21), mark the header (2l) halfway between the wall angle assemblies and level the TorqueMaster <sup>®</sup> tube (A16). Fasten the center bracket assembly to the header using two $\phi 7.94 \times 41.28\text{mm}$ (5/16" x 1-5/8") hex head lag screws (A29). If fastening into concrete, proper anchors (1r) will need to be used.

<b>STEP 17</b>		<b>Adjusting Cable</b> (See Diagram 17 on page 13 of <i>Drawings of Installation, Use and Maintenance manual</i> )																											
<u>Tools Needed</u> (B8) (B9) (B15)	Clamp locking pliers onto both vertical tracks just above third roller to prevent door from rising while winding the counterbalance springs.																												
	 <b>Failure to clamp track can allow door to raise and cause severe injury.</b>																												
	Starting on the right side, adjust the cable drum assembly by rotating the drum (2m) until the set screw (2n) faces directly away from the header (2l). Loosen the set screw no more than 1/2 turn. Pull on the end of the cable (2o) to remove all cable slack.																												
	<b>NOTE:</b> Ensure the cable is aligned and seated in the first groove (2p) of the cable drum. Snug the set screw, then tighten an additional 1-1/2 turns. Cut off excess cable.																												
<b>STEP 18</b>		<b>Winding Springs</b> (See Diagram 18 on page 13 of <i>Drawings of Installation, Use and Maintenance manual</i> )																											
<u>Tools Needed</u> (B6) (B13) (B14) (B15) (B17) (B18) (B20) (B21)	Double check to ensure the counterbalance cable is aligned in the appropriate groove of the cable drum <b>STEP 17</b> . Starting with the right side, place a mark (2r) on winding shaft (2f) (or socket) and end bracket (A20). Turn the pawl knob on the end bracket to the upper position (2q). Using a ratchet with a 16 mm (5/8") socket, wind the spring by rotating the winding shaft counter clockwise, while watching the mark on the winding shaft.																												
	<b>(NOTE: A 76 mm (3") extension is also recommended for added clearance from the horizontal track assembly.)</b> <b>IMPORTANT! Pawl knob must be in upper position (2q) to add/remove required number of spring turns. After adding / removing spring turns, pawl knob must be placed back in lower position (2s).</b>																												
	 <b>It is recommended that leather gloves be worn while winding the TorqueMaster® Plus springs. Failure to wear gloves may cause injury to hands.</b>																												
	After 2-3 turns, remove the ratchet and adjust the cable on the left side ( <b>STEP17</b> ). Ensure the cable is in the appropriate groove of the cable drum and clear of any obstructions.																												
	<b>IMPORTANT! Counterbalance cable tension must be equal on both sides prior to fully winding springs.</b>																												
	See the <b>Spring Turn</b> chart.																												
	<b>FOR SINGLE SPRING APPLICATIONS:</b> Return to the right hand and continue winding the spring to the required number of turns for your door. Place pawl knob in lower position (2s).																												
	<b>FOR DOUBLE SPRING APPLICATIONS:</b> Place a mark on the winding shaft (or socket) and end bracket (A19). Place the ratchet with 16mm (5/8") socket onto the left hand winding shaft end. To wind the spring, rotate the winding shaft clockwise, while watching the mark on the winding shaft (or socket). Rotate the winding shaft to the required number of turns for your door. Then return to the right hand side and wind the right hand spring to the required number of turns. Place pawl knob in lower position (2s) on both sides.																												
	<b>NOTE:</b> Since total turns to balance door can deviate from spring turn chart values by ± 1-1/2 turns, adjustments to the recommended number of spring turns may be required <b>AFTER</b> rear hangers assembly is completed ( <b>STEP 19</b> ). To install drum wraps (A18), position the left hand drum wrap over the left hand drum, aligning groove in drum wrap towards the left until tabs (2e) snap over drum in between drum and ratchet gear (2t). Repeat for right hand side.																												
		<table border="1" style="width: 100%; text-align: center;"> <thead> <tr> <th colspan="2">Spring Turns</th> </tr> <tr> <th>Door Height</th> <th>Spring Turns</th> </tr> </thead> <tbody> <tr> <td>1,83m (6' - 0")</td> <td>14</td> </tr> <tr> <td>1,91m (6' - 3")</td> <td>14 - 1/2</td> </tr> <tr> <td>1,96m (6' - 5")</td> <td>15</td> </tr> <tr> <td>1,98m (6' - 6")</td> <td>15</td> </tr> <tr> <td>2,03m (6' - 8")</td> <td>15 - 1/2</td> </tr> <tr> <td>2,06m (6' - 9")</td> <td>15 - 1/2</td> </tr> <tr> <td>2,13m (7' - 0")</td> <td>16</td> </tr> <tr> <td>2,21m (7' - 3")</td> <td>16 - 1/2</td> </tr> <tr> <td>2,29m (7' - 6")</td> <td>17</td> </tr> <tr> <td>2,36m (7' - 9")</td> <td>17 - 1/2</td> </tr> <tr> <td>2,44m (8' - 0")</td> <td>18</td> </tr> </tbody> </table>		Spring Turns		Door Height	Spring Turns	1,83m (6' - 0")	14	1,91m (6' - 3")	14 - 1/2	1,96m (6' - 5")	15	1,98m (6' - 6")	15	2,03m (6' - 8")	15 - 1/2	2,06m (6' - 9")	15 - 1/2	2,13m (7' - 0")	16	2,21m (7' - 3")	16 - 1/2	2,29m (7' - 6")	17	2,36m (7' - 9")	17 - 1/2	2,44m (8' - 0")	18
Spring Turns																													
Door Height	Spring Turns																												
1,83m (6' - 0")	14																												
1,91m (6' - 3")	14 - 1/2																												
1,96m (6' - 5")	15																												
1,98m (6' - 6")	15																												
2,03m (6' - 8")	15 - 1/2																												
2,06m (6' - 9")	15 - 1/2																												
2,13m (7' - 0")	16																												
2,21m (7' - 3")	16 - 1/2																												
2,29m (7' - 6")	17																												
2,36m (7' - 9")	17 - 1/2																												
2,44m (8' - 0")	18																												

## STEP 19

### Rear Hangers

(See Diagram 19 on page 14 of *Drawings of Installation, Use and Maintenance manual*)

#### Tools Needed

(B1)  
(B2)  
(B6)  
(B12)  
(B13)  
(B14)  
(B17)  
(B20)  
(B22)

Hold the door down to prevent it from rising unexpectedly in the event the springs were overwound and carefully remove the locking pliers from the vertical tracks. Raise the door until the top section and half of the next section are in a horizontal position. Do not raise door any further since horizontal tracks (A6) are not yet supported at the rear.



Raising door further can cause door to fall, resulting in possible severe injury.

Clamp a pair of locking pliers to the vertical tracks just above the second roller on one side, and just below the second roller on the other side. This will prevent the door from raising or lowering while installing the rear hangers. Using perforated angle (2u),  $\varnothing 7.94 \times 41.28\text{mm}$  (5/16" x 1-5/8") lag screws (2v) and  $\varnothing 7.94 \times 25.4\text{mm}$  (5/16" - 18 x 1") hex bolts (2w) with  $\varnothing 7.94$  (5/16" - 18) nuts (2x), fabricate rear hangers for horizontal tracks.

**NOTE:** These items may not have been supplied. Attach horizontal tracks (A6) to the rear hangers with two  $\varnothing 7.94 \times 25.4\text{mm}$  (5/16" - 18 x 1") hex bolts and  $\varnothing 7.94$  (5/16" - 18) nuts. Place nuts on inside of tracks. Horizontal tracks must be level and parallel with edges of door.

Attach rear hangers to ceiling joist or other structurally sound framing members. Brace rear hangers as shown in *Drawings of Installation, Use and Maintenance manual*.

**NOTE:** If an automatic garage door opener will be installed, position horizontal tracks one hole above level when securing to the rear hangers.



Keep horizontal track parallel and within 19 mm (3/4") of door edge, otherwise door could fall, resulting in possible severe injury.

Lift the door and check its balance. Adjust spring tension, if door lifts by itself (also hard to pull down) or if door is difficult to lift (too easy to pull down). When adjusting spring tension, only add or remove a maximum of 3/10 of a turn (three teeth of ratchet wheel) at a time. Both sides need to be adjusted equally on double spring doors.

**IMPORTANT! Pawl knob must be in upper position (2q) to add / remove required number of spring turns. After adding / removing spring turns, pawl knob must be placed back in lower position (2s).**

**Add Spring Tension:** Place pawl knob in upper position. The ratchet wheel (2t) is made of 10 teeth. To add spring tension, ensure the ratchet and socket is set so that it will tighten counter clockwise on the right hand side, and clockwise on the left hand side. Place the ratchet with 16 mm (5/8") socket onto the winding shaft (2f), pull down to add 3/10 of a turn. Watch as three teeth of the ratchet wheel pass over the pawl (1e), creating three "clicks". Place pawl knob in lower position.

**Remove Spring Tension:** Place pawl knob in upper position. To remove spring tension, ensure the ratchet and socket is set so that it will tighten counter clockwise on the right hand side and clockwise on the left hand side. It is recommended that a regular 16 mm (5/8") wrench be used. Place the wrench onto the winding shaft. Pull down on the wrench to relieve pressure between the pawl and the ratchet wheel. Push in on the pawl (1e) to allow the three ratchet wheel (2t) teeth to pass by the pawl, as you carefully allow the wrench to be rotated upward by the spring tension. Release the pawl (1e) to allow it to engage with the ratchet wheel. Place pawl knob in lower position.



Be prepared to hold the full tension of the spring.



Do not add or remove more than 1 1/2 spring turns (1 spring turn equals 10 teeth on ratchet wheel) from the recommended number of turns per the spring turn chart.

If the door still does not operate easily, lower the door into the closed position, UNWIND SPRING(S) COMPLETELY, and recheck the following items:

- 1.) Check the door for level.
- 2.) Check the torque tube, wall angles, and horizontal tracks for level.
- 3.) Check the distance between the wall angles. It must be door width plus 90 mm (3-1/2").
- 4.) Check the cables for equal tension. Loosen set screws and adjust if necessary.
- 5.) Rewind both springs.
- 6.) Make sure door is not rubbing on jamb.

<b>STEP 20</b>	<b>Front Track Shield</b> <b>(See Diagram 20 on page 14 of <i>Drawings of Installation, Use and Maintenance manual</i>)</b>
<u>Tools Needed</u> (B9) (B11)	With door still in the fully open position, place the front track shield (A7) over the designated holes on the outside of the wall angle assembly (A24) and horizontal track assembly (A6). Secure front track shield using four $\varnothing 6.35 \times 14.29\text{mm}$ (1/4" - 20 x 9/16") track bolts (A22) and $\varnothing 6.35$ (1/4" - 20) flange hex nuts (A30). Repeat for opposite side.
<b>STEP 21</b>	<b>Roller Stop</b> <b>(See Diagram 21 on pages 14 &amp; 15 of <i>Drawings of Installation, Use and Maintenance manual</i>)</b>
<u>Tools Needed</u> (B1) (B5) (B7) (B9) (B11) (B17) (B18)	<p><b>NOTE:</b> A roller stop (A25) is required for all 2134 mm (7' - 0") high doors or less, if a roller stop was included with your door, install it at this time. If your door was not supplied with a roller stop, skip this step.</p> <p><b>NOTE:</b> Roller stop can be installed on either the left or right low headroom horizontal track (A6).</p> <p>Raise door to a height that provides adequate opening clearance. Place locking pliers on both horizontal tracks just below the bottom rollers. This will prevent door from lowering. On the top horizontal low headroom track (2a), make a pencil mark (2y) on the flat portion of the track, showing the center line of the top roller. After having marked the top roller position on the top horizontal low headroom track, close the door. Measure 60 mm (2 3/8") (2z) towards the door opening from this pencil mark and make another, inside the top pencil mark inside the top horizontal low headroom track, on the underside of the flat portion of the track.</p> <p><b>NOTE:</b> When marking the hole location, be sure the mark is towards the door opening from the initial mark, showing the center line of the top roller (1z).</p> <p>Measure in 6mm (1/4") (3a) from the inside edge from the top horizontal low headroom track, at the point of the last pencil mark made. Make an intersecting mark at that point on the underside of the flat portion of the top horizontal low headroom track.</p> <p>Now center punch on the underside of the flat portion of the top horizontal low headroom track where the marks intersect. Drill a 7 mm (9/32") dia. hole through the flat portion of the top horizontal low headroom track. Once the hole has been drilled, remove any burrs from the drilled hole.</p> <p>Push the roller stop onto the flat portion of the top horizontal low headroom track, aligning the drilled hole in the track with the hole in the roller stop. The roller stop is now positioned on the underside of the flat portion on the inside of the top horizontal low headroom track.</p> <p><b>IMPORTANT! Accurately positioning the roller stop onto the horizontal low headroom track is critical. Once the roller stop is pushed onto the horizontal low headroom track, the tabs making contact with the steel surface, will make it difficult to reposition the roller stop.</b></p> <p>Secure the roller stop to the top horizontal low headroom track with a <math>\varnothing 6.35 \times 14.29\text{mm}</math> (1/4" - 20 x 9/16") track bolt (A22) and <math>\varnothing 6.35</math> (1/4" - 20) flanged hex nut (A30).</p> <p><b>NOTE:</b> <math>\varnothing 6.35</math> (1/4" - 20) flanged hex nut must be outside the track, to avoid possible interference with the top roller.</p>

<b>STEP 22</b>	<b>Step Plate / Lift Handle</b> (See Diagram 22 on page 15 of <i>Drawings of Installation, Use and Maintenance manual</i> )
<u>Tools Needed</u> (B1) (B3) (B7) (B10) (B18) (B20)	Locate the center of the bottom section (A1) and place a vertical mark (3b). Measure up from the bottom of the section 241 mm (9-1/2") and make a horizontal mark. Place the inside step plate (A14) flush against the section and center the top hole where the vertical and horizontal lines intersect. Align the bottom hole of the step plate with the vertical line. Mark the two hole locations (3c) and remove the step plate. Drill a 11mm (7/16") hole through the section at each mark and insert the outside step plate (A13). Align inside step plate holes and fasten from inside using (2) ø4.17 x 41.28mm (#8 x 1 5/8") phillips head screws (A32) provided.
<b>STEP 23</b>	<b>CE / Serial Number Label</b> (See Diagram 23 on page 16 of <i>Drawings of Installation, Use and Maintenance manual</i> )
<u>Tools Needed</u> NONE	When all steps of the installation are completed and door is ready for use, remove the strip covering the CE/ Serial number label (1v). This label is located on the end stile (1d) of the door's lock section (A2). The Limited Warranty is conditioned upon exact compliance with the Manufacturer's Notes of Installation, Use and Maintenance manual.
<b>STEP 24</b>	<b>Typical Door arm attachment</b> (See Diagram 24 on page 16 of <i>Drawings of Installation, Use and Maintenance manual</i> )
<u>Tools Needed</u> NONE	Align hole in the appropriate arm (3k) with holes in operator bracket (A27) tabs. Insert ø7.94 x 31.75mm (5/16" x 1 1/4") clevis pin (A35), making sure hole in clevis pin is outside of second tab of operator bracket. Insert hairpin cotter (A36) into clevis pin hole and spread hairpin cotter to ensure it will secure assembly.

## Operation (Use)

# IMPORTANT SAFETY INSTRUCTIONS



Attention - Risk of Injury:

1. READ AND FOLLOW ALL INSTRUCTIONS.
2. Always keep the moving door in sight and keep people and objects away until door is completely closed. NO ONE SHOULD CROSS THE PATH OF THE MOVING DOOR.
3. NEVER GO UNDER A STOPPED, PARTIALLY OPEN DOOR.
4. KEEP GARAGE DOORS PROPERLY BALANCED. See Notes of Installation, Use and Maintenance manual. An improperly balanced door increases the risk of severe injury. Have a qualified authorized door representative make repairs to cables, spring assemblies, and other hardware.
5. SAVE THESE INSTRUCTIONS.

When correctly installed, your door will be easy to use and operate smoothly. Always operate your door with controlled movements. Do not slam your door or throw your door into the open position, this may cause damage to the door or its components. If using the door with an automatic garage door opener, the door lock must be removed or made inoperable in the unlocked position, or an interlock switch must be installed. Pull ropes must be removed.

The following automatic garage door openers have been approved for these products:  
Marantec C220, Marantec C2sX / C2 Compact, Tormatic GTA 602, Sommer Duo 650 SL, Sommer Duo 500 S

**IMPORTANT!** If doors become electrically operated, they must be field tested to insure that they comply with EN-12453. Peak forces are to be measured at 50 mm and 300 mm from the garage door floor and the force can not exceed 400 N within a maximum period of time of .75 seconds.

## Service / Repair

TorqueMaster® springs are designed to provide service life of 10,000 cycles. Springs will need to be replaced in approximately 5 ½ years if you operate your door 5 times a day. Replace counterbalance cables and drums on doors over 3,66 m (12' - 0") wide, when replacing springs.

Door hardware (Hinges, Rollers, Counterbalance cables, Track etc.) are designed to provide service life of 40,000 cycles. To obtain a copy of the counterbalance cable tensile strength documentation, contact your local authorized dealer or manufacturer.

 Do not attempt to repair or service any damaged door yourself. For all service and repairs, contact a qualified authorized door service representative.

### TorqueMaster® Plus reset Instructions

(see Diagram C on page 16 of *Drawings of Installation, Use and Maintenance manual*)

 Read these instructions carefully before attempting to reset the TorqueMaster® system. If in question about any of the procedures, do not perform the work. Instead, have a qualified door service representative reset the system.

 Always keep moving door in sight and keep people and objects away until it is completely closed. To prevent possible severe injury, avoid standing in an open door way or walking through the doorway while the door is moving.

 Keep the garage door properly balanced. An improperly balanced door could cause severe injury. Have a qualified authorized door representative make adjustments / repairs to cables, spring assemblies, and other hardware.

This door is equipped with a TorqueMaster® Plus system, which provides a safety feature that prevents the door from rapidly descending in case of spring failure or forceful manual operation.

#### TYPICAL SIGNS OF AN ACTIVATED SYSTEM:

- a. Door opens, but will not close;
- b. Door makes a distinct "clicking" noise upon opening.

If the system is activated, carefully follow the reset instructions below along with the *Drawings of Installation, Use and Maintenance manual* to reset the TorqueMaster® plus system.

1. First, locate and visual inspect the TorqueMaster® plus end brackets to determine if the system has engaged or has not engaged, as shown. If system has engaged the drum pawl (3j) will make contact with cable drum (2m), as shown in Diagram [C.1] and [C.2]. If system has not engaged the drum pawl (3j) will not make contact with cable drum (2m), as shown in Diagram [C.3] and [C.4].

**NOTE:** The TorqueMaster® plus end brackets are located on top of the door on the right and left hand side.

2. Disengage opener (if installed) by pulling or placing emergency disconnect in the manual operated position.

If the system is activated, follow these steps to reset the system:

3. Clamp vice grips on both vertical tracks just below the bottom section.

4. Flip the pawl knob on both end brackets to the upper position (2q), as shown in Diagram [C.6].

5. With assistance, raise the door slightly to reset the system.

**IMPORTANT: BE PREPARED TO SUPPORT THE TOTAL WEIGHT OF THE DOOR.**

6. Cautiously remove the vice clamps from the vertical tracks; with assistance, lower the door.

**TorqueMaster® Plus reset Instructions -Continued**  
(see Diagram C on page 16 of *Drawings of Installation, Use and Maintenance manual*)

7. Check for spring tension. Starting on the right hand side, place a ratchet (B6) and 16 mm (5/8") socket (B14) onto the winding shaft (2f). Ensure ratchet is set so that it will tighten counter clockwise on the right hand side, and clockwise on the left hand side (if applicable). If tension is present, remove the ratchet and check the left hand side (if applicable). If spring(s) have tension, proceed to **STEP 8**; if no spring tension is present, contact a qualified door service representative to replace the spring(s).

**IMPORTANT: BE PREPARED TO HOLD THE FULL TENSION OF THE SPRING.**

**NOTE:** A 76 mm (3") extension (B13) is also recommended for added clearance from the wall angle.

8. Lift door and check its balance. Adjust spring(s), if door lifts by itself (hard to pull down) or if door is difficult to lift (easy to pull down). Anytime spring adjustments are made, pawl knob must be in the upper position (2q), as shown in Diagram [C.6].

An unbalanced door such as this can cause opener or TorqueMaster® operation problems. To adjust spring(s), only add or remove a maximum of 3/10 of a turn (three teeth of ratchet wheel) at a time. Both sides need to be adjusted equally on double spring doors. **NOTE:** Single spring applications require no spring winding on left hand side.

Clamp a pair of vice clamps on the vertical tracks just above the third roller on one side and just below the third roller on the other side. This will prevent the door from raising or lowering while adjusting the spring(s).

**IMPORTANT! Pawl knob must be in upper position (2q) to add / remove required number of spring turns, as shown in Diagram [C.6]. After adding / removing spring turns, pawl knob must be placed back in lower position (2s), as shown in Diagram [C.5].**

**Add spring Tension:** Place pawl knob in upper position (2q). The ratchet wheel is made of 10 teeth. To add spring tension, ensure the ratchet and socket is set so that it will tighten counter clockwise on the right hand side, and clockwise on the left hand side. Place the ratchet with 16 mm (5/8") socket onto the winding shaft, pull down to add 3/10 of a turn. Watch as three teeth of the ratchet wheel pass over the ratchet pawl, creating three "clicks".

**Remove spring Tension:** Place pawl knob in upper position (2q). To remove spring tension, ensure the ratchet and socket is set so that it will tighten counter clockwise on the right hand side and clockwise on the left hand side. It is recommended that a regular 16 mm (5/8") wrench be used. Place the wrench onto the winding shaft. Pull down on the wrench to relieve pressure between the pawl and the ratchet wheel. Push in on the pawl (3l) to allow the three ratchet wheel teeth to pass by the pawl, as you carefully allow the wrench to be rotated upward by the spring tension. Release the pawl (3l) to allow it to engage with the ratchet wheel.

Remove the vice clamps from the vertical tracks, re-check doors balance and adjust if necessary. When door is balanced and adjusted properly, place the pawl knobs (2s) in the active position (lower position), as shown in Diagram [C.5].

## Dismantle / Discard

To dismantle and discard the installed door, remove the door in the reverse order in which it was installed. See the installation section of this manual. Check local codes for proper discardment.

## Semi-Annual Maintenance

 Negligent or improper maintenance increases the risk of injury to persons and damage to property. A competent person should carry out the following maintenance procedures every six months.

 TorqueMaster<sup>®</sup> counterbalance system and cables are under extreme tension! Never tamper with the TorqueMaster<sup>®</sup> counterbalance system or serious injury may occur.

**Door cables:** Check door cables for signs of wear or fraying. If cables need replacing, contact a qualified authorized, door service representative.

**Spring tension:** To check spring tension: Open the door halfway. The springs should hold the door in this position. Should the door slide down or raise on its own, contact a qualified authorized door service representative to adjust the spring tension.

**Fixing points:** Check all fixing points, ensuring that they are firmly secured. Tighten any loose screws and/or bolts.

**Track rollers and door track:** The door should open and close smoothly. Ensure the door rollers are rotating freely when opening and closing the door. Should the rollers not turn easily or not turn at all: Clean the door track, removing dirt and any foreign substances. Clean and lubricate rollers inside of roller shields. Do not lubricate the door track.

**Cylinder lock:** Do not oil cylinder lock! If actuation is difficult, lubricate the lock with graphite dust.

## Maintenance / Painting Instructions For Pre-Painted Doors

### MAINTENANCE

While factory-applied finishes on steel garage doors are durable, it is desirable to clean them on a routine basis. Some discoloration of the finish may occur when a door has been exposed to dirt-laden atmosphere for a period of time. Slight chalking may also occur as a result of direct exposure to sunlight. Cleaning the door will generally restore the appearance of the finish. To maintain an aesthetically pleasing finish of the garage door, an annual washing of the door is recommended. A mild solution of detergent and water will aid in the removal of most dirt. The following solution mixture is recommended: One cup of Tide™, or other common detergents, which contain less than 0.5% phosphate, dissolved into five gallons of warm water.

**CAUTION:** NEVER MIX CLEANSERS OR DETERGENTS WITH BLEACH.

### SURFACE PREPARATION FOR PAINTING

Wax on the surface must be removed or paint peeling/flaking will result. To remove this wax, it will be necessary to lightly scuff the surface with a fine steel wool pad, saturated with soapy water (see Note No. 2). A final wipe and rinse should be done with clean water only, to remove any loose particles and any soapy film residue. Surface scratches, which have not exposed the metal substrate, can be lightly buffed or sanded with 0000 steel wool or No. 400 sand paper to create a smoother surface. Care must be taken to not expose the substrate under the paint (see Note No. 2). Once the substrate is exposed, the likelihood for rusting is greatly increased. If metal substrate is observed, the exposed substrate must be treated to prevent rust from forming (see Note No. 2). Sand the exposed area lightly and paint with a high quality metal primer, specifically intended for galvanized surfaces, to protect the area from corrosion. Follow drying time on primer can label before applying topcoat. It is advisable to test in an inconspicuous area, to evaluate adhesion. If poor adhesion is observed, surface preparation for painting the factory - applied finish, must be repeated until desired results are achieved. Again, care must be taken to not expose the substrate under the paint.

### PAINTING

After the surface has been properly prepared it must be allowed to dry thoroughly, then coated immediately with a premium quality latex house paint. Follow the paint label directions explicitly. Oil base, or solvent base paints are not recommended. Please note that if substrate is exposed and not properly primed, painting with latex paint may cause accelerated rusting of the steel in the exposed area.

### NOTES:

1. Repainting of finish painted steel doors cannot be warranted, as this condition is totally beyond the door manufacturer's control.
2. If the finish painted steel door surface has a textured surface representing wood grain, stucco, etc., this step should not be attempted as danger of exposing substrate is greatly increased.
3. Consult a professional coatings contractor if in doubt about any of the above directions.
4. Follow directions explicitly on the paint container labels for proper applications of coatings and disposal of containers. Pay particular attention to acceptable weather and temperature conditions in which to paint.

### DÉCOR LITES ACRYLIC GLAZING CLEANING INSTRUCTIONS:

1. Clean acrylic glazing with nonabrasive soap or detergent and plenty of water. Use your bare hands to feel and dislodge any caked on particles. A soft, grit-free cloth, sponge or chamois may be used to wipe the surface. Do not use hard or rough cloths that will scratch the acrylic glazing. Dry glazing with a clean damp chamois.
2. Kerosene may be used to remove grease and oil. When using kerosene for cleaning purposes, make sure that you are familiar with its properties, using it only in a well ventilated area away from any sources of sparks and/or fire.
3. DO NOT USE: Window cleaning fluids, scouring compounds, gritty cloths, gasoline, or solvents such as alcohol, acetone, carbon tetrachloride, etc.

# Replacement

TorqueMaster® springs are designed to provide service life of 10,000 cycles. Springs will need to be replaced in approximately 5 ½ years if you operate your door 5 times a day. Door seals are designed to provide a longer service life. If these components do need to be replaced, follow the instructions on pages 15 - 16.

## Spring Replacement

(See Diagram D on pages 17 - 18 of *Drawings of Installation, Use and Maintenance manual*)

**IMPORTANT! Right and left hand is always determined from inside the building looking out.**

 Counterbalance spring tension must be relieved before removing any hardware. A powerful spring releasing its energy suddenly can cause severe injury.

Remove the drum wraps (A18) from cable drums (2m) (if installed) by twisting the drum wrap while pulling it away from the drum. Starting with the right hand side, ensure ratchet pawl knob (2q) is in upper position. Place a ratchet (B6) with a 16 mm (5/8") socket (B14) on the winding shaft (2f). **NOTE: A 76 mm (3") extension (B13) is also recommended for added clearance from the horizontal angle.** To remove spring tension, ensure the ratchet and socket is set so that it will add tension (counter clockwise) on the right hand side and (clockwise) on the left hand side. Rotate ratchet to relieve pressure between the pawl and the ratchet wheel. Push in on the pawl (1e) to allow the ratchet wheel teeth to pass by.

**NOTE:** In the event of a broken spring, it might not be necessary to unwind that spring(s).

 Be prepared to hold the full tension of the spring

Gently let the ratchet rotate upward, while watching the number of teeth on the ratchet wheel pass by the pawl. Remove 3/10 of a turn (watch the 3 teeth of the ratchet wheel pass the pawl). Release the pawl (1e) to allow it to engage with the ratchet wheel. Repeat this process until all spring tension has been removed in both springs. Cables should be loose and the torque tube should be free to rotate in either direction.

 Spring(s) are fully unwound when counterbalance cables have no tension.

 Do not use an impact gun to unwind the springs.

Starting with the right hand end bracket, first remove the  $\varnothing 7.94 \times 19.05\text{mm}$  (5/16" - 18 x 3/4") carriage bolt (A33) and one  $\varnothing 7.94$  (5/16" - 18) hex nut (A34), then remove the ~~two~~  $\varnothing 6.35 \times 15.88\text{mm}$  (1/4" - 14 x 5/8") self tapping screws (A26) from the end bracket (A20). Holding the end bracket with a pair of locking pliers (B15), carefully pry the end bracket from the front support bracket (A5) and winding shaft with a flat head screwdriver (B9). Repeat for left hand end bracket (A19).

Bend the center bracket tab (2d) over. Lift one end of the TorqueMaster® tube (A16) and slide the cable drum off. Realign the groove (2h) in the winding shaft with the round notch (2i) in the front support bracket and drape the counterbalance cable with drum (A17) over the front support bracket. Repeat for the other side. Remove TorqueMaster® tube and gently lay it on the floor. Remove the left (3g) hand and right (3f) hand springs from the torque tube.

**NOTE:** Single spring application will have no spring on the left hand side (3g), only a loose winding shaft.

**NOTE:** The cable drums and springs may be difficult to remove. If so, twist the cable drum and TorqueMaster® tube to aid removal.

## Reinstallation of TorqueMaster® Single and Double Springs

Slide the spring(s), perch (3h) end first, into the torque tube (each spring is identified as to right and left hand, on the perch).

**NOTE:** Prior to re-installing the TorqueMaster® tube, ensure the drum wraps are on the TorqueMaster® tube as outlined in **STEP 13**. Lift the torque tube assembly up and align the center bushing (1t) into the center bracket (2k). Check TorqueMaster® tube for level and adjust if necessary. Bend the center bracket tab back over the center bushing. Complete **STEPS 14, 15, 17 AND 18** (cable drums, end brackets, adjusting cables and winding springs) in this manual. Replace drum wraps if removed. Remove locking pliers and check door balance and adjust if necessary.

## Header Seal Replacement

(See Diagram E on page 18 of *Drawings of Installation, Use and Maintenance manual*)

Open door fully. Clamp locking pliers (B15) onto both vertical tracks just below bottom roller to prevent door from falling while removing the header seal (A8).



Failure to clamp track can allow door to fall, possibly causing severe injury.

To replace the header seal, remove the lag screws (A29) over the entire length of the header seal. To install a new header seal, refer to **Step 6 on page 6** of this manual.

## Vertical Seal Replacement

(See Diagram F on page 18 of *Drawings of Installation, Use and Maintenance manual*)

To replace the vertical seal (A9), open door fully. Using a 11 mm (7/16") wrench (B11), loosen the lags (A29) (recommend 3 full turns) over the entire length of the wall angle assembly (A24).



To prevent possibly severe injury, DO NOT remove lag screws completely.

Pry the wall angle assembly away from door jamb (1p), allowing vertical seal to be pulled from the wall angle (A24). Repeat for opposite side.

To attach a new vertical seal, measure and cut the vertical seal to your door opening height plus 25 mm (1"). Align the profiles of the vertical seal and wall angle. Starting at the bottom of the door, press the vertical seal on over the whole length of the wall angle assembly. With the vertical seal in place, tighten all the lag screws over the entire length of the wall angle assembly.

## Astragal Replacement

(See Diagram G on page 19 of *Drawings of Installation, Use and Maintenance manual*)

With the door in the fully closed position, remove the four  $\varnothing 6.35 \times 14.29\text{mm}$  (1/4" - 20 x 9/16") track bolts (A22) and  $\varnothing 6.35$  (1/4" - 20) flange hex nuts (A30) from the front track shield (A7) on either side.

Open door fully, making sure the astragal (1m) is accessible between upper and lower horizontal track. Place two locking pliers (B15) on the horizontal track, one in front of the top bracket roller and one behind the top bracket roller.



Failure to clamp track can allow door to fall, possibly causing severe injury.

On one side, pry the corner of the astragal retainer (3i) open using a flat head screwdriver (B9). Pull down firmly on astragal, removing it completely from the astragal retainer. Next, pry open the opposite end of the retainer with a flat head screwdriver, allowing new astragal to slide past dimple in retainer.

With assistance, hold the astragal straight and aligned with the retainer, slide astragal through entire length of the retainer until astragal is even with opposite end of the retainer. Be careful not to stretch astragal.

Verify that astragal does not protrude more than 13 mm (1/2") past the ends of bottom section (A1). Trim off any excess. With the astragal in place, re-crimp the astragal retainer using a flat head screwdriver and hammer (B16) to prevent astragal from sliding. Reinstall the front track shield with the four track bolts and nuts removed. Remove the two locking pliers that are holding the door in place.



As a safety feature, both right hand and left hand front shield plates must be installed to avoid serious injury to fingers or hands. Never place fingers or hands into space between door sections and horizontal track when operating door.

## Models: Wayne-Dalton Prestige + / 40 mm / 9500

# LIMITED WARRANTY

1. This Limited Warranty is extended by Wayne-Dalton Corp. In Lieu Of any other warranties, express or implied, including any implied warranty of MERCHANTABILITY.
2. The Manufacturer (Wayne-Dalton Corp.) warrants the models 9500 and 40mm™ steel garage door sections for a period of **ten (10) years** from the time of installation against deterioration such as cracking, splitting or rust-through.
3. The Manufacturer warrants the garage door hardware, track, and springs for the above referenced models steel garage doors for a period of **two (2) years** from the time of installation against defects in material or workmanship.
4. The above conditions apply, provided that the above referenced 9500 and 40mm™ steel door is properly installed, used, and maintained in accordance with the instructions provided by the Manufacturer under normal residential use and service.
5. This limited warranty extends only to the original purchaser, providing the door is installed in his/her place of primary residence. This limited warranty is not transferable. This limited warranty applies to residential property only and is not valid on commercial or rental property.
6. This limited warranty covers a consumer product as defined by Directive 1999/44/EC of the European Parliament and of the Council of 25 May 1999 (herein referred to as the Directive) on certain aspects of the sale of consumer goods and associated guarantees. No warranties, expressed or implied, shall extend beyond the applicable time periods as set forth above. The above warranties and warranty language shall also not operate to extend any rights granted by the above referenced Directive or any applicable Member State provision of national law beyond the dates specified in said Directive or provision of national law.
7. The Manufacturer shall, upon notification, correct covered product defect(s) by repairing or replacing any defective product(s). The charges that will be covered include those as listed in the Directive.
8. No employee, distributor, or other representative is authorized to change the foregoing limited warranty in any way or grant any other warranty on behalf of the Manufacturer.
9. The Manufacturer shall not be responsible for damage resulting to or caused by its products by reason of improper storage, improper installation, unauthorized service, alteration of products, neglect, abuse, or attempt to use the products for other than the customary usage or intended purposes. This limited warranty is null and void if the above referenced models of steel garage doors are punctured with any hole or if a hole is drilled into the door sections other than those specified in the Notes of Installation, Use and Maintenance.
10. Claims for defects in material and workmanship covered by this limited warranty shall be made in writing, within the warranty period, to the distributor from whom the product was purchased. The Manufacturer may either send a service representative or have the product returned to the Manufacturer for inspection. If judged by the Manufacturer to be defective in material or workmanship, the product will be replaced or repaired at the option of the Manufacturer, free from charges as described in the Directive.
11. The remedies of the purchaser set forth herein with respect to the express limited warranties referenced herein are **exclusive and are in lieu of all other remedies**. The liability of the Manufacturer, whether in contract, or tort, or pursuant to any other types of liability under the applicable system of law, or under any limited warranty or otherwise, shall not extend beyond its obligation to repair or replace, at its option, any product or part found by Manufacturer to be defective in material or workmanship. Manufacturer shall not be responsible for any direct, indirect, special, or consequential damages of any kind or nature.
12. The legal rights which you, the purchaser, are granted under applicable national legislation governing the sale of consumer goods are not affected by this limited warranty.
13. The sale of this product shall not be subject to the terms of International Treaty for the Sale of Goods.
14. This limited warranty is conditioned upon exact compliance with the Manufacturer's Notes of Installation, Use and Maintenance which accompany the above referenced Models 9500 and 40mm™ garage door.
15. Contact information:

	Wayne-Dalton Europe Customer Service Department 1 Rue Maurice Hollande 51100 Reims France	Wayne-Dalton Corp. US Customer Service Department P.O. Box 67 Mt. Hope, OH 44660
	<a href="http://www.waynedaltoneurope.com">www.waynedaltoneurope.com</a>	<a href="http://www.wayne-dalton.com">www.wayne-dalton.com</a>

