

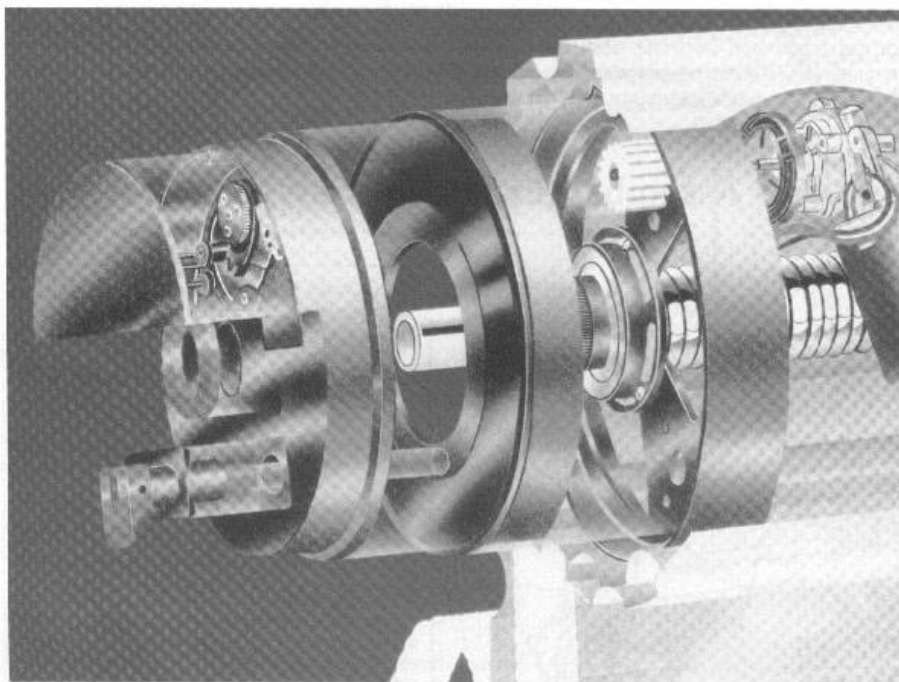

**Glidermatic GRD™
Roller Door Automatic Operator**



**Installation Instructions and
GRD Owners Manual**

Glidermatic GRD™ Roller Door Automatic Operator

IMPORTANT SAFETY INFORMATION - PLEASE READ CAREFULLY

SAFETY INSTRUCTIONS

WARNING! :-To reduce the risk of severe injury or death

- Never let children operate or play with the doors controls.
- Keep the remote control away from children.
- Always keep the moving door in sight and away from people and objects until it is completely closed. **NO ONE SHOULD CROSS A MOVING DOOR.**
- Do not disengage the door opener to manual operation with children / persons or any other object including motor vehicles within the doorway.
- The Garage door must be well balanced. Sticking or binding doors can falsely trigger the obstruction sensing of the Glidermatic Unit.
- **All maintenance should be carried out by suitably qualified personnel.**
- Test the door opener monthly. The garage door **MUST** reverse on contact with a 5 to 10 CM high object on the floor. The amount of force the door should encounter is adjustable. Failure to adjust the opener properly may cause severe injury or death.
- The GRD Operator has a patented electronic obstruction system that provides **safe** and reliable operation. It is however a legal requirement in some countries to also install a Photo-electric sensor across the door way, please check this requirement with your local distributor.

Glidermatic® Drive Assembly (Exploded View)

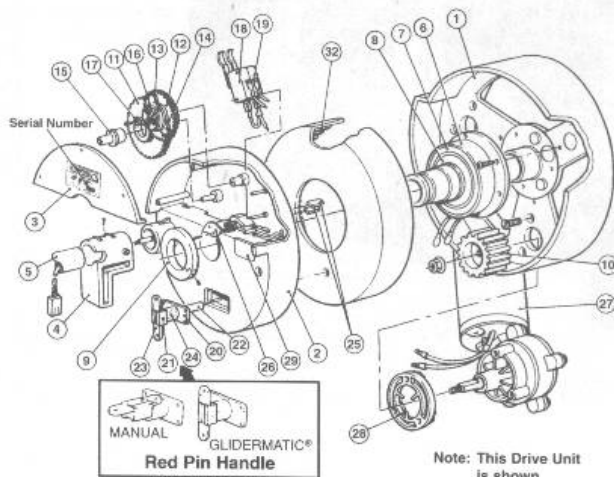

Fig. 1

| | | | | | |
|----|-------------------|---|----|---------------------|---|
| 1 | Drum Wheel | 1 | 16 | Keeper Plate | 1 |
| 2 | Main Body | 1 | 17 | Retain Washer | 2 |
| 3 | Main Body Lid | 1 | 18 | Limit Switch 'Up' | 1 |
| 4 | Anchor Block | 1 | 19 | Limit Switch 'Down' | 1 |
| 5 | Anchor Tube | 1 | 20 | Pin Holder | 1 |
| 6 | Slip Ring Brush | 1 | 21 | Pivot Pin | 1 |
| 7 | Slip Ring - Outer | 1 | 22 | Pin | 1 |
| 8 | Slip Ring - Inner | 1 | 23 | Red Pin Handle | 1 |
| 9 | Split Ring | 1 | 24 | Pin Spring | 1 |
| 10 | Main Gear Drive | 1 | 25 | Contact Brush | 2 |
| 11 | Idler Gear | 1 | 26 | Brush Cover | 1 |
| 12 | Cam Gear | 1 | 27 | Geared Motor | 1 |
| 13 | Cam 'Up' | 1 | 28 | Motor Spacer | 1 |
| 14 | Cam 'Down' | 1 | 29 | Blanking Cover | 1 |
| 15 | Spacer Brush | 1 | 32 | Main Gear | 1 |

Installation Instructions

These instructions are to be read in conjunction with Gliderol Roller Door installation instructions.

Please note:-

THE FOLLOWING INSTRUCTIONS FOR FIXING OF THE DRIVE UNIT ASSEMBLY TO THE DOOR ARE FOR A RIGHT HAND INSTALLATION. (Refer to Fig 1-8).

- Check the door U bolt is securely tightened on the LEFT hand side of door
- Raise the door and tie a rope around the centre to secure the roll
- Support the right hand end of the door with a suitable prop, e.g. step ladder and soft padding to protect the door surface (Fig. 2)

STOP WARNING:- DO NOT ALLOW CHILDREN/PERSONS AROUND THE DOOR WHEN PROPPED. SERIOUS PERSONAL INJURY AND/OR PROPERTY DAMAGE CAN RESULT FROM FAILURE TO FOLLOW THIS WARNING.

- Carefully loosen and remove the right hand axle U bolt.
- Make sure the door supporting prop is secure. While the door is supported remove the right hand wall mount bracket. (Fig. 3)
- Remove the geared motor (27) and motor spacer (28) from the packaging material. Align the spacer over the three motor mounting holes and insert the motor assembly between the spoke sections of the drum wheel. Align the assembly with the three counter sunk holes in the spoke section, Affix with screws supplied 3 X (6x25mm counter sunk) using an appropriate flat bladed screwdriver. (Ensure the motor assembly is securely fixed to the drum wheel before proceeding)
- Remove the motor shaft screw and slide on the main drive gear (10), refit the shaft screw and tighten.
- Slide the Slip Ring assembly (6,7,8) over the door axle, locate into a position where the two Slip Ring wires are closest to the motor. Connect the two wires from the Slip Ring assembly to the motor leads. Observe the polarity of the four wires i.e. red to red black to black.
- Three boss mounts on the drum wheel will locate the Slip Ring assembly. Using the three self tapping screws provided securely fix into position (8 5/3).
- Slide the Main Ring Gear (32) over the door axle and engage teeth with the motor drive gear.
- Slide main body (2) over door axle, make sure the manual release pin (23) is in manual position. locate contact brushes (25) into inner and outer slip ring (7,8)
- The Main Body should now be sitting flush up against the Ring Gear. Attach Split Ring (9) to Slip Ring extrusion and secure split ring self tapping screw. (6 3/8)
- Replace right hand side wall mount bracket (Fig. 4)
- Remove support from door and rest axle carefully on wall mounting bracket.

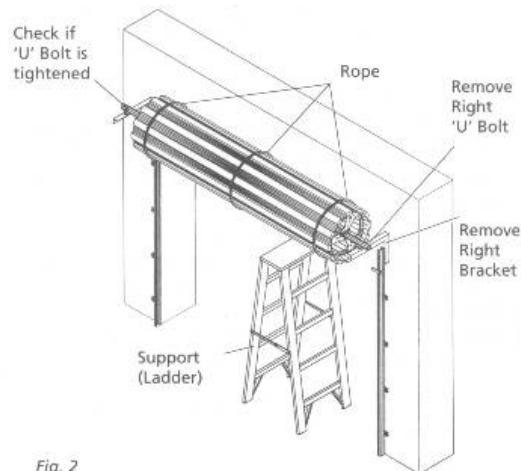

Fig. 2

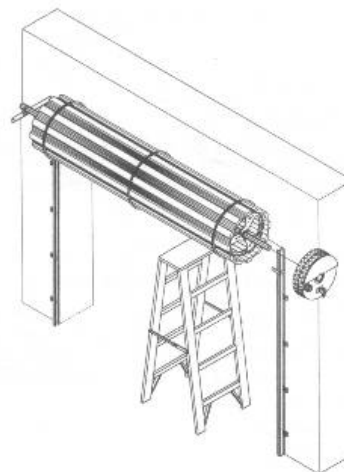

Fig. 3

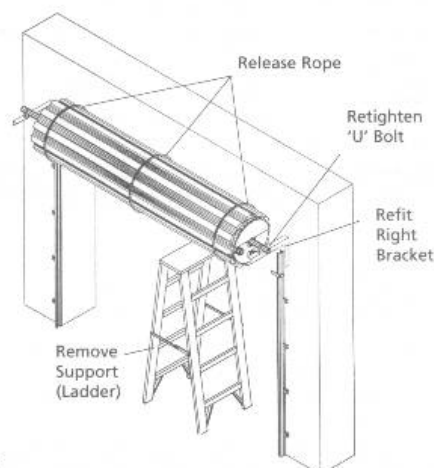

Fig. 4

Installation Instructions

- o) Slide anti coning collar over spindle so that it is flush with edge of the split ring. Secure anti coning tightly to ensure it will not move. (Fig. 5)
- p) Push the anchor tubes through the anchor block and slide the assembly over the wall bracket. Thread the drive unit loom through the anchor tube and locate the anchor tube firmly into the female boss on the main body. Once in place lock the anchor tube and block with the self tapping screw provided. (6 3/8) (Fig. 5)
- q) Realign door and securely re-affix U bolt
- r) Place the weight bar provided on the bottom rail. Secure the weight bar with the two spring clips provided 300mm from each end of the weight bar. (Fig. 6)
- s) Remove the control box from the packaging material, separate the control box lid from the base by releasing the snap fit catch.
- t) Affix control box base securely to the garage wall at approximately head height. Connect drive unit loom to control box and activate power.

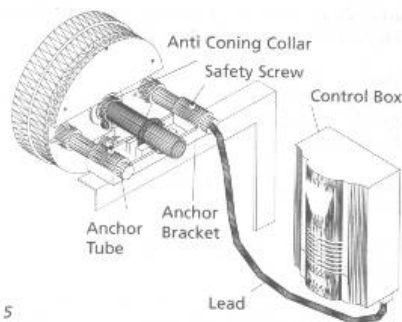

Fig. 5

u) Setting the limits

The two cams shown (Fig. 7) set the length of door travel during automatic operation. **Ensure manual release pin is in manual** (Fig. 7) and that door moves freely in manual operation.

Adjustment:-

Loosen the three locking screws within the cam assembly to enable manual rotation of the cams.

Inner Cam (14):-

This cam will rotate in the clockwise direction during the downward travel. Adjustment is made so that when the door is fully closed the cam has just activated the bottom limit switch.

Outer Cam (13):-

This cam will rotate anti-clockwise during the upward travel. Adjustment is made so that the cam activates the top limit switch when the door has reached the desired height.

CAUTION: The up cam should be set to stop the roller door just below the guide stop to avoid jarring the drive gears etc. Operate the control box push button several times to ensure that the limit switches operate satisfactorily. Tightly secure the cam retaining screws.

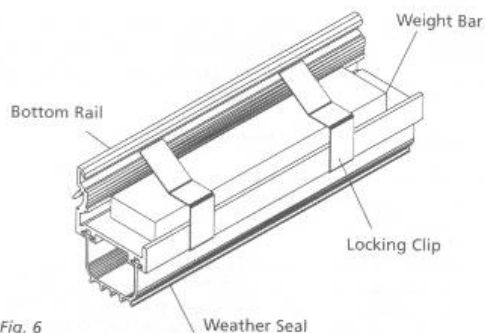

Fig. 6

- v) Engage Glidermatic by switching manual release pin to automatic refer (Fig. 1).

Move door manually until you hear pin engage.

Activate Glidermatic by pressing push button on control box.

Glidermatic operator should engage roller door and door travel should be downwards. If "down" (14) cam has been set correctly, door should stop at floor level. Activate Glidermatic - door should travel upwards and stop at desired height if "up" (13) cam is set correctly, door should travel upwards and stop at desired height if "up" (13) cam is set correctly.

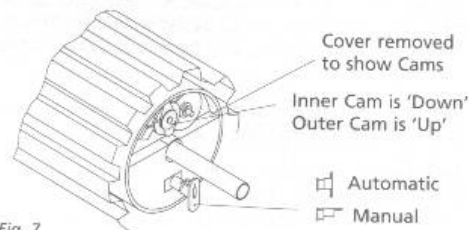

Fig. 7

If door does not stop at desired positions turn off power and go back and readjust cams, as detailed above, (Setting the Limits).

- w) Final Security - Fully close the door, mark the corrugation just before the Curtain leaves the top roll, drill through the Curtain and the Drum wheel rim and apply a 'pop rivet' or self tapping screw. This must be done at both ends of the door (Fig. 8).

NOTE: After marking the flute the Curtain may be raised to give access for drilling etc.

WARNING: Care must be exercised when drilling to avoid internal wiring.

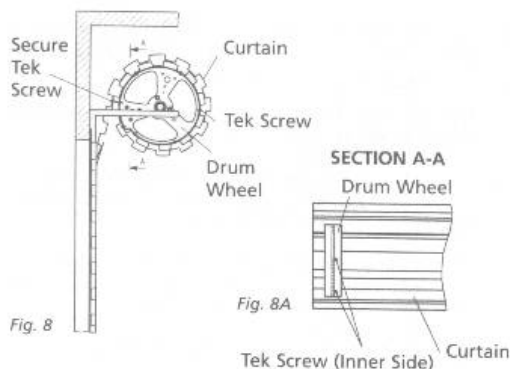

Fig. 8

IMPORTANT: Security rivet/tek screw must always be applied to inner side of drum wheel as shown in Fig. 8A. Failure to do so may result in internal damage to the Glidermatic drive unit.

Congratulations you have now successfully retrofitted your Glidermatic drive unit. Please proceed to Control Box Set Up.

Installation Instructions

Control Box Set Up (Fig. 9)

- Adjust the Obstruction Detection Pot (4) to Maximum (Fully clockwise)
- Open or close the door with the operation switch (6). Whilst the door is travelling turn the obstruction sensitivity pot slowly anti-clockwise until an overload condition occurs ie door going up stops before reaching the set top limit or door going down auto-reverses before reaching set bottom limit.
- Now adjust the pot 10 degrees in the **clockwise direction**.
- Cycle the door a few times ensuring an overload condition is not registered during normal operation. If an overload condition is registered re adjust the pot a further 10 degrees in the **clockwise direction**.

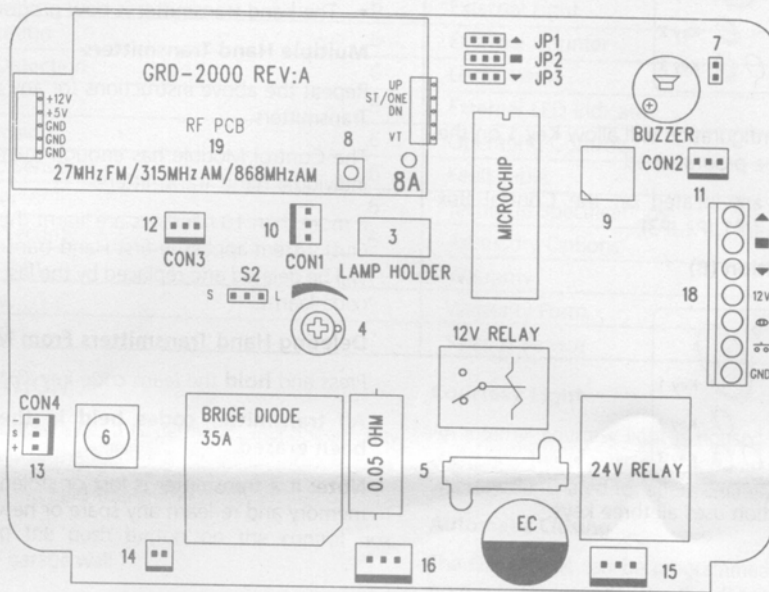



Fig. 9

* S2 jumper :

Only 1 "0.05ohm 5 watt resistor" will be installed.

For all residential doors, S2 jumper should be in the position of S  L

For all commercial doors, S2 jumper should be in the position of S  L

(Note : Must be used in conjunction with Photocell option.)

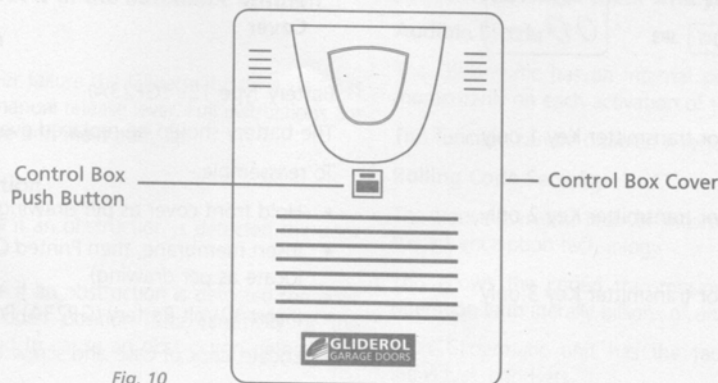

Fig. 10

Installation Instructions

Transmitter Key and Code Setting Refer to Fig. 9

Key Setting

Choose the Transmitter key configuration (JP1/JP2/JP3) from the following :-

Single door installation (A)

Key 1

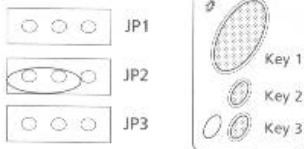

The above jumper configuration will allow Key 1 on the hand transmitter to be programmed.

Note: The jumpers are located on the Control Box Printed Circuit Board. (JP1,JP2,JP3).

Single door installation (B)

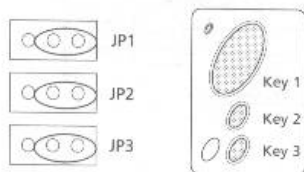

This above configuration uses all three keys.

- ▲ Up Key 2
- Stop Key 1
- ▼ Down Key 3

Two or Three door installation

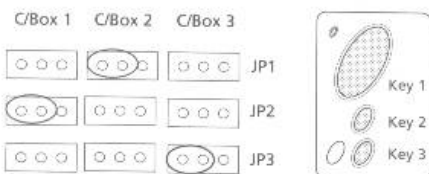

Door 1

Jumper configuration for transmitter Key 1 only

Door 2

Jumper configuration for transmitter Key 2 only

Door 3

Jumper configuration for transmitter Key 3 only

Code Setting

Once the Key configuration is set you can now program in the security code from your hand transmitter (s)

- Press the learn code key once (8)
- Learn LED Indicator will light (8A)
- Press the hand transmitter Key that will operate the door eg: for single door installation (A) you would press Key 1
- Learn LED (8A) will go out
- The hand transmitter is now programmed

Multiple Hand Transmitters

Repeat the above instructions for any subsequent Hand Transmitters.

The Control Module has enough memory for up to 10 individual Hand Transmitters.

If more than 10 handsets are learnt the FIFO (First In First Out) system applies ie first Hand transmitter code learnt will be deleted and replaced by the last Hand Transmitter code learnt.

Deleting Hand Transmitters From Memory

Press and **hold** the learn code key (8)* for 5 seconds.

All transmitter codes held in the memory have been erased.

Note: If a transmitter is lost or stolen please erase the memory and re-learn any spare or new transmitters.

Key Ring Transmitter



Inside of Front Cover



PCB



Back

Battery Type 12V (GP23A)

The battery should be replaced every 12 months

To reassemble:-

- Hold front cover as per drawing
- Insert membrane, then Printed Circuit Board (This will locate as per drawing)
- Insert 12Volt Battery (GP23A) Positive towards screw
- Locate back of case and screw together

Owner's Manual for the Glidermatic GRD™ Roller Door Automatic Operator

CONGRATULATIONS! on the purchase of your Glidermatic Door Opener

The Glidermatic Roller Door has been granted the Industrial Design Council of Australia Award. This award reflects Gliderol Internationals commitment to continued advancement in technology and the use of the highest quality components and materials. This ensures a highly reliable and quality assured product that should give years of trouble free service.

INDEX

| | Page | | Page |
|-----------------------|------|--------------------------|------|
| Door Operation | 6 | External Light | 7 |
| Manual Operation | 6 | External Counter | 7 |
| Obstruction Detection | 6 | Local Alarm | 7 |
| Courtesy Light | 6 | External LED Indicator | 7 |
| Automatic Closing | 6 | Operating Controls | 7 |
| Photo-electric Sensor | 6 | Fault Table | 8 |
| Audible Buzzer | 6 | Technical Specifications | 9 |
| Rolling Code Security | 6 | Accessory Options | 9 |
| Key Ring Handset | 7 | Warranty | 10 |
| Alarm Closure | 7 | Warranty Form | 11 |
| Remote Switch | 7 | Sales & Service | 11 |

DOOR OPERATION

A roller door equipped with a Glidermatic GRD opener may be operated by any of the following three methods:-

- by using the hand held Transmitter
- by depressing the push button on the control box. (mounted on the garage wall)
- by an alternative bell press button, remotely hard wired.

Momentary activation of either of the above methods will activate the door to open or close.

The door can be stopped at any point during travel by a second activation of (a,b, or c) The following activation will move the door in the opposite direction.

! WARNING

- Ensure that the Centre Lift Lock is not engaged when the Drive Unit is in the automatic position.

Manual Operation

In the case of a power failure the Glidermatic drive unit has an easily accessible manual release lever. Full instructions are illustrated on the drive unit main body lid.

Obstruction Detection

During an open cycle if an obstruction is detected the door will stop.

During a closing cycle if an obstruction is detected the door will reverse to the open position. The sensitivity or the amount force required to cause an obstruction detection is fully adjustable.

Courtesy Light

An internal courtesy light is housed within the control box enclosure. This is activated during an open or close cycle and will stay illuminated for approximately 60 seconds.

Automatic Closing

The Glidermatic can be programmed to automatically close from 5 to 60 seconds after the door has been opened.

Photo-electric sensor

The Glidermatic Operator includes an interface for the connection of a photo-beam sensor.

The Photo-beam sensor can be supplied as an accessory option

!WARNING

In some countries it is a legal requirement to fit Photo-cell sensors. Please check with your local distributor.

Audible Buzzer

The Glidermatic has an internal piezo siren that will beep momentarily on each activation of the door.

This function can be disabled if required.

Rolling Code Security

The transmitter and receiver incorporate the latest state of the art encryption technology.

This allows the coded transmission to change after each operation with literally billions of unique combinations.

Each Glidermatic unit has the facility to store up to 10 individual handsets.

Key Ring Handset

The hand transmitter is manufactured using the latest surface mount technology and incorporates 3 functional buttons. This enables the user to remotely control up to 3 separate operators from the one handset. The soft touch silicon buttons have been impregnated with a "night glow" material for easier visibility.

Alarm Closure

If an attempt is made to force open the door from a closed position. The Glidermatic Controller will Pulse operate the door to the fully closed position.

Remote switch

A simple Bell Press type momentary switch can be hard wired directly to the control board.

ACCESSORY OPTIONS

With the installation of a small accessory board the Glidermatic Controller can perform the following functions:-

External Light

This accessory option will allow the connection of auxiliary lighting ie drive way lighting, internal garage lights.

NB: Max. Load 100W

!WARNING All mains lighting must be fitted by a qualified Electrician / Personnel

External Counter

For commercial applications an electronic counter (for door operations) can be used for warranty verification.

Local Alarm

A Piezo Alarm Siren can be fitted as a local intruder alert. This will be activated if an attempt is made to force open the door from the fully closed position. In conjunction the door will perform an Alarm Closure *.

This output can also be wired into an existing home alarm system.

* Alarm closure as above.

External LED Indicator.

An LED panel is fitted within the house (hard wired) to show the status of the door ie open or closed.

OPERATING CONTROLS (Fig. 9)

1) Control Box Push Button

Pressing this button will open, close or stop the door.

2) Hand transmitter

Nominally for a single door installation only the large elliptical button is programmed to operate the door, a momentary press of this button will open , close, or stop the door.

Note: The standard Glidermatic handset has **three** fully functional and independent buttons. This allows the handset to operate up to three openers in the Gliderol series ie Roller Door Opener, (GRD) Tilt and Sectional Opener, (GTS) and the Commandoor 2 Gate Opener.

INTERNAL CONTROLS / CONNECTIONS

3) Courtesy Lamp

This is a 9 Watt 24VDC Globe which is turned on after each activation of the Control Box. The illumination period is approximately 60 seconds.

4) Obstruction Detection (overload)

This adjustment pot allows you to increase or decrease the amount force required on a moving door to register an overload condition.

5) Fuse

This is an automotive blade type fuse.

15A (Blue)

6) Operation Switch (During Set Up Only)

This PCB mounted switch will allow you to operate the controller whilst the front cover has been removed, enabling you to complete the set up adjustments and test the unit.

7) Internal Piezo Buzzer (enable/disable)

The Piezo Buzzer is factory set in the enabled mode. To disable remove the jumper pin (as shown in diagram 9)

8) Code Learning

This button is used to store and delete transmitter(s) from the on board memory.

The memory will allow up to a maximum of 10 handsets to be recorded.

If more than 10 handsets are learnt the FIFO (First In First Out) system applies ie first code learnt will be deleted and replaced by the latest code learnt.

8a) Learn LED Indicator

9) Automatic Close

0 Position Auto - Close disabled.

1 Auto Close enabled 5 sec. delay

2 Auto Close enabled 15 sec. delay

3 Auto Close enabled 20 sec. delay

4 Auto Close enabled 30 sec. delay

5 Auto Close enabled 40 sec. delay

6 Auto Close enabled 50 sec. delay

7 Auto Close enabled 60 sec. delay

Please Note :

Time delay will start once the door has fully opened

Operating Controls *(continued)*

10) Con 1

External Light Accessory Board connection

11) Con 2

External Alarm/Siren Accessory Board connection

12) Con 3

External LED Status Indicator Accessory Board connection

13) Con 4

Front Cover Push Button Connection

14) J5

External counter connection

15) J1

Motor loom connection

16) J4

Transformer Connection (24VAC C/T)

17) JP1 / JP2 / JP3

Transmitter button configuration (set up)

18) U9

Remote switch connection / Photocell connection

▲ Up Direction

■ Stop

▼ Down Direction

12V 12V DC

⊙ Photocell

↓↑ UP, DOWN, STOP

GND Ground

19) Radio Receiver

This receiver is factory preset and has no user adjustment.

Please **DO NOT** adjust any the tuning caps.

Before you call your local Gliderol agent please check the following Fault Table

| SYMPTOM | ACTION |
|---|--|
| 1. Door does not operate | → Check electrical supply to unit. → Press hand set and/or bell press button again. |
| 2. Drive motor operates but door does not move. | → Check Red Pin Handle is in horizontal position and engaged in drive (move door manually to re-engage). |
| 3. Drive motor operates when red Pin Handle is engaged but door does not move. | → Pin is broken and requires replacing. Check by attempting the move door manually when the motor has stopped running. |
| 4. Door auto-reverses after closing fully. | → Check setting of cams relative to the lower limit switch - unit must stop using the limit switch NOT by striking ground. |
| 5. Door stalls at fully open position and continues to try to open the door if button is pressed again. | → Check setting of cams relative to the upper limit switch - unit must stop using the limit switch NOT by striking the guide top stop. |
| 6. Door open and closed positions incorrect (Stop short) | → Adjust cams relative to the limit switches until required positions are achieved. |
| 7. Courtesy light comes on but door does not move. | → Check that the Drive Unit is plugged in and motor operates. → Check that the Red Pin Handle is engaged. |
| 8. Hand set range diminishes. | → Replace hand set battery after 12 months. → Check position of antenna on unit to ensure it is relatively straight and not adjacent to the power cord. |
| 9. Hand set does not open door. | → Replace hand set battery after 6 - 12 months. → Check position of antenna on unit to ensure it is relatively straight and not adjacent to the power cord → Check that the hand set has been programmed for the door. |
| 10. Door auto-reverses before it is closed. | → Check the sensitivity setting on the circuit board. → Check the door is not jammed in tracks. |
| 11. Door stops during opening. | → Check the sensitivity setting on the circuit board. → Check the door is not jammed in tracks |
| 12. Door does not operate and the courtesy lamp is not on. | → Check power is switched on. → Check fuse on circuit board and replace. → Check the door is not jammed in tracks. |

Technical Specifications

| CHARACTERISTICS | SYMBOL | MIN. | TYP. | MAX. | UNIT |
|----------------------------|---------|-------|------|-------|-------|
| Input Voltage | | 218 | 240 | 262 | VAC |
| System Power Dissipation | | | 125 | | W |
| Transformer Power | | | 125 | | VA |
| Transformer Output Voltage | J4 | 21.6 | 24 | 26.4 | VAC |
| Work Voltage of Motor | J1 | 18 | 24 | 34 | VDC |
| Lamp Power | LP1 | | 8 | 10 | W/DC2 |
| Buzzer Voltage | BZ1 | | 12 | | VDC |
| Fuse | F1 | | 15A | | A |
| Carrier Frequency Range | Handset | 314.9 | 315 | 315.1 | MHz |
| Modulation Mode | Handset | | AM | | |
| Deviation | Handset | 100 | | 100 | KHz |
| RF Output Power | Handset | | | 10 | uW |
| Transmitter Battery | Handset | | 12 | | VDC |
| Demodulation Mode | RF | | AM | | |
| Receiver Sensitivity | RF | -90 | | -100 | dBm |
| Date Rate | RF | | 1K | | Hz |
| Operational Temperature | | -20 | 25 | 85 | C |

ACCESSORY OPTIONS



Additional Remote Control Transmitter



Uninterruptible Power Supply in case of power failure



External Piezo Security Alarm

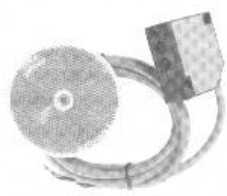

Photo Cell Additional Safety Feature



External Key & Switch



Interface Board for Optional extras



External Counter

!WARNING All 240V connections must be fitted by qualified Electrician / Personnel

NB: Max. Load 100W

Warranty

A. The manufacturer, Gliderol Roller Doors Ltd (the Manufacturer), a division of Gliderol International Pty Ltd, of 1 Doxford Drive, South West Industrial Estate, Peterlee, Co. Durham, U.K. warrants to the original purchaser (the Vendee) that the Glidermatic GRD (the Unit) including every major component thereof will be free from defects in materials and workmanship in normal operation for a period of twenty four (24) months from the date of installation where installation is effected by the Manufacturer or one of its Authorised Distributors or otherwise from the date of purchase.

B. (1) Where the unit has been installed by the Manufacturer or an Authorised Distributor, the Manufacturer warrants such installation shall be free from defects in material or workmanship and that the Vendee shall be entitled to free service by the Manufacturer or its Authorised Distributors to remedy any such defect. Any service calls made by the Manufacturer or its Authorised Distributors for the purpose of adjustments and, in the opinion of the Manufacturer not to remedy a defect to which this Warranty relates will be paid for by the Vendee.

B. (2) Where the unit has not been installed by the Manufacturer or its Authorised Distributor, in addition to any warranty offered by the installer, the Manufacturer will within twenty four (24) months after the date of purchase, and after notification of the defect by the Vendee and on the return of the defective part of the Unit repair or at its option, replace any defective part of the Unit without charge provided disconnection, re-installation and freight costs shall be borne by the Vendee.

C. Vendee to give Notification and Proof

The Vendee must immediately notify either the Manufacturer or its Authorised Distributor in the event of any alleged defect in the Unit and must establish to the reasonable satisfaction of the Manufacturer or its Authorised Distributor the date of purchase or installation (as the case may be) by way of invoice or the completed Warranty Form contained in this Manual.

D. Future Modification

The Manufacturer reserves the right to modify any existing or future models of the Unit without incurring any obligation to incorporate such modifications in Units already manufactured or to which this Warranty may relate.

E. General

Subject to paragraph F and G the obligations of the Manufacturer or its Authorised Distributor under this Warranty are limited to those contained above and this Warranty is the only warranty made by the Manufacturer and exclusively and expressly in lieu of all other warranties permitted to be excluded by law

whether these warranties are express, implied, under common law or by statute and the terms of the warranty may not be modified by person, firm or corporation other than the Manufacturer.

F. Exclusions

This Warranty does not extend to or affect the Manufacturer or its Authorised Distributor in the event that any defects or malfunctions of the Unit are due to or result from:

1. Lack of proper care or maintenance of the Unit.
2. Incorrect, improper or unreasonable use.
3. Faulty installation or adjustment which is not carried out by the Manufacturer or its Authorised Distributor.
4. Failure to observe any instructions or directions provided with the Unit or given to the Vendee by the installer.
5. Attempted modifications or repairs carried out by an unauthorised person.
6. Faulty or unsuitable wiring of structures to which the unit is affixed.
7. Radio (including citizen band transmissions) or any other electronic interference.

Subject to paragraph G it is expressly declared that this Warranty does not apply to any batteries or globes supplied with the Unit or with the changing of codes on the Unit.

G. Statutory Warranties

It is expressly provided that this Warranty or any terms and conditions of it or any other literature provided to the Vendee shall not be read or applied so as to purport to exclude, restrict or modify or have the effect of so doing the application in relation to the supply of the Unit of all or any of the provisions of division 2 and 2a of Part V of the Trade Practices Act, 1974 (the Act) as amended or the exercise of a right conferred by such provision or any liability of the Manufacturer or its Authorised Distributors for breach of a condition or warranty implied by such provisions or any other condition or warranty implied by any relevant State Act or Territorial Ordinance or by the General Law and which by law cannot be excluded, restricted or modified provided that to the extent that the Act permits the Manufacturer to limit his liability for a breach of a condition or warranty implied by the Act then the Manufacturer's liability for such breach shall be limited to the payment of the cost of replacing or repairing the goods or acquiring equivalent goods.