

Declaration of Incorporation



March 2007

Issue 1 (Insulated Roller Garage Doors)

This Declaration of Incorporation has been prepared by the garage door manufacturer to signify that the accompanying garage door operator, if installed in accordance with the manufacturer's detailed instructions will meet the requirements of EN12453.

It is the responsibility of the installer to ensure that doors and garage door operators are correctly matched prior to installation. It is also the responsibility of the installer, legally described as the Responsible Person, to ensure that a suitably nominated person will confirm that the power operated door has been installed in accordance with the instructions provided by both the door and drive unit manufacturer.

It is also the responsibility of the installing company to check after installation that the power operated door and any safety devices provided are suitable for the application and are all working satisfactorily. This will permit the nominated person to attach a CE label

identifying the name of the installing company, a unique door reference number and a date of completion. The installing company should label the door and provide the documentation as specified within EN12635.

One copy of the Declaration of Conformity is to be issued to the client and one copy is to be retained by the installing company, together with the relevant two Declarations of Incorporation. In accordance with the requirements of the Machinery Directive and the UK Supply of Machinery (Safety) Regulations, these records are to be retained on file for a period of ten years.

Note.

Duplicated printed pads set out in the format of Declarations of Conformity in order to allow on site completion are available at a reasonable cost from the DSMA for both members and non-members. Alternatively, for an additional cost, a technical records file with full details of requirements and procedures for compliance, and including the necessary filing divisions, is also available.

This declaration is made by:

(V. Brockley, Managing Director)

HENDERSON
GARAGE DOORS

HENDERSON
GARAGE DOORS

U.K. Customer Services Department

Telephone: 0191 377 1441 Facsimile: 0191 377 2972

E-mail: sales@pchenderson.com

Durham Road, Bowburn, County Durham DH6 5NG, England. Telephone: 0191 377 0701 Facsimile: 0191 377 1309

www.pchenderson.com

P C Henderson (Ireland) Ltd

West Link Industrial Estate, Kylemore Road, Dublin 10, Ireland. Telephone: 01626 0444 Fax: 01626 0455

www.pchenderson.ie E-mail: sales@pchenderson.ie



INVESTOR IN PEOPLE

Insulated Roller Garage Doors

Insulated roller door and Compact insulated
roller door remote control unit



Installation Instructions

Ansa RSI roller door remote control system

Contents

1	General description	8	Adding transmitters.
2	Fitting the RS I control unit. .	9	Deleting transmitters
3	Operation	10	Dip switch Settings
3.2	Function of the red LED indicator.	11	Multi- door control
4	RSI Control board- overview.	12	Photoelectric Cell Override
5	Electrical connections.	13	Fault diagnostic system.
6	Commissioning.	14	Control inhibit feature.
7	Fitting photoelectric safety sensor[s]	15	Fitting the optional aerial.
7.1	How to align the photoelectric beam[s]	16	Maintenance.
7.2	Photoelectric sensor operation and testing	17	Problem solving guide
		18	Technical specifications

Installation instructions

Please read these instructions carefully prior to commencing installation of the unit. Operate unit only when the door is in full view and free from any obstruction. No one should enter or leave the garage while the door is in motion.

I - General Description

The Ansa RS I control unit is designed to operate roller garage doors fitted with single phase tubular motor drives. Equipped with “rolling code” high security remote controls, allowing easy memorisation of up to fifteen transmitters. The unit has all the features needed for efficient, safe and reliable operation of roller doors including built-on courtesy lamp, operating button and multi- function red indicator LED.

2 - Fitting the RSI Control Unit

2.1 The electric drive motor, RSI control and photoelectric safety sensor are normally fitted to the same side of the door opening. Select a suitable position for the control unit, within sight of the door, well away from moving parts, ensuring that :-

- It can be plugged into an adjacent 13A switched socket.
- It is within the constraints of the motor lead, using a 'tidy' cable run.
- It is mounted with the built on lamp at the top.
- It is fitted at a height of at least 1.6 metres out of the reach of children.
- It is fitted inside a dry room only (I.P.44 rating)

2.2 Fitting the enclosure - Refer to figure I

Remove the courtesy lamp lens from the base by squeezing the sides of the lens, disengaging the clip in the top of the lens. Remove any packaging from the lamp. Pull off the trim, and undo the two fixing screws approximately 8mm, noting that it is not necessary to completely remove the screws which remain attached to the cover. Carefully remove the cover by pulling away from the base with a slight downward movement. The packing box provides a useful fixing position guide. Fix the base to the wall using the fixing screws and plugs provided.

Note: Do not allow dust to enter the unit which could damage the electronics.

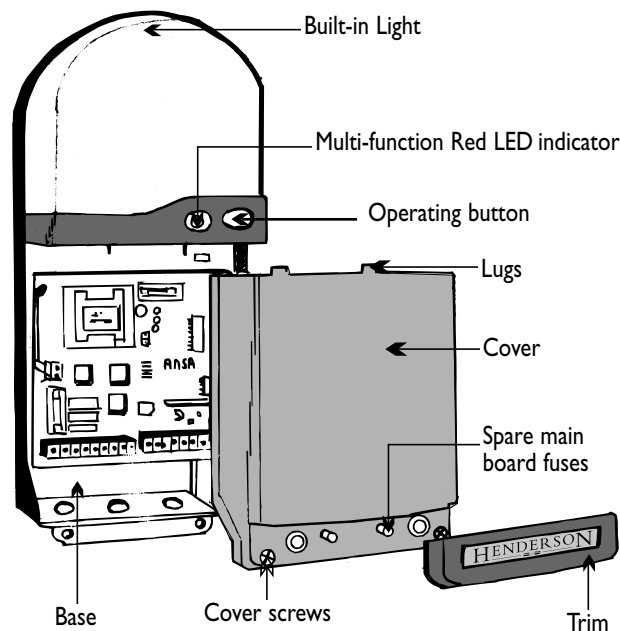

Figure I

Operation - 3

3.1 The microprocessor control unit operates in sequential impulse logic. The door can be operated using the test button, the operating button fitted to the front of the control unit, the remote control hand set or other optional controls connected to the system. Push any of the above buttons and the door will open. Push a button again and the door will close. If a button is pressed whilst the door is moving it will stop and pushing the button again will reverse the original direction.

The advanced electronics monitor the motor drive and limit switches and turn off the motor run timer as soon the door reaches a fully open or a fully closed position. There is no need to wait for the run time to expire before closing a recently opened door and accidentally operating the photoelectric safety sensor will not affect a recently closed door.

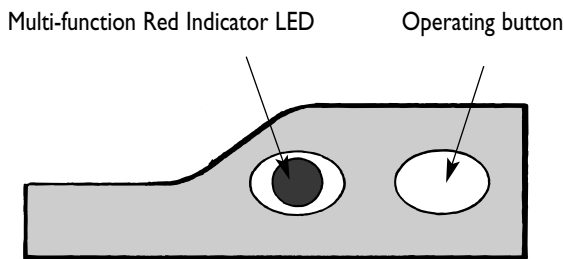

Figure 2

3.2 Function of red LED indicator

Operation

Continuous on - Power is switched on [stand-by mode]

Flashing quickly - Safety input is active [e.g. photo- beam is obstructed]

Flashing slowly - Diagnostic self-test is active [Indicates fault in control wiring, control device or photo-electric sensor]. Door is inoperable until the fault is corrected.

3.3 Courtesy lamp.

The courtesy light will switch on for four minutes whenever the door is operated and turn off automatically.

Control Board Overview - 4

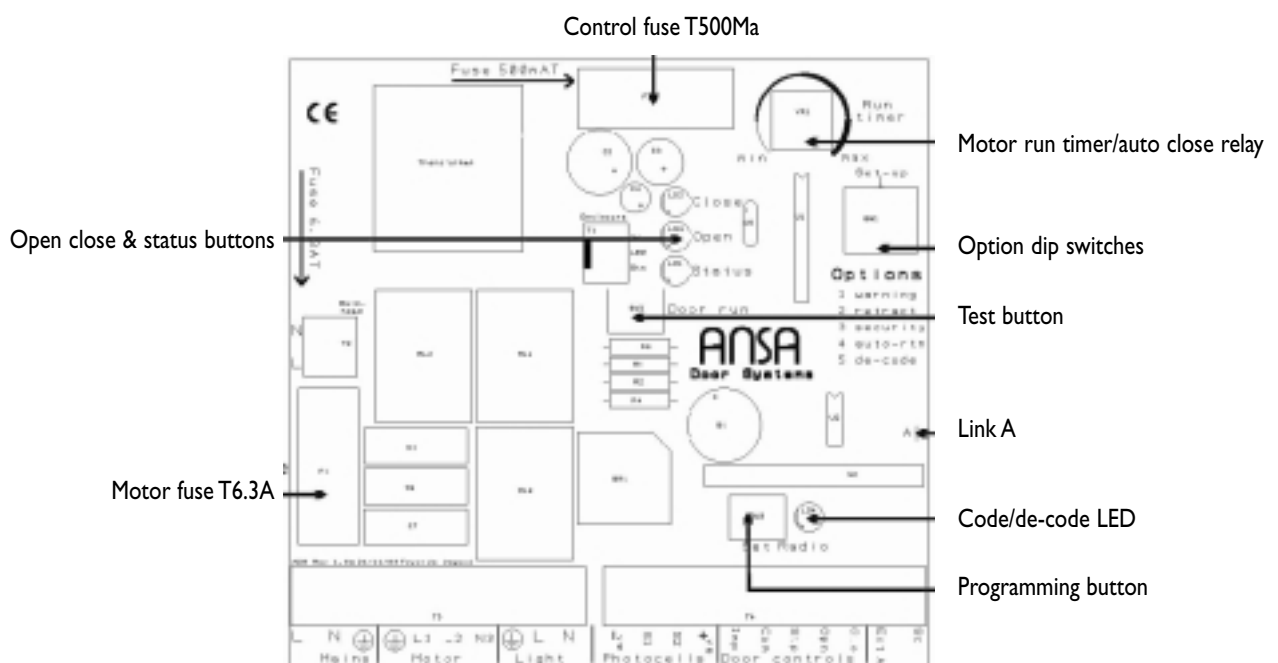

5 - Electrical Connections

Always switch off the mains power supply before making any connections!. Electrical connections should be carried out by a competent person, if in doubt consult a qualified electrician!

Cables should enter the control unit through the cable glands fitted to the bottom of the RSI unit.

5.1 POWER - The 240v A/C input should be connected from an adjacent 13 amp 3 pin switched socket. The plug must be fitted with a 5 amp fuse. Connect to terminals marked L, N, E, MAINS

5.2 MOTOR - Connect the motor lead to the terminals marked E, L1, L2 N3 MOTOR. The blue motor neutral cable must be connected to the terminal marked N3. Connect the yellow/green earth cable to the terminal marked E. Connect the brown and black motor power cables to terminals L1 & L2. Ensure that motor direction matches the open and close LED'S if necessary interchange the motor cables at terminals L1 & L2.

5.3 ADDITIONAL LIGHTING - Terminals marked LIGHT, E, L, N, provide a 240 volt ac output which functions the same as the built on light. Lighting switches on for 4 minutes whenever the door is operated and turns off automatically. Maximum load 200 watts. The output should be connected to a class 2 double insulated luminaire.

5.4 PHOTOELECTRIC SAFETY BEAM - ANSA RSI can be connected to one or two photoelectric sensors which must be capable of operating from a 24v DC supply voltage, and must have a normally closed NPN output signal. If two photocells are used they should be the same type.

OPERATION - The safety beam has no effect on an opening door. Breaking the safety beam prevents closure of an open door, and will also stop and re-open a closing door.

CONNECTING A SINGLE PHOTOELECTRIC CELL - Remove the factory fitted link connecting -VE & S1. The supply to the photocell is connected to the terminals marked -VE & +VE. Connect the output signal to terminal S1, (retain the link connecting S1 & S2).

CONNECTING TWO PHOTOELECTRIC CELLS - Remove the factory fitted link connecting -VE & S1 and S1 & S2. The supply to the photocell is connected to the terminals marked -VE & +VE. Connect the output signal from the first sensor to terminal S1. Connect the output signal from the second sensor to terminal S2.

5.5 OPTIONAL DOOR CONTROLS - A wide range of additional door controls may be connected to the unit, i.e. key switches, push buttons, digital key pads etc.

IMPULSE DEVICE - A push to make (normally open) push button or key switch can be connected to terminals COM & IMP, this provides an OPEN - STOP - CLOSE - STOP sequential operation.

STOP PUSH BUTTON - A push to break (normally closed) push button or key switch can be connected to terminals marked COM & STP. Activation will stop the door immediately regardless of it's position. If used remove the factory fitted link connecting COM & STP.

DOOR OPEN DEVICE - A push to make (normally open) push button can be connected to terminals COM & OPN. Operation will open the door or re-open a closing door.

DOOR CLOSE DEVICE - A push to make (normally open) push button can be connected to terminals COM & CLO. To provide a door close signal.

Commissioning - 6

6.1 If possible, manually operate the door and position the door curtain half open. Switch on the mains power supply and check that the multi-function red LED is on. The on board status L.E.D should be illuminated green.

6.3 Adjust the motor limit switches.

Carefully adjust the limit switches following the door manufacturer's instructions. For screw adjuster type limits turn on Dip switch 3. Press the operating button and ensure that the motor direction matches the open and close circuit board LED'S, if necessary switch off the mains power supply and interchange the motor cables at L1 and L2.

Note-the motor unit has an inbuilt thermal trip which activates if the motor gets too hot after repetitive use, causing the motor to cut out. If the thermal trip operates wait approximately 10 minutes for the motor to return to normal operating temperature

When the limit switches are correctly set turn off Dip switch 3 for normal operation.see fig 4

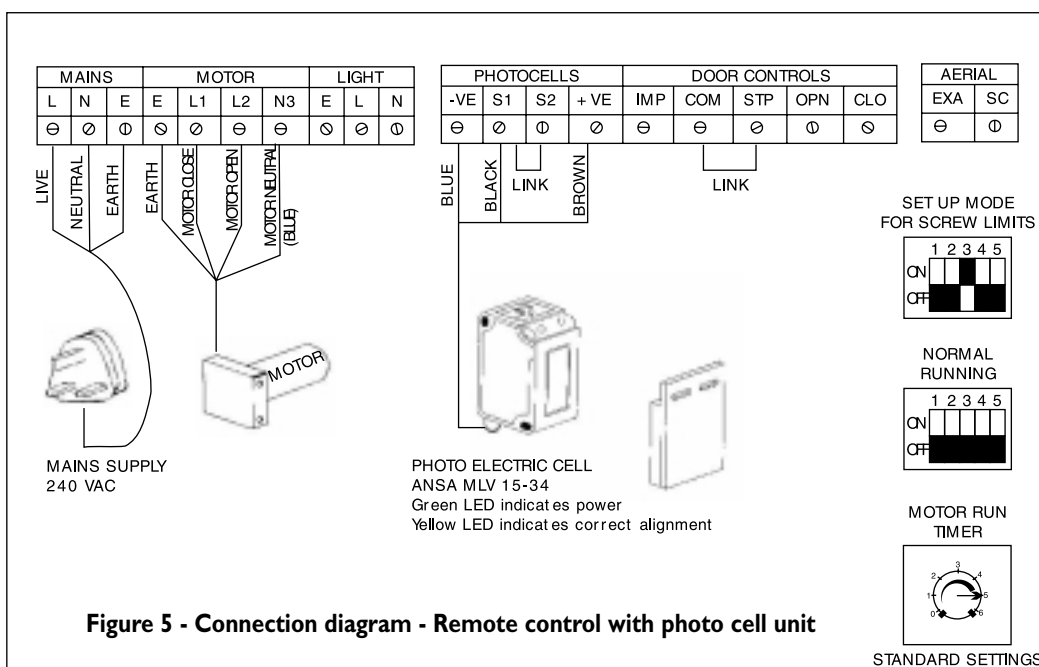
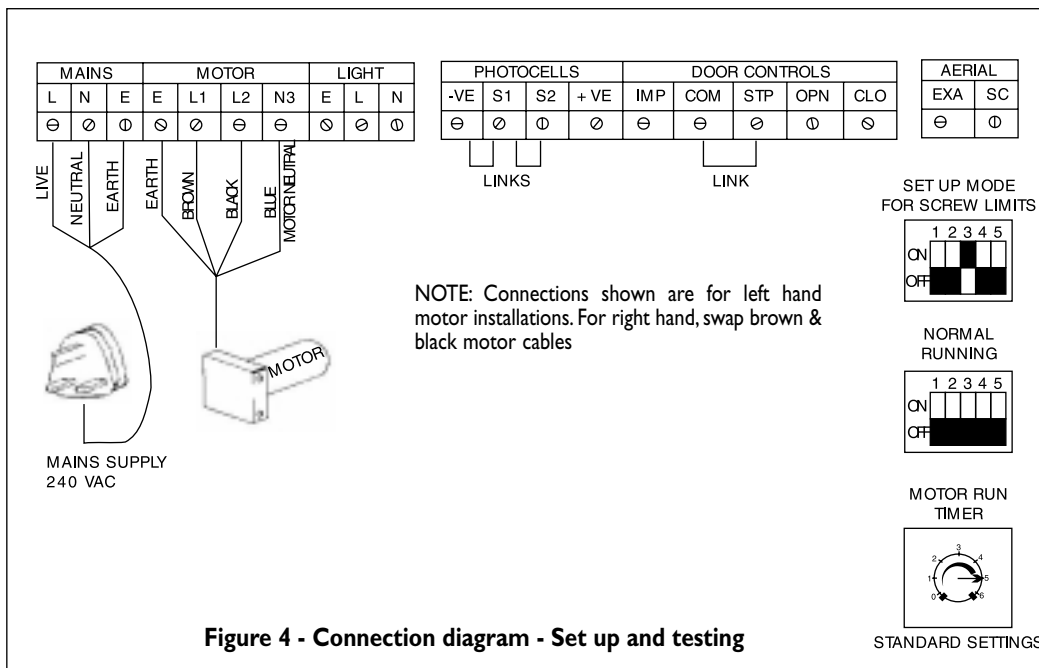

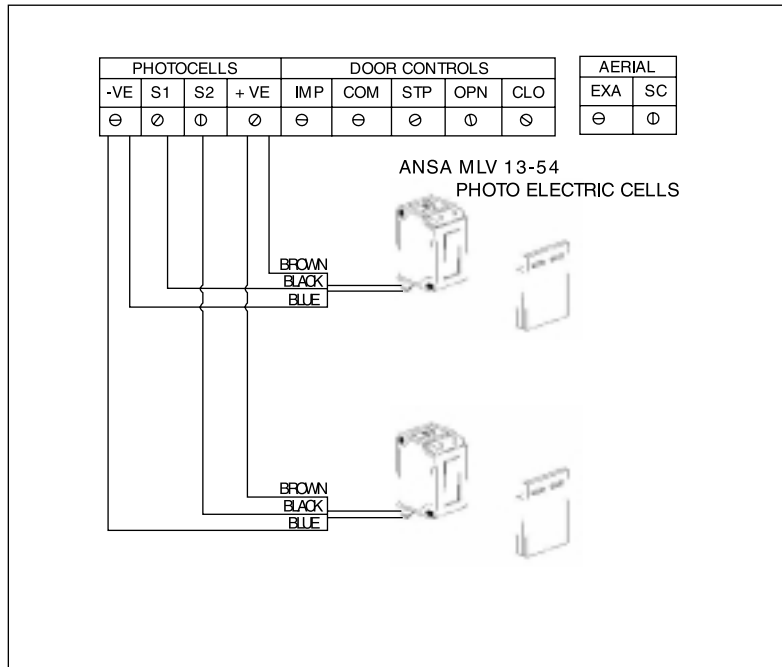

Figure 6 - Connection diagram - Installing 2 photoelectric cell units

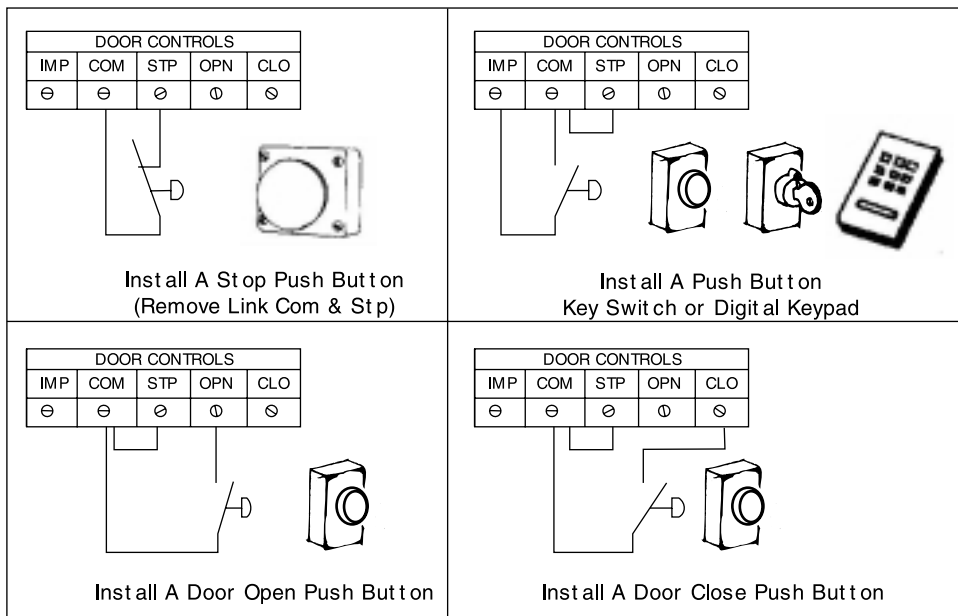

Figure 7 - Connection diagram - Option controls

Fit the Photoelectric Safety Sensor - 7

Refer to figure 8.

Fix the photo cell brackets to the door guides at a recommended height of 300mm using the self-drilling screws provided. Fit the photoelectric sensor to the pivot bracket using 2 No M3 x 25mm nuts and bolts provided ensuring that the flat and shake proof washers are correctly fitted. Attach the pivot bracket to the photocell bracket using 2 No M4 x 15mm nuts and bolts provided. Fit the photocell reflector to the opposite bracket using 2 No M4 x 15mm nuts and bolts provided.

The diagram shows a right hand installation. The photo sensor can be fitted left hand using a similar assembly.

Note: the diagrams show the standard assembly, for extra wide doors, doors fitted with mechanical stops to the bottom rail or doors subject to high wind pressure it is possible to turn the pivot bracket around which conveniently sets the photoelectric sensor slightly further away from the door curtain.

7.1 How to align the photoelectric sensor(s) [Ansa Type MLV 13/54]

The green L.E.D is illuminated when the photoelectric cell is switched on. For reliable operation it is important that the photo beam is "centred" on the reflector using the following set-up procedure: Adjust fixing screws A & B so that the photoelectric sensor and pivot bracket can be moved up and down and left to right. Move the sensor until the yellow L.E.D illuminates. Carefully move the pivot bracket left and right to obtain reference points where the yellow L.E.D goes out. Set the pivot bracket in the mid position and tighten screws A.

Now similarly move the sensor up and down again noting the reference points where the yellow L.E.D goes out. Set the sensor in the mid position and tighten screws B.

With the photocell correctly adjusted and working the green and yellow L.E.D's fitted to the sensor and the red indicator L.E.D fitted to the control unit will be illuminated. Breaking the photo-beam will switch off the yellow L.E.D fitted to the sensor and cause the red indicator L.E.D to flash quickly, confirming correct operation.

7.2 Photoelectric Sensor Operation And Testing

The safety beam has no effect on an opening door. Breaking the safety beam prevents closure of an open door and will also stop and re-open a closing door.

The ADS v1.1 software fitted to the RS I control unit continuously monitors the photoelectric sensor. If a fault is detected the system prohibits closure of the door.

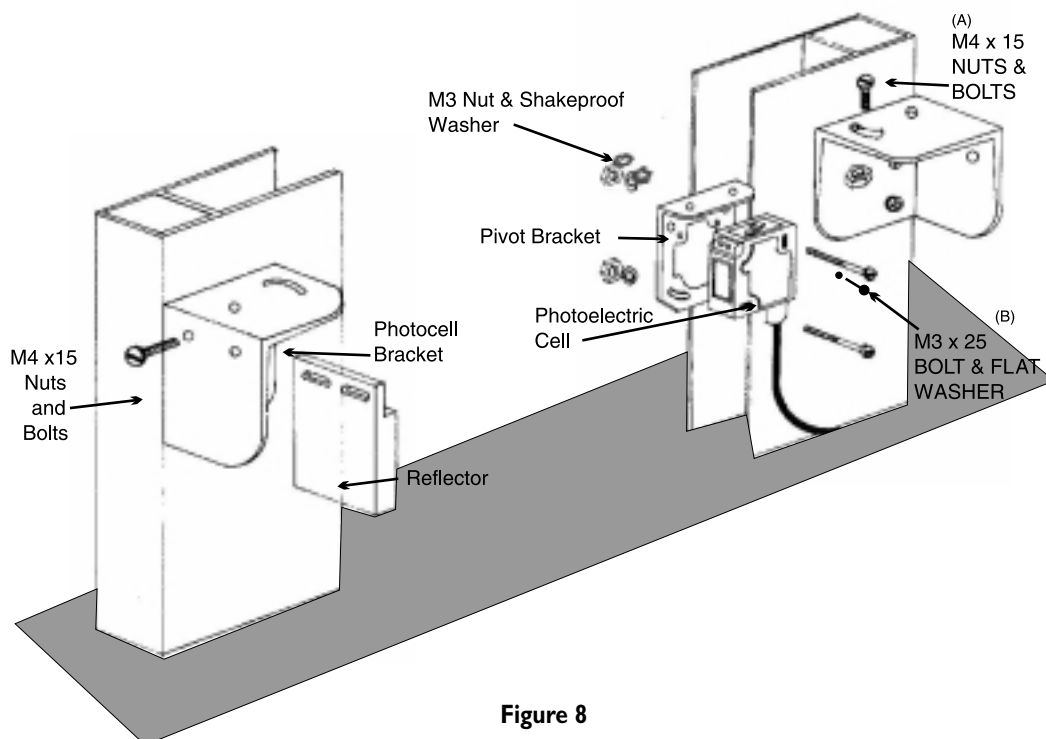

Figure 8

8 - Adding Transmitters

To add extra transmitters

Press the operating button for 5 seconds and release when the red LED indicator goes out. The LED will flash once to confirm Add Mode. Take the new transmitter to be added and press the button once. The red LED indicator should flash once. Repeat this for every new transmitter to be added to the system. After the last transmitter has been added either wait 30 seconds or press the operating push button once to reset to normal operation.

The remote control system uses the latest “rolling code” technology. Hand transmitters supplied are pre-programmed. The receiver can memorise the codes of 15 transmitters. Upgrade memory chips are available for 31 or 62 transmitters by special order.

9 - Deleting Transmitters

It is not possible to selectively delete transmitters and selecting delete mode will erase all transmitters from the system. Switch off the power supply to the unit and remove the front cover. Turn on Dip switch 5 and re-power the unit. The circuit board mounted yellow “set radio” LED will illuminate for 5 seconds, all transmitters are now deleted. Switch off the power supply, turn off Dip switch 5 and re-fit the front cover. Transmitters can now be reloaded using the “Add Transmitters” procedure.

10 - Dip Switch Settings

The RSI control unit has five onboard Dip switches which control the following features.

10.1 Dip switch 1 warning. When switched on, the courtesy light will flash three times before the door moves.

10.2 Dip switch 2 Retract. When switched on, selects partial retract. If the photocell is activated the door retracts 200mm instead of returning to the fully open position.

10.3 Dip switch 3 Security. When switched on, extends the motor supply feed for the duration of the motor run timer which assists adjustment of screw type motor limit switches Dip switch 3 is normally turned off. Additionally for doors having an externally fitted manual override system, switching on Dip switch 3 selects a security system. If the manual override system is used to force open the door, the system will power down the door to the closed position.

Note- When using the security system it is important to accurately set the motor run timer. operate the door from the fully closed to the fully open position and adjust the run timer so that the circuit board “open” LED goes out five seconds after the door arrives at the fully open position. See Fig 9.

10.4 Dip switch 4 Auto- Close. This option is normally turned off. Turning on Dip switch 4 selects an automatic time delay self closing function. The time delay begins when the door is fully open and is reset if the photoelectric safety beam is broken. The auto-close delay is dependant upon door size and operating speed. Set the motor run timer as described in “security”, the corresponding auto close delay is shown in Fig 9.

Note ; Selecting Auto-close increases the level of automation and to comply with relevant safety standards we recommend the installation of additional safety devices ie, safety edge system or additional photoelectric sensor.

10.5 Dip switch 5 Decode

Used when removing lost or stolen transmitters from the receiver memory. [see 9 Deleting Transmitters.]

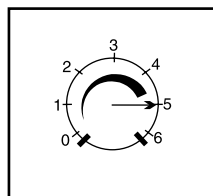

NOTE: Position 5 is the standard factory setting

Timer Setting	Motor Run Time (seconds)	Auto close Delay (seconds)
0	2	5
1	8	18
2	16	34
3	26	46
4	35	60
5	44	70
6	52	90

Figure 9 - Run Timer Settings

Multi-door Control - I I

Three types of transmitters are available, 1, 2 or 3 buttons, therefore up to three doors each fitted with a standard RS I control unit can be controlled independently using a single transmitter. Simply select the transmitter button you wish to use with a particular door and programme the transmitter as per section 7 "Adding Transmitters".

Photoelectric Cell Override - I 2

If the safety input is active, the system automatically switches to "Photoelectric Cell Override Mode" which enables controlled closure of the door in "dead-man" operation. Using a hand transmitter or the built-on operating button and with the door in full view press and continue to hold the button. The red LED indicator will change state from flashing to on. The button is monitored and after five seconds the door will close in "deadman" control. Releasing the button will stop the door and the above procedure can be repeated to continue closing the door. Activation of the safety circuit is indicated by the red LED which will flash quickly, this could be due to:- A loose or poor connection to terminals -Ve, +Ve, S1 or S2. A dirty photocell sensor lens or reflector. Poor alignment of the photoelectric sensor and reflector.

Fault Diagnostic System. - I 3

The microprocessor monitors the circuit board, low voltage control wiring, control devices connected to the system and photoelectric sensor[s] and detects possible faults. If a fault is detected the door cannot be operated and the red LED will flash slowly. The power supply should be switched off until the fault is found and corrected

Control Inhibit Feature. - I 4

In some instances it may be helpful to switch off the controls operating the door temporarily without turning off the mains power supply or erasing transmitter security codes. [For example during holiday periods]. To activate this feature simply press and hold the operating button for approximately 12 seconds and wait until the red indicator LED flashes slowly. To return to normal operation switch off the power supply to the control unit for five seconds and then switch back on.

Fitting the Optional Aerial. - I 5

The circuit board incorporates a built on aerial for the remote control receiver which is ideal for most applications.

15.1 An optional aerial is supplied which can be fitted as follows: Pass the 135mm stainless steel wire aerial through the small hole in the base of the RSI control unit and connect to the terminal marked "EXT A". Snip the wire link marked "A" on the circuit board, this is located on the right hand side of the board just above the receiver card.[see Fig 3]

15.2 It is also possible to fit a 'remote' aerial. Connect via coax cable with the inner to terminal "EXT A" and the screen to terminal "SC", again snipping link "A"[see Fig 3]

Maintenance. - I 6

16.1 Safety reverse check :-Once a month check the system for correct operation. Using a transmitter or the operating button open the door, stand inside the garage, close the door and whilst it is moving block the photo beam (using a piece of cardboard or similar) The door should stop and then reverse either partially or to the fully open position depending on Dip switch 2 setting. The red LED indicator should flash quickly when the photocell is blocked.

16.2 Keep the photo sensor lens and reflector clean using a soft damp cloth.

16.3 Keep the RSI control unit and lens clean, occasionally wipe with a soft damp cloth.

17 - Troubleshooting Guide

Note ;Always switch off the power supply before attempting to repair the door or control system.!

Faulty operation -- Red indicator LED is off - see 17.1.

Faulty operation -- Red indicator LED is on - see 17.2

Faulty operation -- Red indicator LED is flashing quickly - see 17.3

Faulty operation -- Red indicator LED is flashing slowly - see 17.4

Remote control transmitter problems - see 17.5

17.1 Faulty operation, the Red indicator LED is off. This indicates a power failure problem.

Check the power supply is live at the socket outlet.

Check the fuse in the 13a plug and fit a new 5A fuse if necessary.

Check both control board fuses, spares are supplied, fitted to the control unit cover. The main PCB fuse is a T 5 A 250 V [dia 5 mm x 20 mm , --see Fig 3]. The control PCB fuse is a T 500 Ma 250 V [dia 5mm x 20 mm , -- see Fig 3]

Check the security of the mains power cable at terminals L,N and E. If no fault is found, repair or replace the control board.

17.2 Faulty operation, the Red indicator LED is on. This indicates a possible problem with the motor drive.

Temporarily switch on and check the control board status LED -- if this is green:- The motor thermal trip may have operated. wait ten minutes for the motor to cool down. Switch off and check the security of the motor cables at terminals E,L1,L2 and N3.

Check the motor drive and limit switches. If the control board status LED is red :- Check the security of the link wire interconnecting terminals Com & Stp [if fitted]. If a stop control device is fitted, check the operation and condition of cables connecting this to terminals Com & Stp.

17.3 Faulty operation , the Red indicator is flashing quickly. This indicates that the safety circuit is active.

Clean the photoelectric sensor and reflector.

Check the alignment of the safety beam.

Check the condition of cables connecting sensor[s] to terminals Ve, +Ve, S1 & S2. If a single photoelectric sensor is fitted check the security of the link interconnecting terminals S1 & S2.

Operate the door using the photocell override procedure see section 12 and if necessary renew a damaged sensor or reflector.

17.4 Faulty operation , the Red indicator is flashing slowly. This indicates that the self-test diagnostic circuit has activated.

Check that terminals Com & Stp are interconnected using a link wire or stop push button before switching the mains power supply on.

Check that operating button next to the Red LED “clicks” when pressed.

Check for short circuits in any control devices or cables connected to terminals Com, Imp, Opn and Clo. [if fitted].

The photoelectric sensor may be faulty disconnect sensor[s] and temporarily bridge terminals -Ve & S1 and S1 & S2.

Switch off the power supply for 5 seconds and re-power the unit to reset the system. If no fault is found, repair or replace the control board.

17.5 Remote control transmitter problems.

The red LED on the hand set should illuminate when the button is pressed, if it does not- replace the battery in the transmitter. If the LED is dim the battery is low and the operating range will be reduced.

Technical Specification- 18

Supply Voltage	220-240 VAC
Transformer Power	3 VA
Power Relays	12 A - @ 230 VAC
Operating Temperature	-15 to +55 deg.C
Enclosure Rating	IP 44
Courtesy light	40 watts maximum.
Accessory Power Supply	24VDC --150 Ma
Control Logic	Eeprom microprocessor.
Safety Input	NPN
Frequency	433.92 Mhz
Security-Rolling Code	Keeloq.
Dimensions	300mm H x 130mm W x 74mm D

INSTALLATION DETAILS

Installation Address; _____

Installed By; _____
Company; _____
Date; _____
Tel No; _____

SERVICE HISTORY

Date; _____ Engineer; _____ Comments; _____
Date; _____ Engineer; _____ Comments; _____
Date; _____ Engineer; _____ Comments ; _____
Date; _____ Engineer; _____ Comments; _____
Date; _____ Engineer; _____ Comments; _____

