

Installation Instructions For

TRACKED

Unframed Double Metal/Timber Garage Door and Unframed single (over 7' 6" high) Metal/Timber Garage Door

(where the door is to be fitted to a timber garage door frame)

Always read the care and maintenance label thoroughly.

Part No. 002442
Issue No. 05 January 2004

PC Henderson Limited
Durham Road, Bowburn, County Durham DH6 5NG
Telephone: 0191 377 1441 Fax: 0191 377 2972

HENDERSON
A company in the Carbo Group

IMPORTANT

Check that all contents are included in the packs and that the door size is correct for the opening (see label on side of door - the label refers to the size of opening and not size of door). The following parts are supplied separately and must be checked before starting installation: -

Gear Pack 1 off - see contents list
Fittings pack 1 off - see contents list
Pre-Pack 1 off - see contents list

Installation is carried out from inside the garage. Ensure that you have adequate lighting and that all tools and fittings are inside the garage BEFORE you start.

Ensure you have the outer handle with you before leaving the garage during installation. Whilst operating the door be aware of the area it moves through. Keep people and objects out of the way. When manually operating the door, control the leading edge of the door by hand throughout the opening and closing cycle. When the door is in the open position, always ensure it is fully open/as far back as possible.

Ensure that good safety practices are employed during installation. Use good quality tools and take appropriate care if using any electrical equipment. Always check for dangerous features in the workspace such as sharp edges, protrusions or concealed or damaged electrical wiring.

CONTENTS OF THE FITTING / PRE PACK

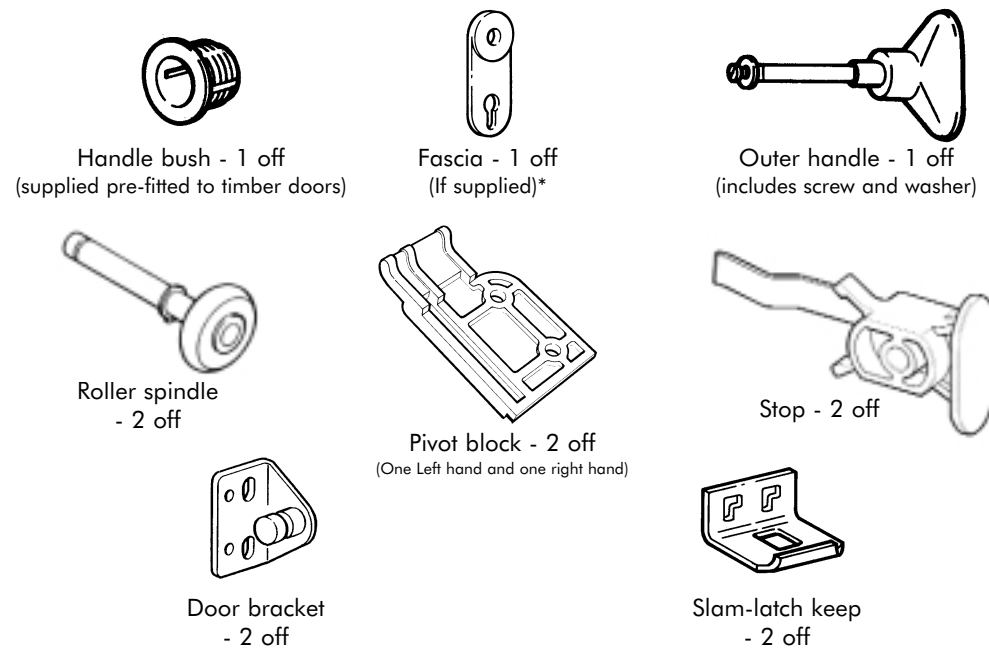

Note: If you are short of any of the items mentioned, please contact your supplier.

UNFRAMED TRACKED DOUBLE DOOR

Familiarize yourself with the terms for the door components before starting the installation. The door and components must be installed by suitably trained and qualified persons, in accordance with the instructions provided. If in doubt contact a professional installer. It is important that the installation does not deviate from the instructions provided such that all requirements of EN 12604 and EN 12453 are met and if necessary verified (from May 2004). Once installed the door should be labeled in accordance with EN 13241 (from May 2004).

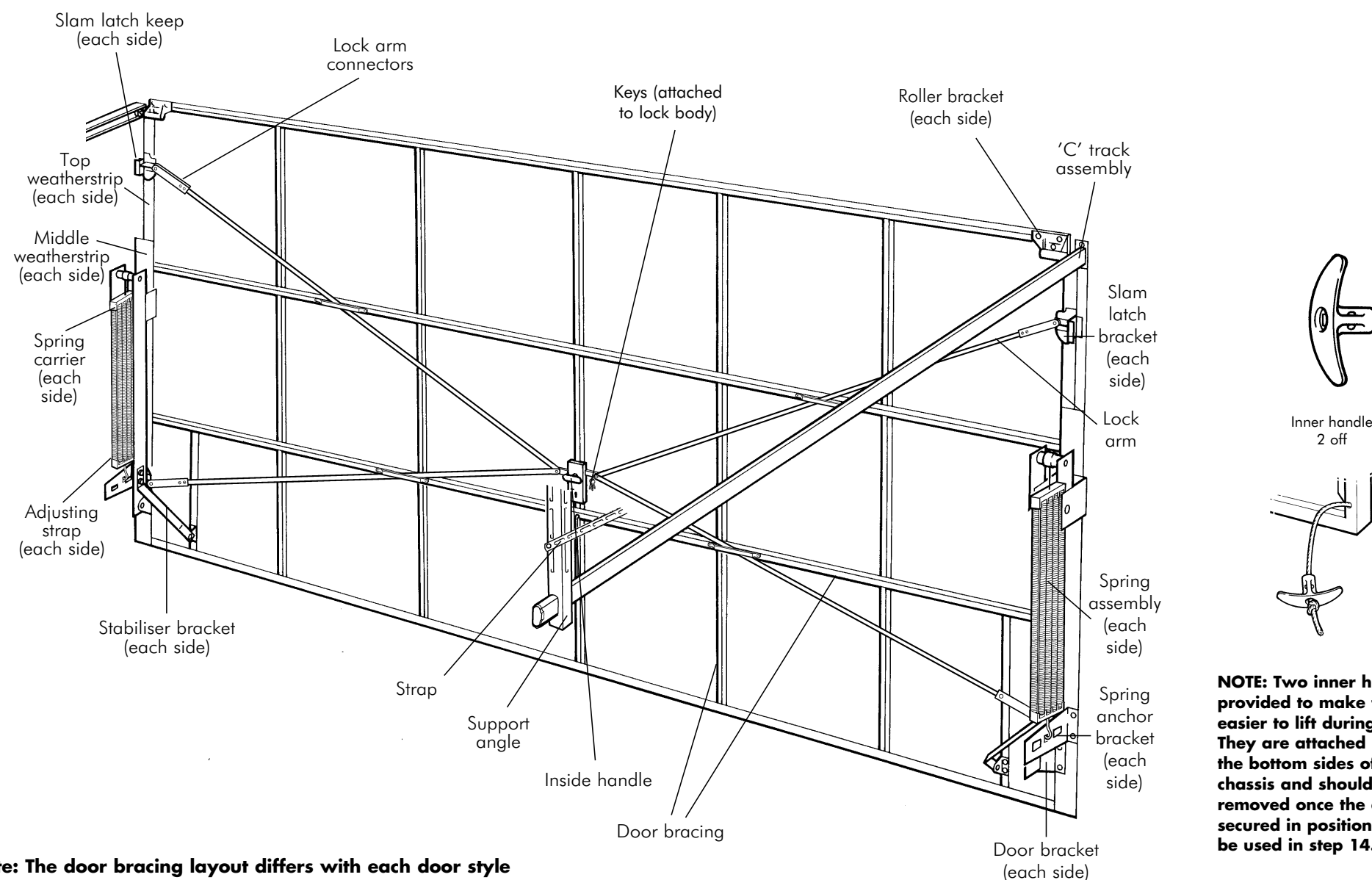

NOTE: Two inner handles are provided to make the door easier to lift during transit. They are attached by ropes to the bottom sides of the door chassis and should be removed once the door is secured in position. They will be used in step 14.

Note: The door bracing layout differs with each door style

PC Henderson reserve the right to introduce improvements to designs and changes to specifications without prior notice.

CONTENTS OF THE GEAR PACK

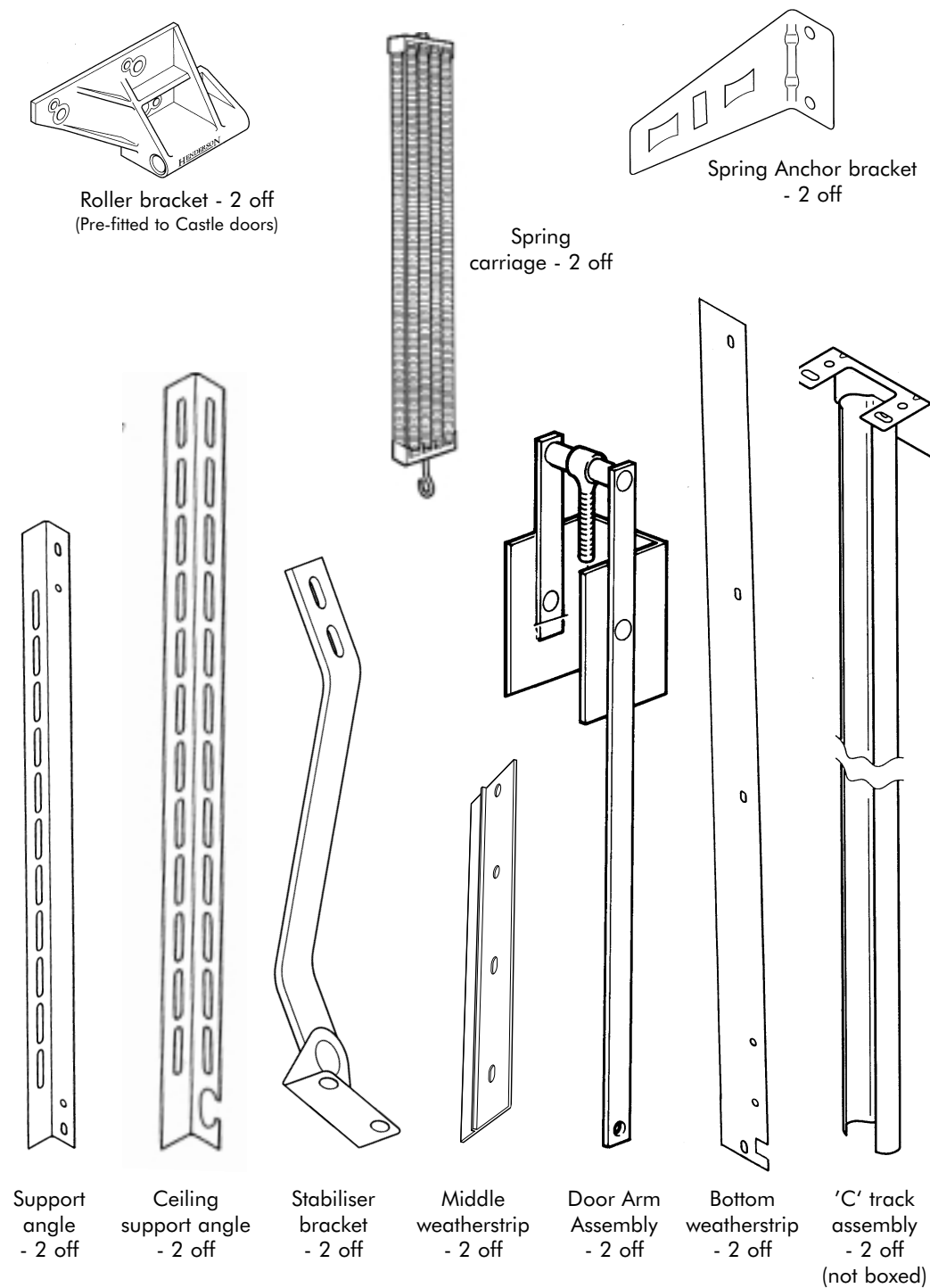

CONTENTS OF FIXINGS PACK

SHOWN ACTUAL SIZE

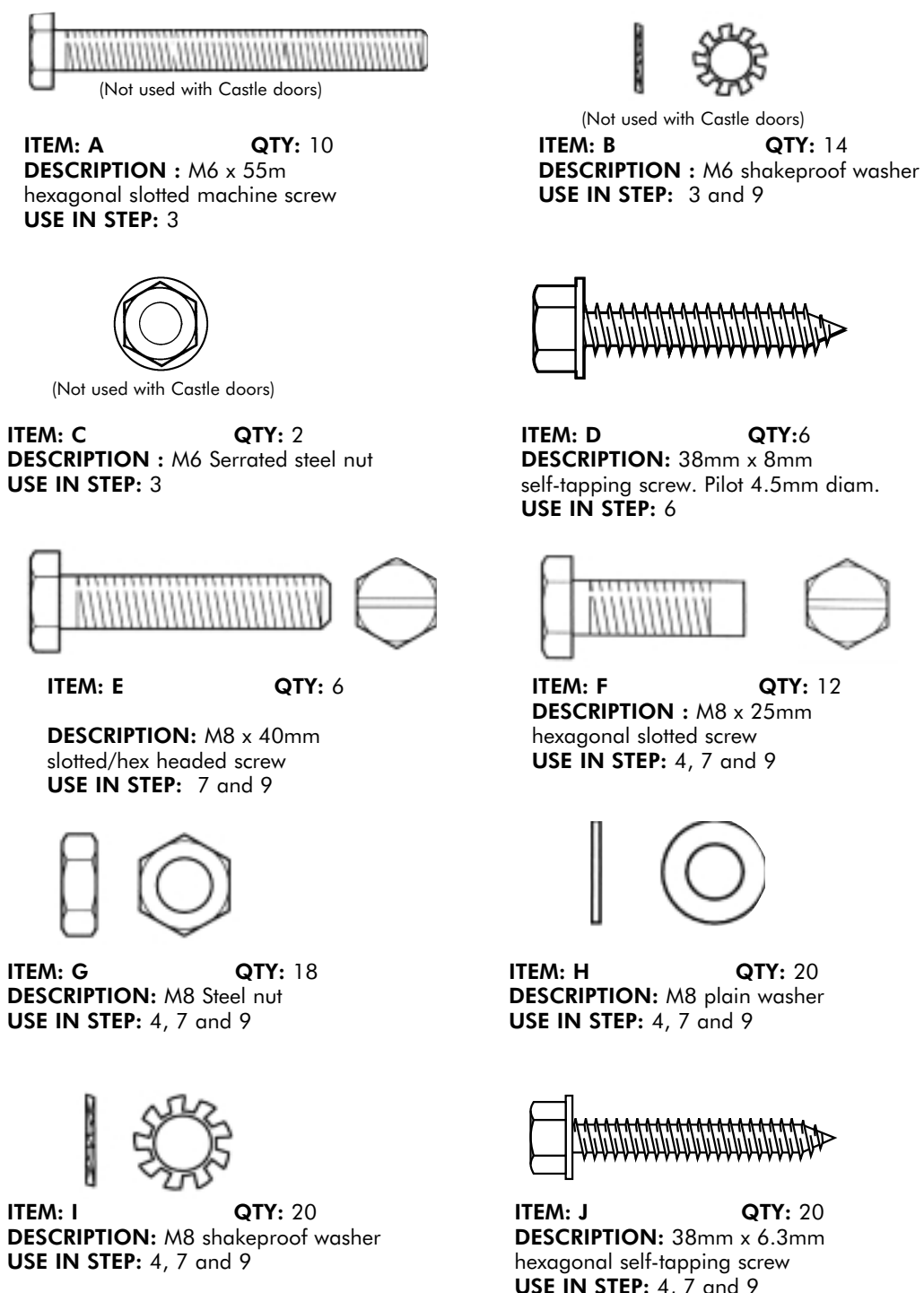

CONTENTS OF THE GEAR PACK

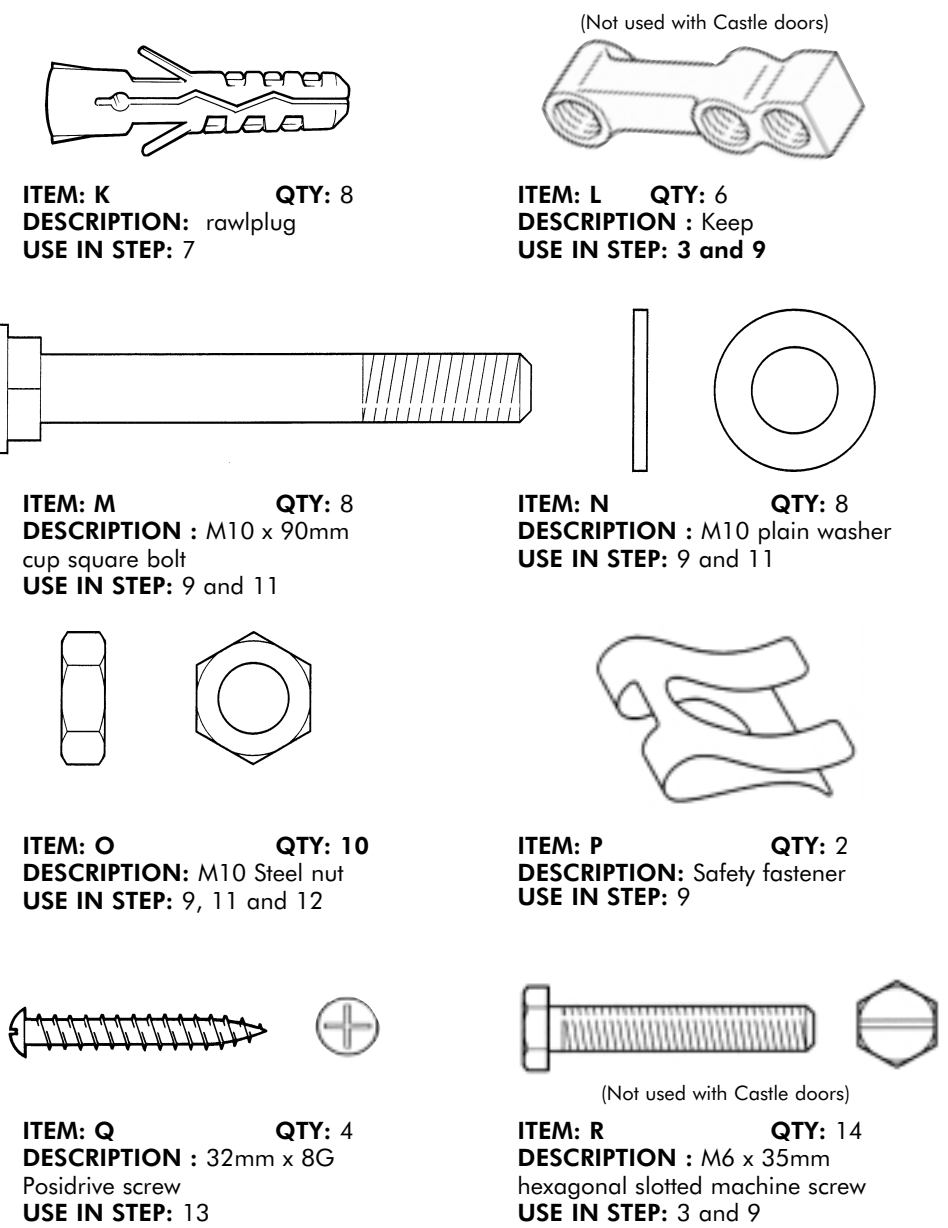

1 CHECK EXISTING FRAME DIMENSIONS

Before installation ensure a suitable good quality frame is fitted, ideally hardwood or softwood timber 76mm x 76mm.

Timber of different sizes may be used:-
Head 38mm minimum
Side 70mm minimum
The frame may be between or behind the reveals, must be secure, square and upright. It is important that the back surfaces of the frame are flush. Ensure the timber does not bow, if necessary, secure the centre of the head section with a bracket.

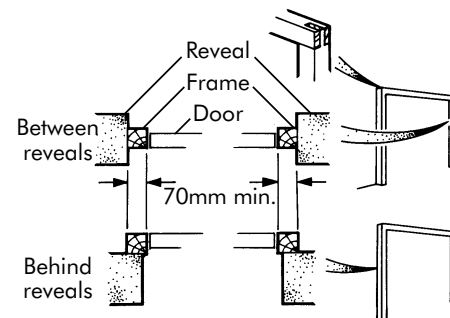

Note: All doors include the necessary clearances.

IMPORTANT: If fitting a timber frame behind the brickwork reveal, the frame and gear must be laid out prior to installing the frame to enable fixing holes to be drilled and where appropriate, coach bolts fitted through the frame. See steps 9 and 11.

2 REMOVE LOOSE ITEMS FROM THE DOOR

You should carefully remove all loose items from the door. Remove the protective wooden baton from bottom of the door if fitted. Handle the door leaf carefully to avoid damage and injury.

3 FIT THE ROLLER & DOOR BRACKETS

Premiere steel and timber doors only. For Castle doors see instruction 4.

Note - The door leaf chassis is not the same for all premiere doors. A small chassis is used on all doors with an inside frame width less than 2743mm (9'0"). To accommodate the different chassis the fittings pack is provided with two lengths of bolt M6 x 55mm slotted machine screw A, and a shorter M6 x 35mm slotted machine screw R. Please ensure that the correct length of screw is used in the following assembly. Failure to use the correct lengths of bolt may damage the chassis or fail to secure the parts.

Bolt the cast roller brackets in position on chassis as shown by fitting M6 x 55mm slotted machine screws A (or for the smaller chassis slotted machine screw R) and washers B into cast alloy keep plate L, positioned within the top chassis recess. The side machine screw must be secured using nut C and washer B within the chassis recess. Ensure that the brackets are aligned with the top of the door and the top weatherstrip. Insert the roller spindles into the brackets.

Bolt the bottom door brackets loosely in position on the chassis approximately 75mm from the bottom of the door. Fit M6 x 55mm hexagonal slotted machine screws A (use the shorter M6 x 35mm hexagonal slotted machine screws R when the inside frame width is less than 2743mm (9'0")) and washer B through the chassis into the keep plate L. These will be fully tightened in step 9.

4 FIT THE ROLLER & DOOR BRACKETS

Castle doors only. For premiere steel and timber doors see instruction 3.

The cast roller brackets are factory fitted Castle doors.

Bolt the bottom door brackets loosely in position on the chassis approximately 75mm from the bottom of the door. Fit M8 x 25mm hexagonal slotted machine screws **F** through the chassis and secure using plain washer **H**, shakeproof washer **I** and M8 steel nut **G**. These will be fully tightened in step 9.

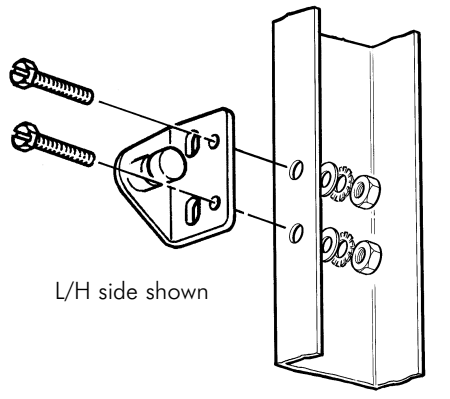

5 PLACE THE DOOR IN POSITION

Position the door centrally within the frame, ensuring that the top weatherstrips at the roller brackets are flush against the frame legs.

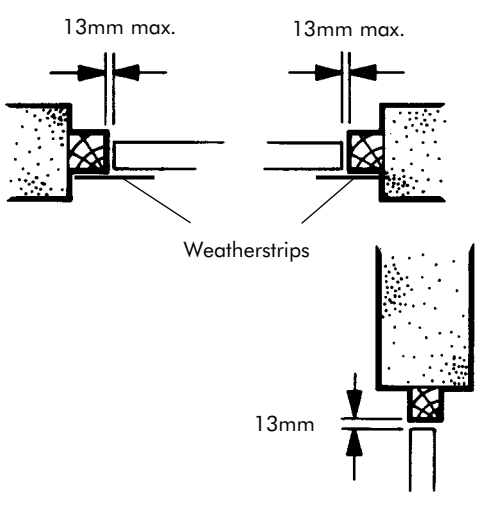

Temporarily secure the door in position. Place 2 x 10mm packers in the top of the door, lift and wedge the door on both sides until it is in contact with the packers at the top. Ensure that the following clearances are established between the door and frame.

- Top = 10 - 13mm
- Each Side (Premiere Door) = 8 - 11mm
- Each Side (Castle Door) = 10 - 13mm
- Bottom = 10 - 15mm

6 ATTACH THE 'C' TRACKS

'C' tracks are supplied pre-assembled to the front track brackets. Support the rear end of the 'C' track and place the front over the roller as shown.

Using 38mm x 8mm screw **D** and M8 washer **H**, fit front track brackets to the side frames, first through the top vertical slotted hole as shown and then through the lower vertical slotted hole. Note - a third fastener is added to each track bracket later (see step 7).

Ensure the roller spindle clearance between the cast roller bracket and spindle washer is 3mm as shown.

Note: The rollers are not required to support the weight of the door. It is important that the rollers can be moved by hand once the temporary door supports used in step 5 are removed.

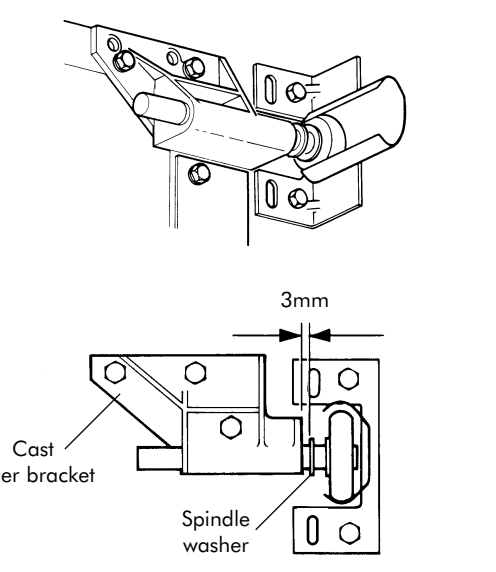

7 ALIGN THE 'C' TRACKS

Slide the adjustable ceiling support over the rear of the 'C' tracks and raise the tracks. Ensure the 'C' tracks are parallel and horizontal.

Secure ceiling support and fixing straps into the ceiling using fixings M8 x 25 bolt **F**, M8 washers **H** and **I**, M8 nut **G**, 38mm x 6.3mm screw **J** and rawplug **K** (not required if secured to timber). Ensure 'C' tracks are square to the opening. Diagonal measurement of the tracks from corner to corner should be equal. Check the position of the roller at the front of the track. Position the front track brackets to provide a small clearance at the bottom of the roller (1mm). Now fix 38mm x 8mm screws **D** and washer **H** in the remaining bottom hole of the 'C' track front bracket (see step 6).

Insert the track roller stop into the end of the track. Fix using M8 x 40mm hexagonal slotted machine screw **E**, nut **G** and washers **H** and **I**.

Important: Correctly fitted 'C' tracks will be rigid and parallel and will not require intermediate supports.

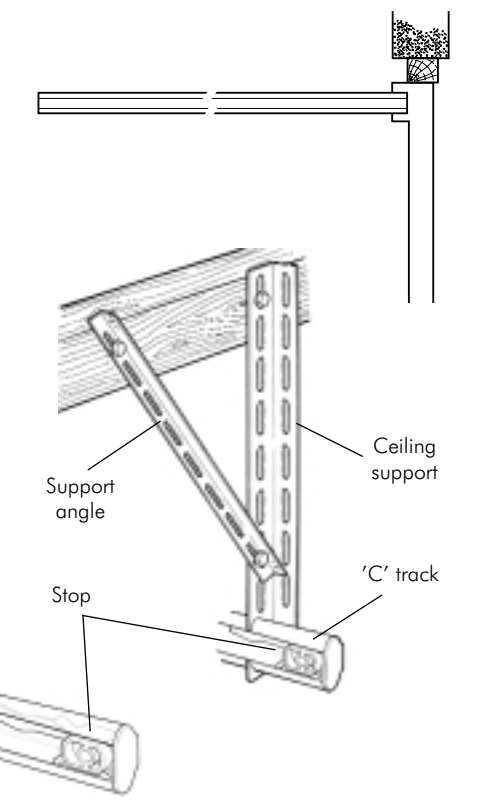

8 LOCATE PIVOT BLOCKS & MIDDLE WEATHERSTRIPS

The pivot blocks are handed. Line up the edge of the pivot block with the inside edge of the frame leg, ensuring there is a gap of approximately 3mm between the top of the pivot block and the bottom edge of the top weatherstrip guide, as shown and pilot drill the frame.

Position the plastic middle weatherstrip to align the holes correctly under the pivot block and secure using two 38mm x 6.3mm screws **J** through the holes provided. Repeat for the other side.

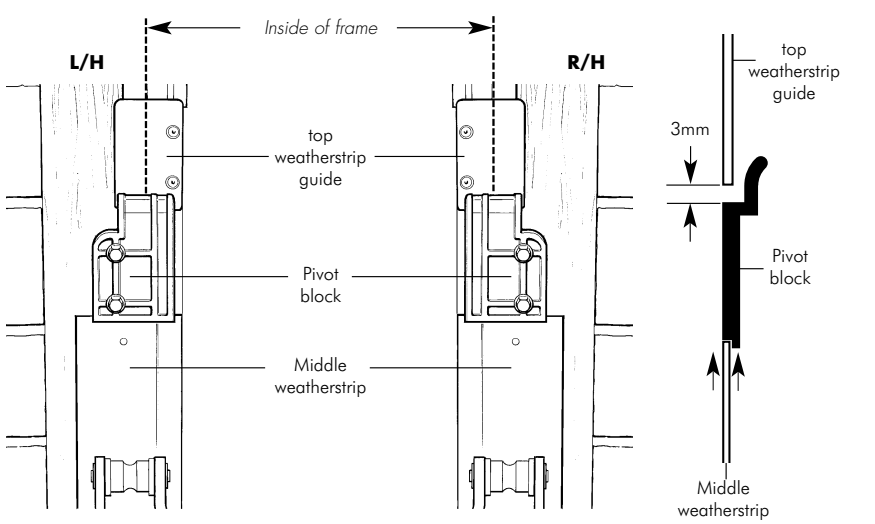

9 SECURE THE GEAR ARM JAMB BRACKET TO THE FRAME

Ensure that the pivot block and middle weatherstrip are correctly positioned. Carefully mark through the plastic weatherstrip to position the holes for the jamb bracket. Drill two 10mm holes through each side frame taking care to avoid damage to the weatherstrip. Secure the jamb brackets over the weatherstrip using M10 x 90mm cup square bolt **M** - inserted from the front of the frame leg as shown, M10 washer **N**, and M10 nut **O**.

Locate arms onto bottom door bracket and clip into place using safety fastener **P** provided. Secure bottom door brackets firmly to the door.

Premiere Steel and Timber Doors

For double doors over 2743 (9'0") wide, position the stabilizer brackets between door arms and door as shown. Secure to door arms using M8 x 40mm slotted hexagonal bolt **E**, nut **G** and washer **H**. Secure to the door using M6 x 35mm hexagonal headed machine screw **R**, washers **B** and keep **L** as shown.

Castle Steel Doors

For double doors over 2438 (8') wide, position the stabilizer brackets between the door arms and door as shown. Secure the door arms using M8 x 40mm slotted hexagonal bolt **E**, nut **G** and washer **H**. Secure to the door using M8 x 25mm hexagonal slotted screw **F**, plain washer **H**, shakeproof washer **I** and M8 steel nut **G**.

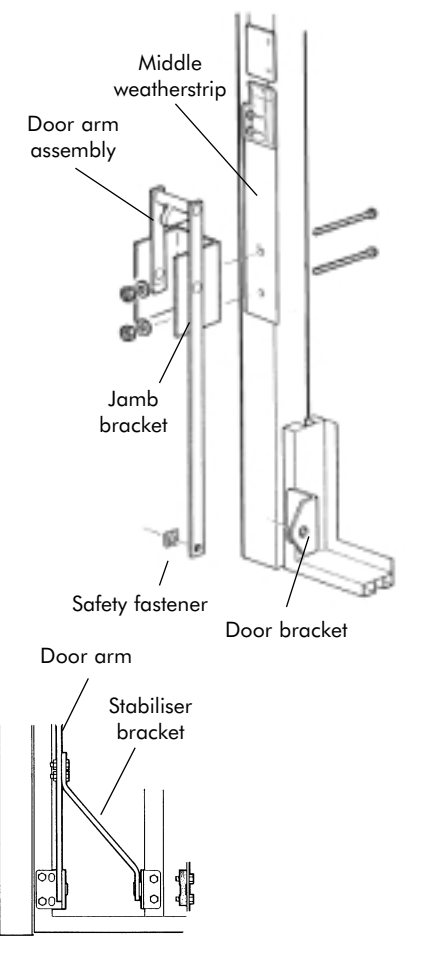

10 SECURE THE BOTTOM WEATHERSTRIPS

Butt the bottom weatherstrip against the end of the middle weatherstrip. Secure using 38mm x 6.3mm self-tapping screws **J**.

Note: On non-standard heights of door, the lower weatherstrip may require cutting from the bottom edge to suit the special opening height. If so, re-drill location holes in the lower weatherstrip using a 6.5mm drill. Take appropriate care and ensure that these operations are conducted safely.

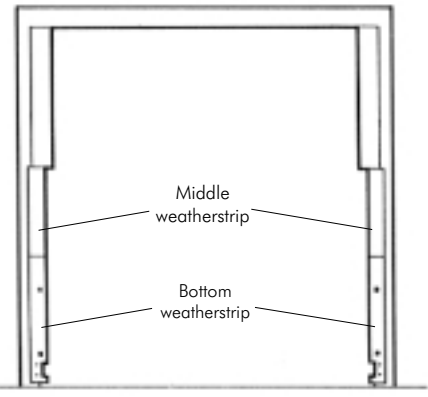

11 FIT THE SPRING ANCHOR BRACKETS

Using the lower weatherstrips as a template, drill 10mm diameter holes through the frame legs. Fix spring anchor brackets as shown using M10 x 90mm cup square bolt **M**, (inserted through the front of the frame leg), washer **N** and nut **O**.

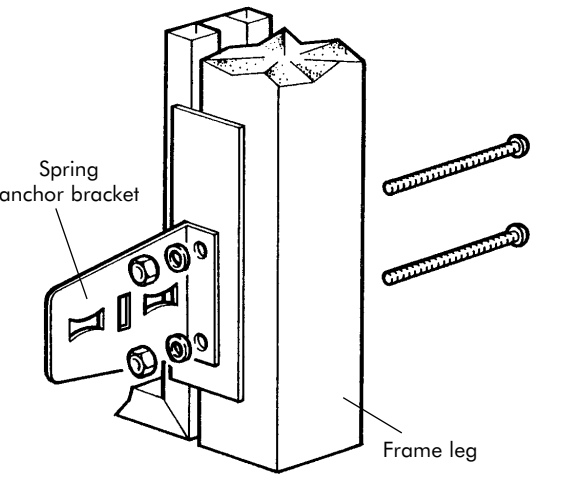

12 FIT THE DOOR SPRINGS

Remove the items being used to temporarily secure the door in position. Grip the door and simultaneously release the catches by pulling the lock arms. Slowly and carefully open the door and carefully locate a prop to hold the door safely while the springs are fitted. NOTE: The spring carriage on this door must always be orientated such that the carriage is aligned with the gap between the gear arms. Please use caution and follow the steps below carefully.

Screw one M10 nut **O** onto the gear arm threaded strap bolt - approximately 150 mm. The spring carriage assembly can now be fitted. Support the carriage and engage the gear arm threaded strap bolt into the adjustment bush in the top spring support plate. Wind the adjustment bush to draw the carriage up until the bottom hook is fully engaged in the centre slot in the spring anchor plate. As a guide, approximately 70mm of pre tension should now be applied using the spring carriage top adjustment bush. NOTE: Tension will vary depending upon the size of the door but spring tension should always be set equally on each spring carriage.

Remove the temporary support prop to establish whether the door is correctly balanced. Carefully position the spring carriage to align with the gap in the gear arms and slowly guide the door towards the closed position until the tension of the springs takes over the door movement. Ideally the door should come to rest approximately 2/3 of the way down. If necessary reopen the door and reset the temporary prop to adjust the spring tension to optimize the balance of the door. Retest the door balance until the best setting has been selected. Once set, carefully align the spring carriage top plate such that it is aligned with the gear arms. The locking nut on the adjustment bush can now be tightened to lock the top plate to the adjustment bush. The adjustment bush and tightening the parts together. Carefully operate the door to ensure that the spring carrier is aligned and that the spring carrier does not contact the operating gear. If necessary slacken M10 nut **O**, align the spring assembly with the gear arms by rotating the spring carriage and then retighten.

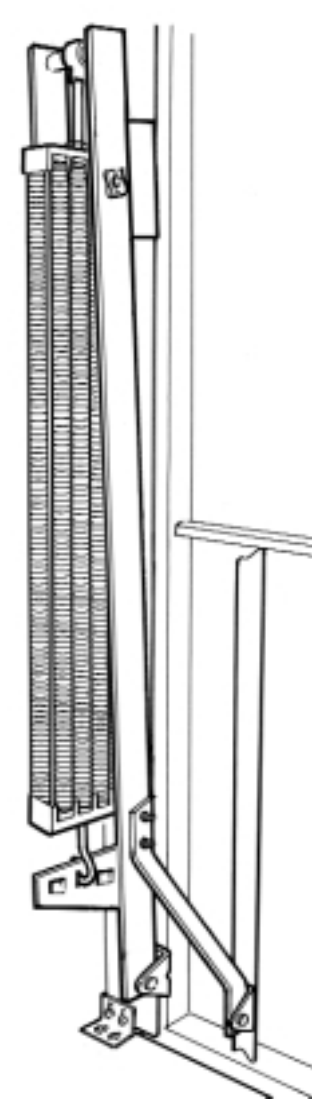

13 FIT THE TOP SLAM LATCH KEEPS

Position the slam latch keep to correctly engage over the slam latch. A 2mm clearance should be provided between the adjacent faces of the slam latch keep and the slam latch bracket to allow free movement of the door leaf at opening. Pilot drill as recommended and secure the slam latch keep in position using two 32mm x 8 gauge positive screws **Q**. Fit the second keep.

The bottom slam latches locate against the lower metal strike plate and do not require slam latch keeps to be fitted.

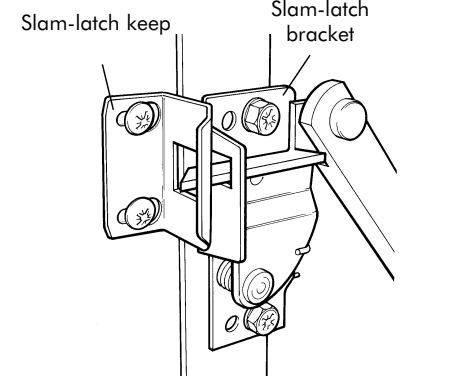

14 FIT THE LOCK

With the lock supported on the inside, push the handle bush into position from outside and fit the fascia by inserting the fixing lugs into the holes until they 'snap-in'. Remove the screw and washer from the outer handle and pass the handle through the lock as shown. Fit one of the inner handles and secure using the screw and washer just removed. Check the operation of the handle and lock mechanisms.

The second inner handle should now be attached with the rope below the lock body, on the door bracing. Thread the rope through the hole provided and knot securely to make a 'rope pull'.

Note: The fascia is not supplied for the Merlin, Doric, Durham and Victoria steel doors and is supplied pre-fitted to timber doors.

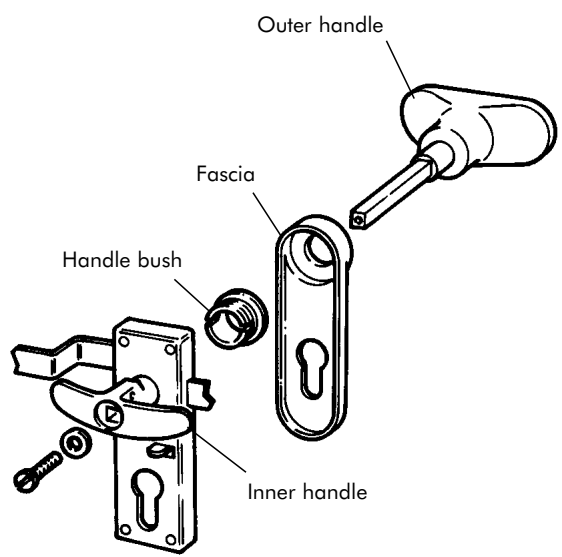

15 COMPLETING THE INSTALLATION

When the installation is complete, apply a small amount of oil to the pivot points.

Do NOT oil the 'C' tracks.

When installing into a timber frame of the recommended size, fit a 25mm x 25mm weatherbeading to the outside of the frame head as shown.

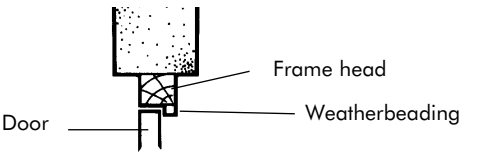

16 TROUBLESHOOTING

If you experience any problems with the operation of your door firstly check the frame and door installation as shown in steps 1 to 14 and ensure all installation steps have been followed correctly.

- PROBLEM SOLVING**
- Problem Solution 1:** The door sticks out from the frame at the bottom. Ensure roller spindles can move freely in the 'C' tracks. If necessary, reposition 'C' track front brackets. See step 6.
 - Solution 2:** Ensure there is a 3mm gap between the top weatherstrip guide and the pivot block. See step 8.
 - Solution 3:** Release the spring tension and straighten the frame leg. Fasten the frame to the wall above the jamb bracket and below the spring anchor bracket and secure the base to the floor using a suitable bracket.
 - Problem Solution:** The door 'kicks across' to one side when open. Ensure the 'C' tracks are parallel. Measure diagonally from corner to corner. The distance should be equal. Re-position if necessary. See step 7.
 - Problem Solution:** The handle is stiff to turn. Apply a drop of lubricating oil to the handle bush - see step 14.

17 DISMANTLING

The door must be dismantled with care. Always ensure that the structure is well supported during dismantling and that parts are not allowed to fall or pivot in an uncontrolled manner.

Start from inside the garage and ensure that all necessary lighting, tools and personnel are available. The door should be opened and propped securely in the opening. The door springs can be carefully removed by releasing the spring tension (see note 12 for reference). The spring carriage can now be detached from the door. Support the door leaf and carefully remove the supporting prop to allow the door to be closed in a controlled manner. Securely prop the door to resist any unintentional movement.

The gear arms can now be detached from the frame - taking care to lower the arms to the floor after removal of the fixing screws (see note 9 for reference)

Release the 'C' tracks from the ceiling supports and lower towards the front of the door. Remove the ceiling track supports (see note 7 for reference)

Detach the 'C' track front brackets from the frame taking care to support the 'C' tracks which will then detach from the opening (see note 6 for reference)

Remove the spring anchor bracket and bottom weatherstrips by removing the local fasteners (see notes 10 & 11 for reference).

Remove the top slam latch keeps to release the engagement of the slam latch (see note 13 for reference). Remove the pivot block and middle weatherstrips (see note 8 for reference).

The door can now be carefully handled; the prop supports removed and the door will release from the opening. Ensure that hands will not come into contact with any sharp edges and wear gloves if necessary. Always take care when handling heavy items.

Carefully remove the lower weatherstrips and fasteners ensuring that they are not left in the vicinity where they can be trodden or driven upon.

Dispose of all unwanted parts in accordance with best practices and legislation.