

3 048 943 RE / (Stand 10.2012) Druck 10.2012

**DE**

## **Anleitung für Montage, Betrieb, Wartung und Demontage**

Sectionaltore für Garage Baureihe 40

**EN**

## **Instructions for Fitting, Operating, Maintenance and Dismantling**

Series 40 Sectional Garage Doors

**FR**

## **Notice de montage, d'utilisation, d'entretien et de démontage**

Porte sectionnelle de garage série 40

**ES**

## **Instrucciones para el montaje, funcionamiento, mantenimiento y desmontaje**

Puertas seccionales de garaje de la serie 40

**RU**

## **Руководство по монтажу, эксплуатации, техобслуживанию и демонтажу**

Секционные ворота для гаража строительной серии 40

**+**

**NL** NEDERLANDS

**IT** ITALIANO

**PT** PORTUGUÊS

**PL** POLSKI

**HU** MAGYAR

**CS** ČESKY

**SL** SLOVENSKO

**NO** NORSK

**SV** SVENSKA

**FI** SUOMI

**DA** DANSK

**SK** SLOVENSKY

**TR** TÜRKÇE

**LT** LIETUVIŲ KALBA

**ET** EESTI

**LV** LATVIEŠU VALODA

**HR** HRVATSKI

**SR** SRPSKI

**EL** ΕΛΛΗΝΙΚΑ

**RO** ROMÂNĂ

**BG** БЪЛГАРСКИ

DEUTSCH .....	3
ENGLISH .....	7
FRANÇAIS .....	11
ESPAÑOL .....	15
РУССКИЙ .....	19
NEDERLANDS .....	24
ITALIANO .....	28
PORTUGUÊS .....	32
POLSKI .....	36
MAGYAR .....	40
ČESKY .....	44
SLOVENSKO .....	48
NORSK .....	52
SVENSKA .....	56
SUOMI .....	60
DANSK .....	64
SLOVENSKY .....	68
TÜRKÇE .....	72
LIETUVIŲ KALBA .....	76
EESTI .....	80
LATVIEŠU VALODA .....	84
HRVATSKI .....	88
SRPSKI .....	92
ΕΛΛΗΝΙΚΑ .....	96
ROMÂNĂ .....	100
БЪЛГАРСКИ .....	104



.....	108
-------	-----

**Contents**

**1 About These Instructions.....7**

1.1 Warnings used.....7

**2 ⚠ Safety Instructions.....7**

2.1 Intended use.....7

2.2 General safety instructions.....7

2.3 Environmental conditions .....8

**3 Fitting.....8**

3.1 Tensioning the springs.....8

**4 Operation.....8**

4.1 Operating the door .....8

4.2 Locking and unlocking .....9

**5 Cleaning and Care .....9**

**6 Inspection and Maintenance .....9**

6.1 Inspections and maintenance .....9

**7 Malfunctions and Troubleshooting .....10**

7.1 Paint treatment.....10

**8 Dismantling .....10**

 .....108

Dear Customer,

we are delighted that you have chosen a quality product from our company.

**1 About These Instructions**

These instructions are divided into a text section and an illustrated section. The illustrated section can be found after the text section.

These instructions are **original instructions** as outlined in the EC Directive 2006/42/EC. Read and follow these instructions carefully. They contain important information concerning the product. Please pay particular attention to all safety and warning notices.

**Keep these instructions in a safe place for later reference!**

**1.1 Warnings used**



The general warning symbol indicates a danger that can lead to **injury** or **death**. In the text, the general warning symbol will be used in connection with the caution levels described below. In the illustrated section, an additional instruction refers back to the explanation in the text.

**⚠ WARNING**

Indicates a danger that can lead to death or serious injuries.

**ATTENTION**

Indicates a danger that can lead to **damage** or **destruction** of the product.

**2 ⚠ Safety Instructions**

**2.1 Intended use**

This garage door is designed and intended for private use only.

Continuous operation is not permitted.

**2.2 General safety instructions**

- Fitting, maintenance, repair and dismantling of the Series 40 sectional garage door may only be carried out by specialists (competent persons in accordance with EN 12635).
- In the event of a door failure (sluggish operation or other malfunctions), a specialist must be commissioned immediately for the inspection/repair work.
- The specialist must ensure that the respective national regulations regarding occupational safety are complied with.
- Before the door is put into service, it must be tested to make sure that it is mechanically sound, in perfect working order as well as correctly balanced, making it also easy to operate manually (EN 12604).
- The field of application for Series 40 sectional doors is laid down in EN 13241-1.

Dissemination as well as duplication of this document and the use and communication of its content are prohibited unless explicitly permitted. Noncompliance will result in damage compensation obligations. All rights reserved in the event of patent, utility model or design model registration. Subject to changes.

- When the door is fitted, attention must be paid to potential hazards as defined in EN 12604 and EN 12453.

**2.3 Environmental conditions**

<b>ATTENTION</b>
<p><b>Damage due to temperature differences</b></p> <p>Differences in the inside and outside temperatures may cause deflection of the door elements (bi-metal effect). This may result in damage when the door is operated.</p> <ul style="list-style-type: none"> <li>▶ Comply with the operating conditions.</li> </ul>

The door is intended for the following operating conditions:

Temperature:

- Exterior side -40°C to +60°C
- Interior side -20°C to +60°C

Relative humidity: 20% to 90%

**3 Fitting**

<b>⚠ WARNING</b>
<p><b>Danger of injury as the result of structural modifications</b></p> <p>Changing or removing functional parts may put important safety components out of action. Uncontrolled door travel could occur and persons or objects may be trapped as a result.</p> <ul style="list-style-type: none"> <li>▶ Do not alter or remove any functional parts.</li> <li>▶ Do not attach any additional components. The torsion springs are precisely matched to the door leaf weight. Additional components may overload the springs.</li> <li>▶ If equipping the door with an operator, pay attention to the instructions provided by the manufacturers of the door and operator. Only use the original connections of the door manufacturer!</li> </ul>

Before fitting the door, the door opening and the building floor must be completely finished.

Observe the following during fitting:

- Establish a secure connection with the building structure.
- Check that the fixing materials supplied are suitable for the given structural conditions.
- Do not fasten the door system to supporting structural members unless you have obtained the prior approval of the structural engineer.
- Ensure adequate water run-off in the area of the bottom seal and the frame parts, otherwise there is danger of corrosion (see Technical Manual).
- Ensure sufficient drying and ventilation in the building, otherwise there is danger of corrosion.
- The door must be effectively protected before carrying out plastering and paintwork, as splashes of mortar, cement, plaster, paint etc. can damage the door surface.
- Protect the door from caustic, aggressive substances, e.g. nitrous reactions from stones or mortar, acids, alkali solutions, de-icing salt, aggressive paints or sealants. Failure to do so could lead to corrosion.

- ▶ **To ensure simple and secure fitting, please follow the work steps listed in the illustrated section.**

**3.1 Tensioning the springs**

<b>⚠ WARNING</b>
<p><b>Danger of injury due to high torques</b></p> <p>Springs are under high torque stress and may discharge high forces if they are not secured during tensioning.</p> <ul style="list-style-type: none"> <li>▶ Fix the door leaf to prevent movement before tensioning the springs.</li> </ul>

The number of tensioning revolutions specified on the type plate is an approximate value only.

When the springs are tensioned correctly, the moving door leaf has a slight tendency to pull upwards.

- ▶ Each time the door is serviced, the tension of the springs should be checked and, if necessary, subsequently re-adjusted.
- ▶ **Before putting the door into operation for the first time, inspect the door according to the chapter *Inspection and Maintenance!***

**4 Operation**

**4.1 Operating the door**

<b>⚠ WARNING</b>
<p><b>Danger of injury during door travel</b></p> <p>The sectional door closes to the bottom vertically; persons or objects may be trapped.</p> <ul style="list-style-type: none"> <li>▶ When in operation, make sure that neither persons, children in particular, nor objects are located within the door's area of travel.</li> <li>▶ Always keep the opening area of the door clear.</li> <li>▶ Do not operate the door in strong winds.</li> </ul>

The door must only be operated by **suitably instructed** persons. If the sectional door is competently fitted and inspected, it can be easily moved and operated.

**4.1.1 Manually operated doors**

<b>⚠ WARNING</b>
<p><b>Danger of injury due to improper operation</b></p> <p>Persons or objects may be trapped if the door is operated improperly.</p> <ul style="list-style-type: none"> <li>▶ Only open and close the door using the supplied operating elements; these ensure a controlled, smooth action.</li> <li>▶ When closing the door, make sure that the latches engage fully and correctly.</li> </ul>

**4.1.2 Power-driven doors**

The automation of a sectional door requires that special safety regulations be observed. Consult your supplier.

## 4.2 Locking and unlocking

The door is not locked when closed with the grip handle. This is done by using the key or locking lever on the lock.

### From outside:

- ▶ Turn the key 360°
  - To unlock: turn the key left
  - To lock: turn the key right

### From inside:

- ▶ Slide the locking lever on the lock
  - To unlock: slide it upwards
  - To lock: slide it downwards

## 5 Cleaning and Care

### ATTENTION

#### Scratches on the panes due to improper cleaning

Rubbing the panes causes scratches.

- ▶ Dirt and dust particles must first be thoroughly rinsed off with water. If necessary, only wash with water, a pH-neutral household detergent and a soft, clean cloth.

**Clear water is sufficient for cleaning and care.** Use warm water together with a neutral, non-abrasive cleaning agent (household detergent, pH value 7) if more heavily soiled. To preserve the surface characteristics, **regular cleaning must be carried out at least every 3 months** (outside of door, seals). The slide area behind the side seals must be kept permanently clean and able to slide.

A variety of environmental influences (e.g. maritime climate, acids, road salt, air pollutants, paint damage) may make additional protective coating necessary (see *Paint treatment* on page 10).

## 6 Inspection and Maintenance

### 6.1 Inspections and maintenance

#### ⚠ WARNING

#### Danger of injury due to defective safety components

Important safety components may fail or become defective if not sufficiently inspected and maintained.

- ▶ Have a qualified person perform inspection and maintenance work at regular intervals.

The following inspection and maintenance tasks must be carried out by a specialist in accordance with these instructions, before initial operation and at least once a year (or every 6 months if there are more than 50 door cycles per day).

### 6.1.1 Inspect all load-bearing components

#### ⚠ WARNING

#### Danger of injury due to high cable tension and high torques

Cables and springs are under high tension and torques. Damaged cables or springs may also cause serious injuries.

- ▶ Fix the door leaf to prevent uncontrolled movement before exchanging damaged cables or springs.
- ▶ Be particularly careful when exchanging damaged cables or springs.

- ▶ Check load carriers (cables, springs, tracks, supports) and safety devices for breakage and damage, replacing any damaged components as necessary.

#### Spring safety device

- ▶ Check the effectiveness of the detent pawl and the secure seat of the locking gear (see Fig. 14.3 Spring safety device).

### 6.1.2 Weight counterbalance

#### ⚠ WARNING

#### Danger of injury due to uncontrolled door drops

If the counterbalance has not been properly adjusted, this may result in an uncontrolled door drop, which could trap persons or objects.

- ▶ Retension the torsion springs.

#### High torque

Springs are under high torque stress and may discharge high forces if they are not secured during tensioning.

- ▶ Fix the door leaf to prevent uncontrolled movement before adjusting the torsion spring shaft.

#### Check the counterbalance of the door leaf

- ▶ Manually open the door halfway. The door should be able to hold this position.

#### If the door moves substantially downwards:

- ▶ Retension the torsion springs.

### 6.1.3 Fixing points

- ▶ Check all the fixing points on the door and the building structure and make sure that all the fastenings are securely seated and, if necessary, retighten.

### 6.1.4 Rollers and tracks

When the door is closed, the rollers must be easy to turn.

- ▶ Adjust rollers if necessary. Observe the operator fitting notes; they contain details on roller adjustment.
- ▶ Clean tracks, if necessary, **do not grease!**

### 6.1.5 Hinges and roller holders

- ▶ Oil hinges and roller holders.

### 6.1.6 Locking cylinders

<b>ATTENTION</b>
<p><b>Damage to the locking cylinders due to unsuitable cleaning products</b></p> <p>Locking cylinders may not be cleaned with agents containing oil or be oiled.</p> <ul style="list-style-type: none"> <li>▶ Only use specialised care products.</li> <li>▶ Do not use oil or graphite.</li> </ul>

### 6.1.7 Seals

- ▶ Check for damage, deformations and completeness. If necessary, replace.

## 7 Malfunctions and Troubleshooting

 <b>WARNING</b>
<p><b>Danger of injury due to uncontrolled door movement</b></p> <p>If the door malfunctions, uncontrolled door movements may trap persons or objects.</p> <ul style="list-style-type: none"> <li>▶ In the event of a door failure (sluggish operation or other malfunctions), a specialist must be commissioned immediately for the inspection/repair work.</li> </ul>

Once the spring safety device has been activated, the door leaf weight is no longer balanced. Further operation of the door is no longer possible.

### Spring safety device

1. Once the spring safety device has been activated, hold the door leaf using a suitable auxiliary tool, then move the spring shaft with a tensioning spindle so that the capture pawl can be released and secured with the security pin.
2. Afterwards, let the door leaf down, release the springs and replace the one that has broken.

### 7.1 Paint treatment

The door leaf is provided with a polyester-primer coating. If you want to paint the door a different colour, or if a renovation coating or additional protective coating is necessary:

- Lightly sand the surface with fine sand paper (at least 180 grain size).
- Clean with water, dry and remove any grease
- Treat further with commercially available synthetic resin paints suitable for outdoor applications.

Avoid dark coatings on double-skinned doors and doors with thermal breaks.

Follow the directions of the paint manufacturer!

### 7.1.1 Door with timber infill

Refer to the section on "advice for treating wooden doors" on how to apply paint treatment to doors with timber infills.

## 8 Dismantling

Dismantle the door in accordance with these fitting instructions, in the logically correct reverse order.

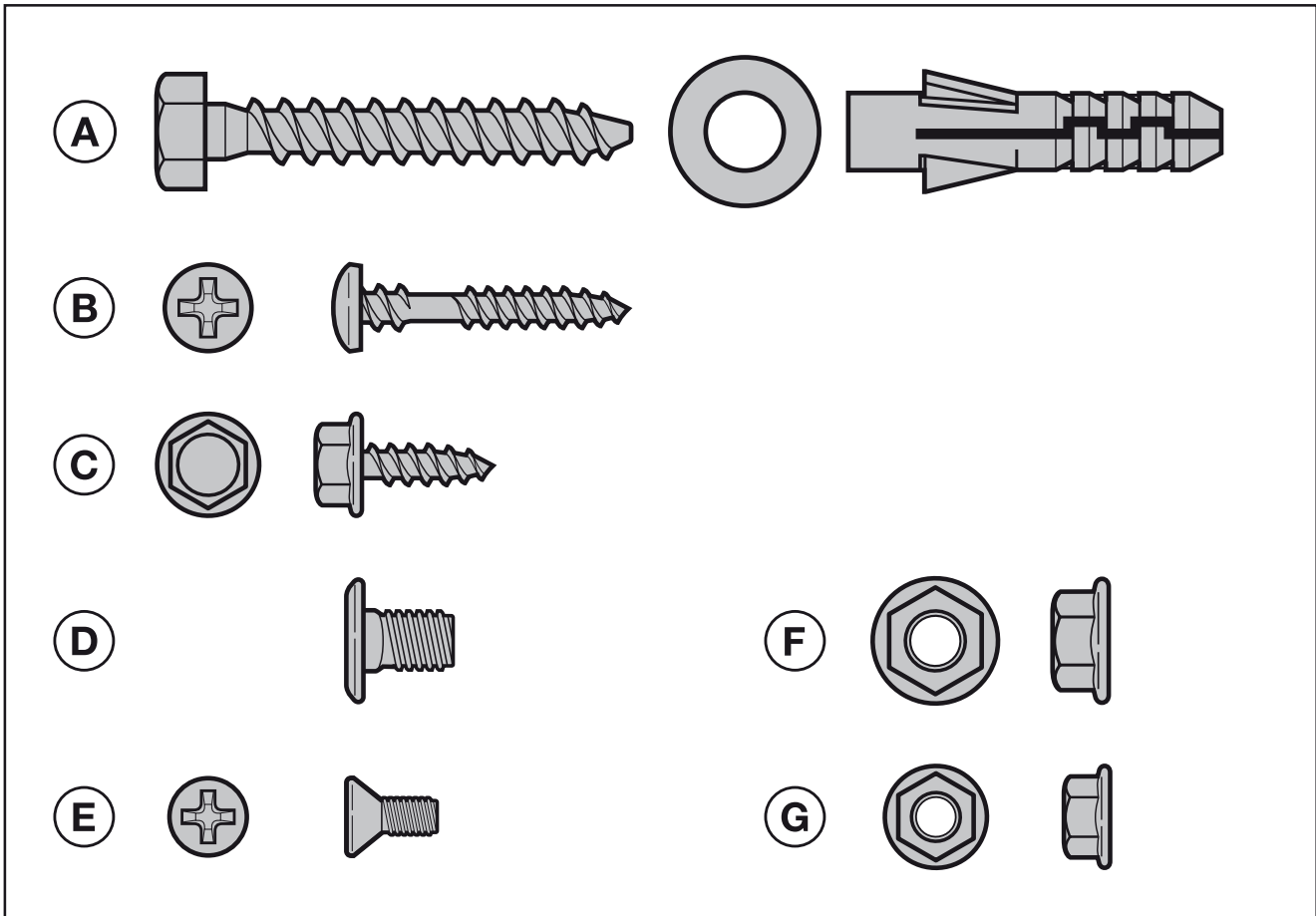
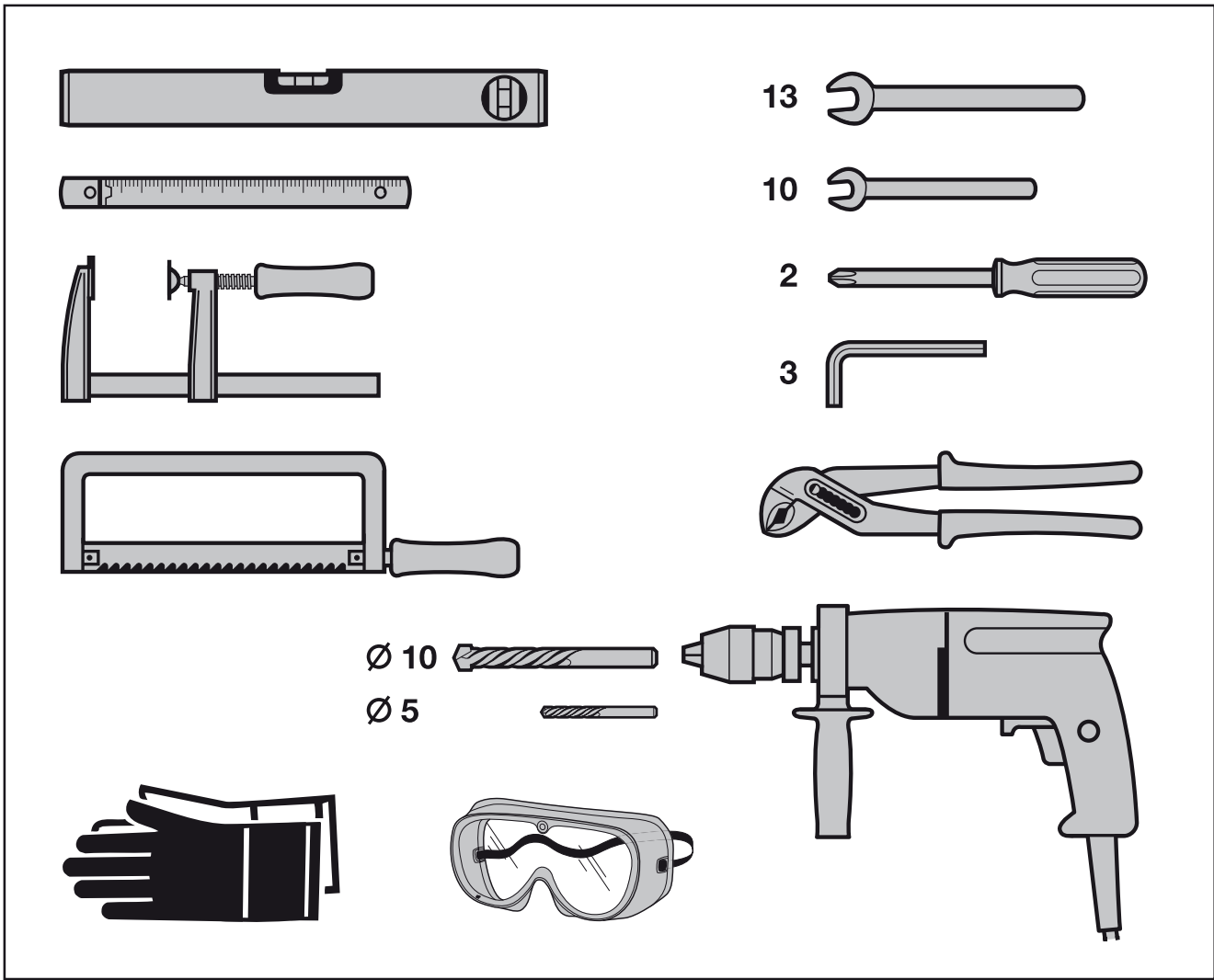

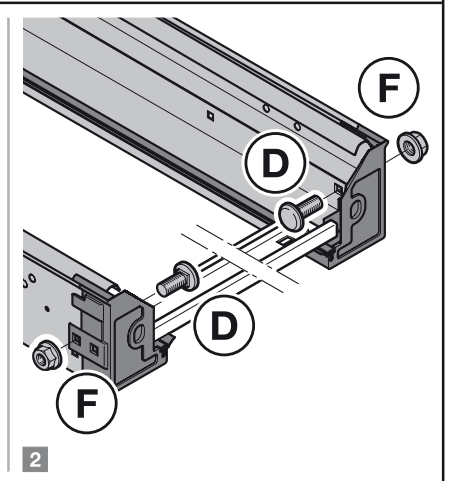
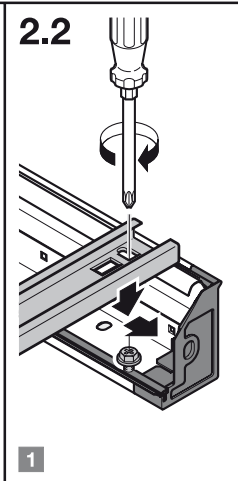
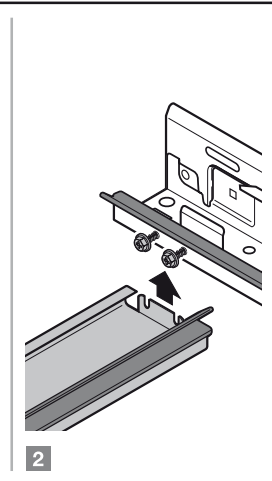
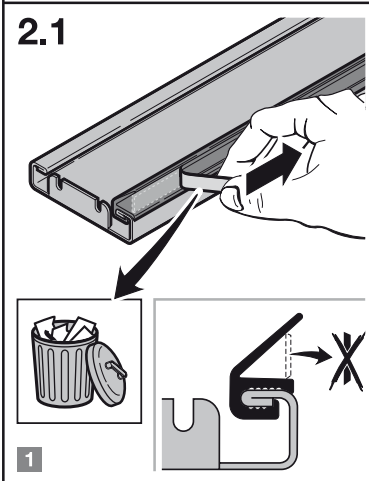
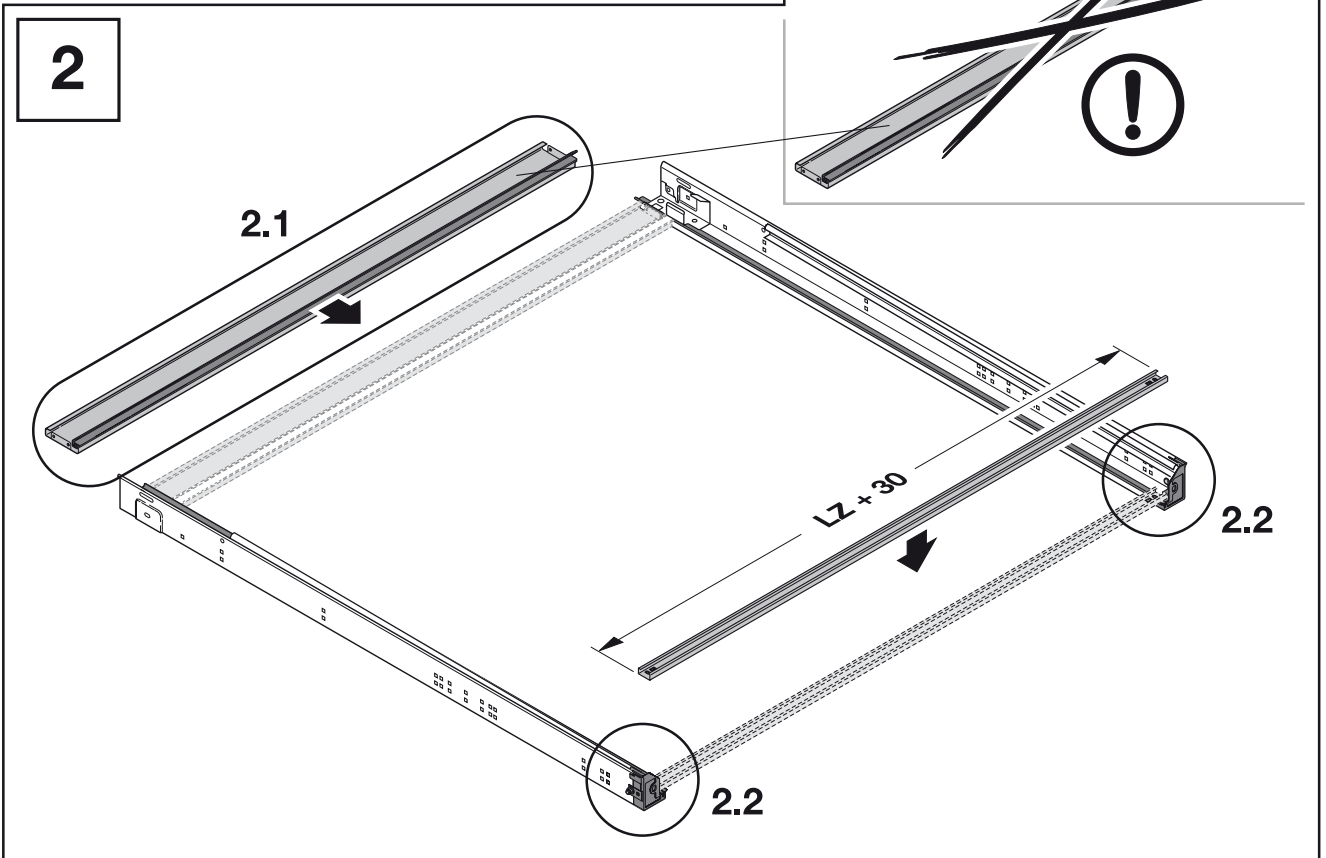
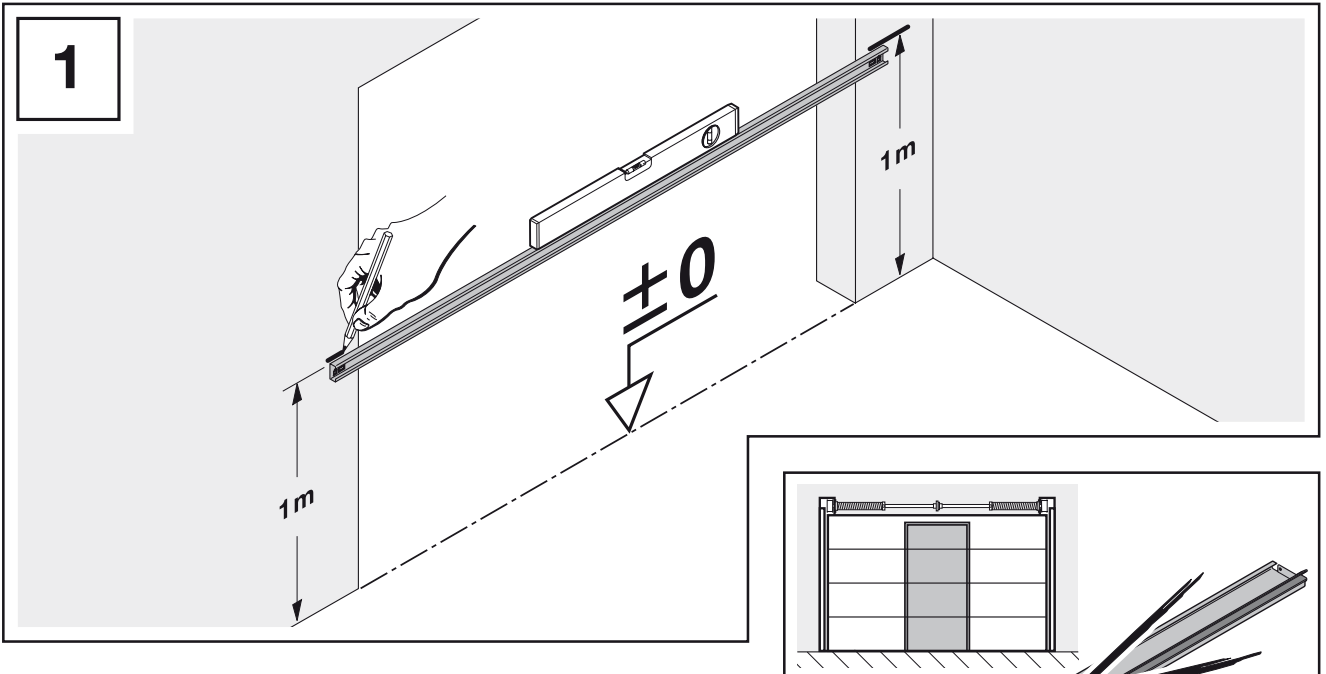



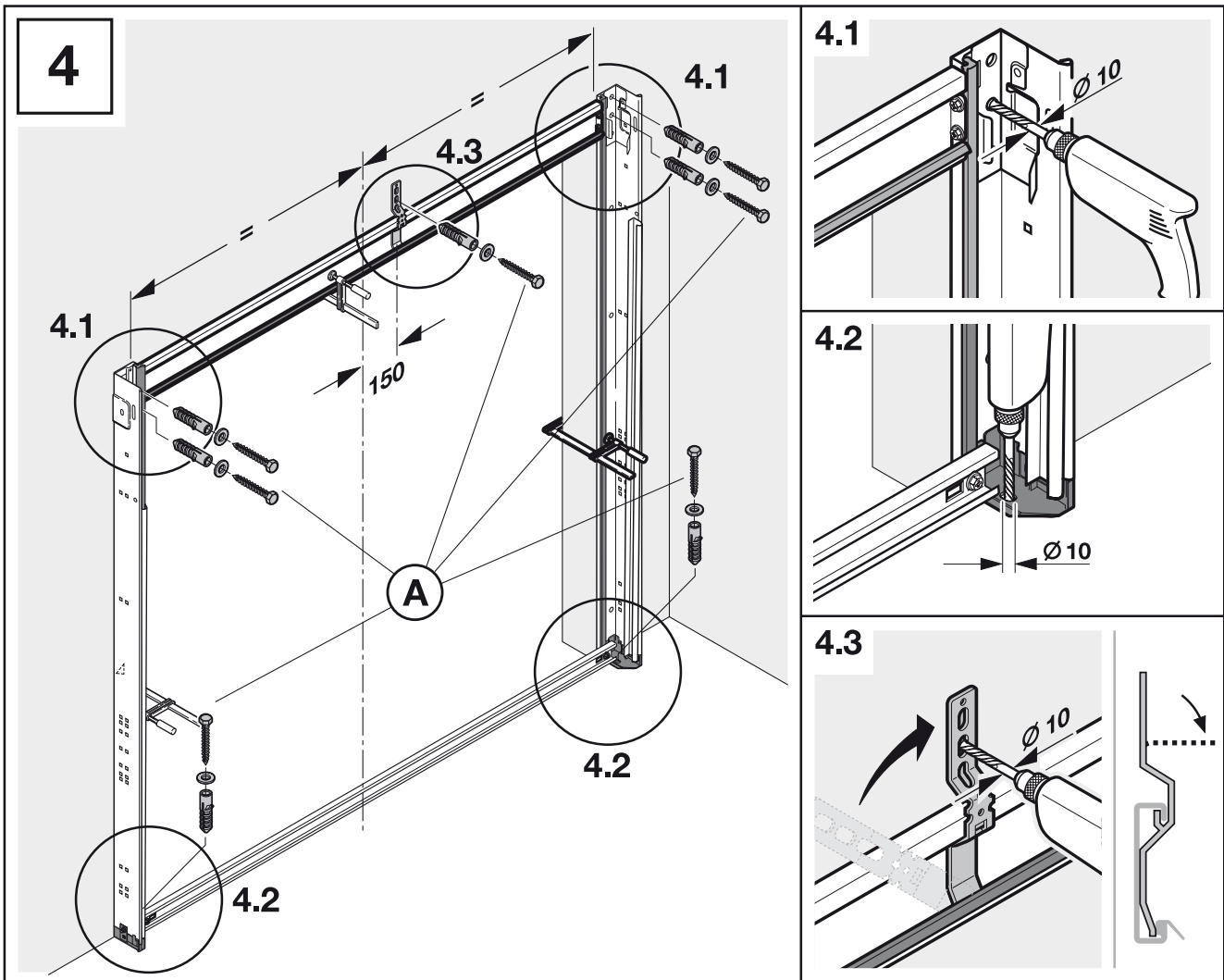
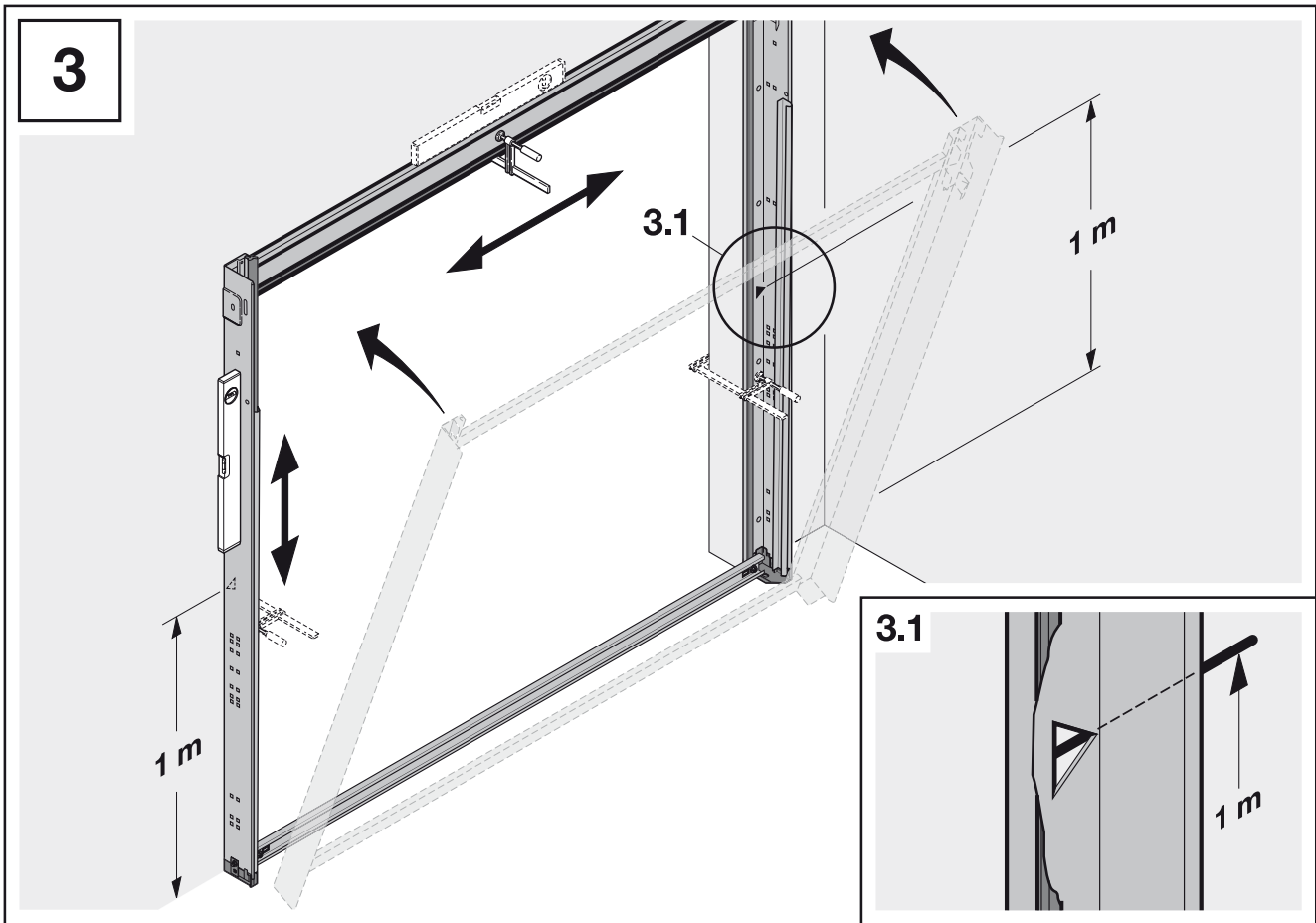

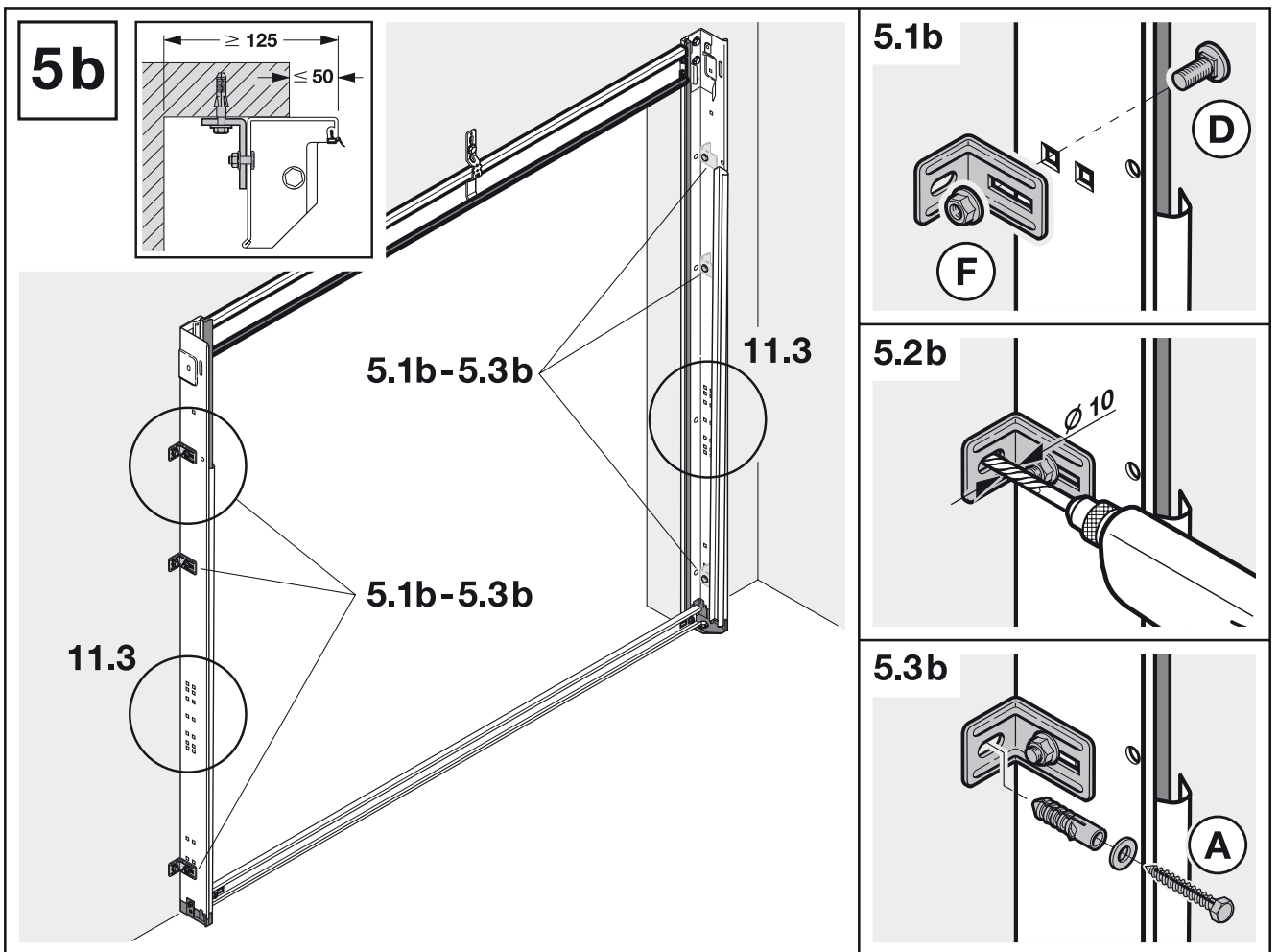
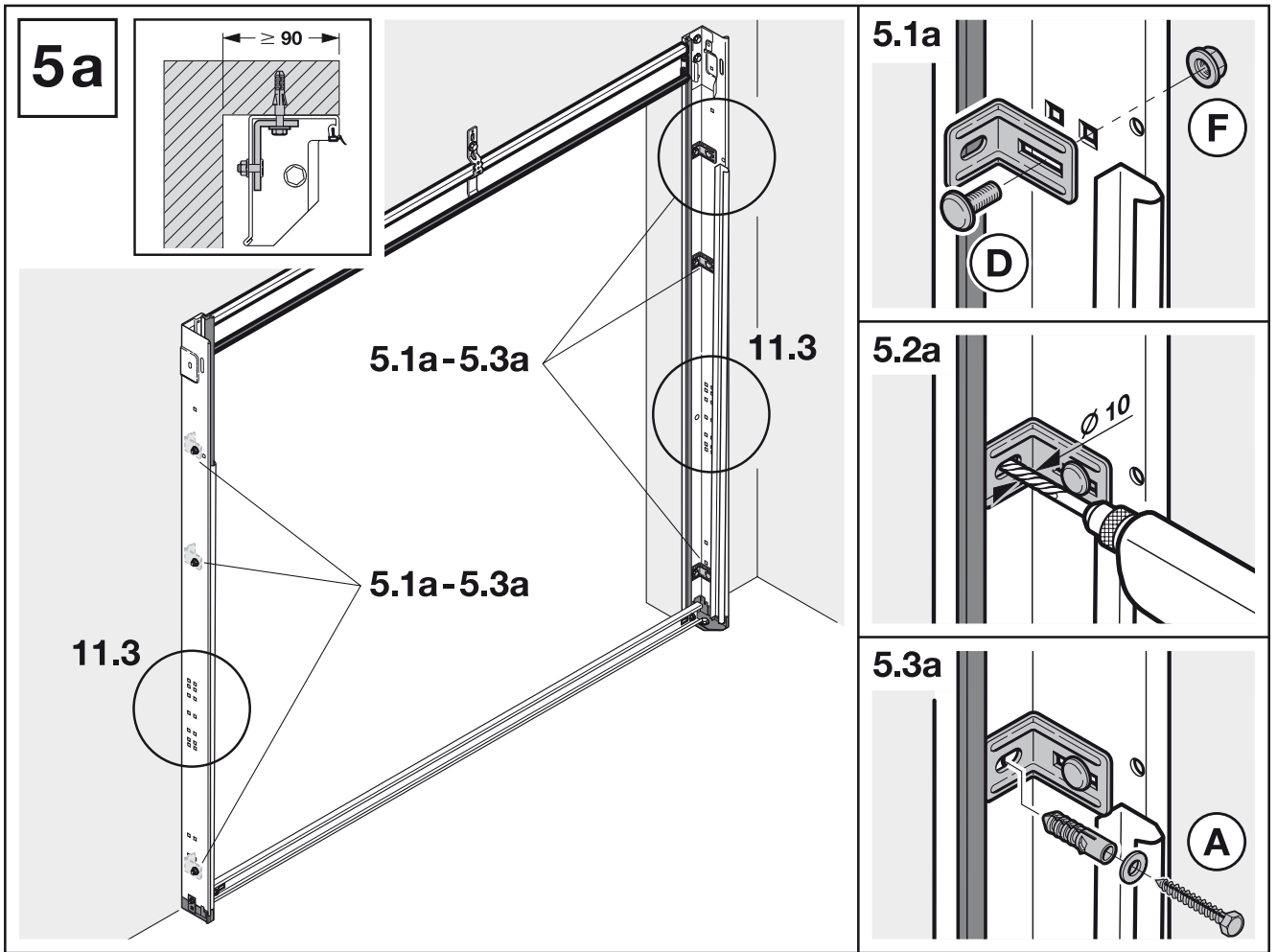

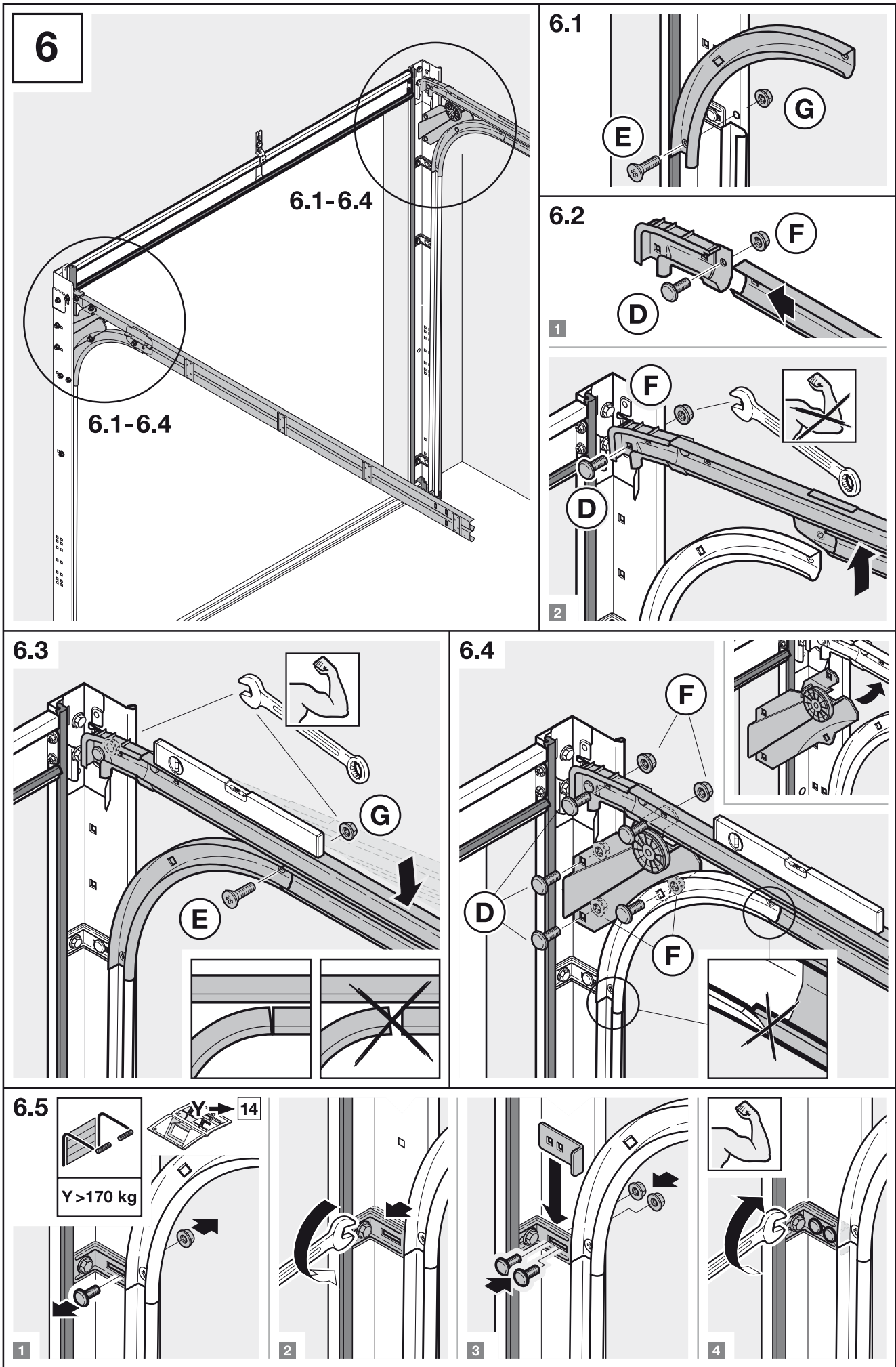

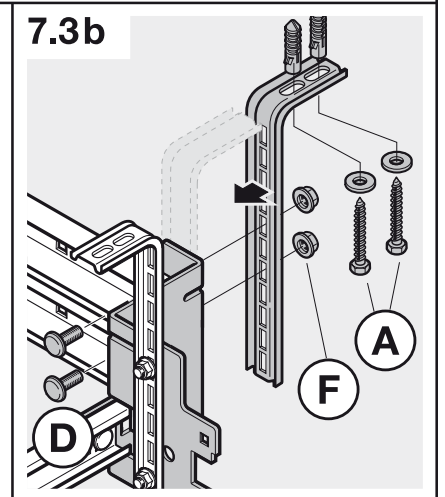
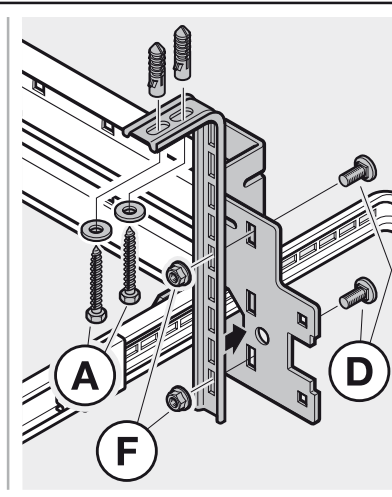
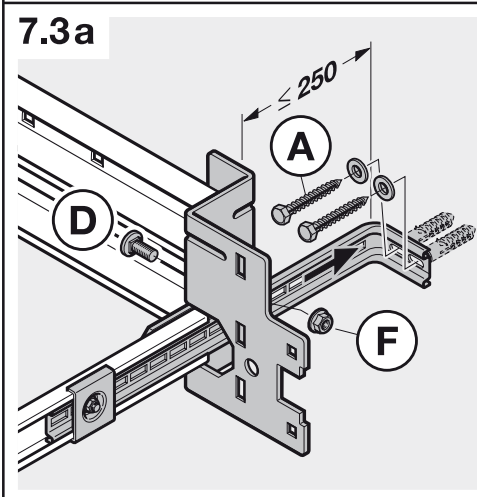
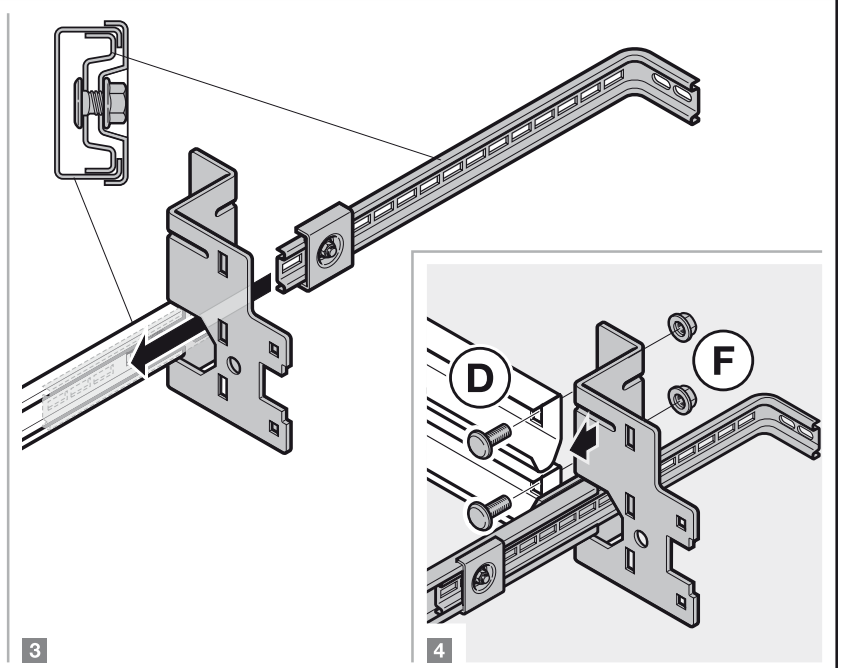
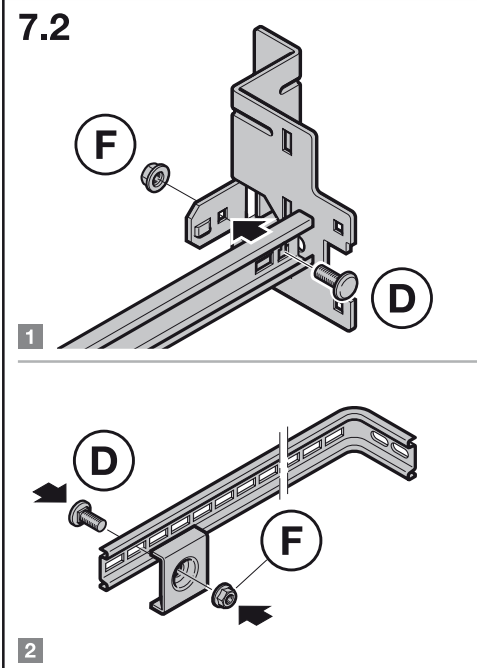
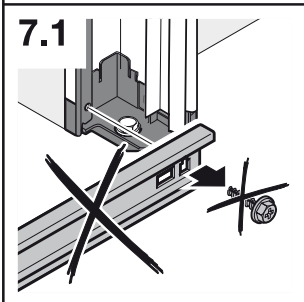
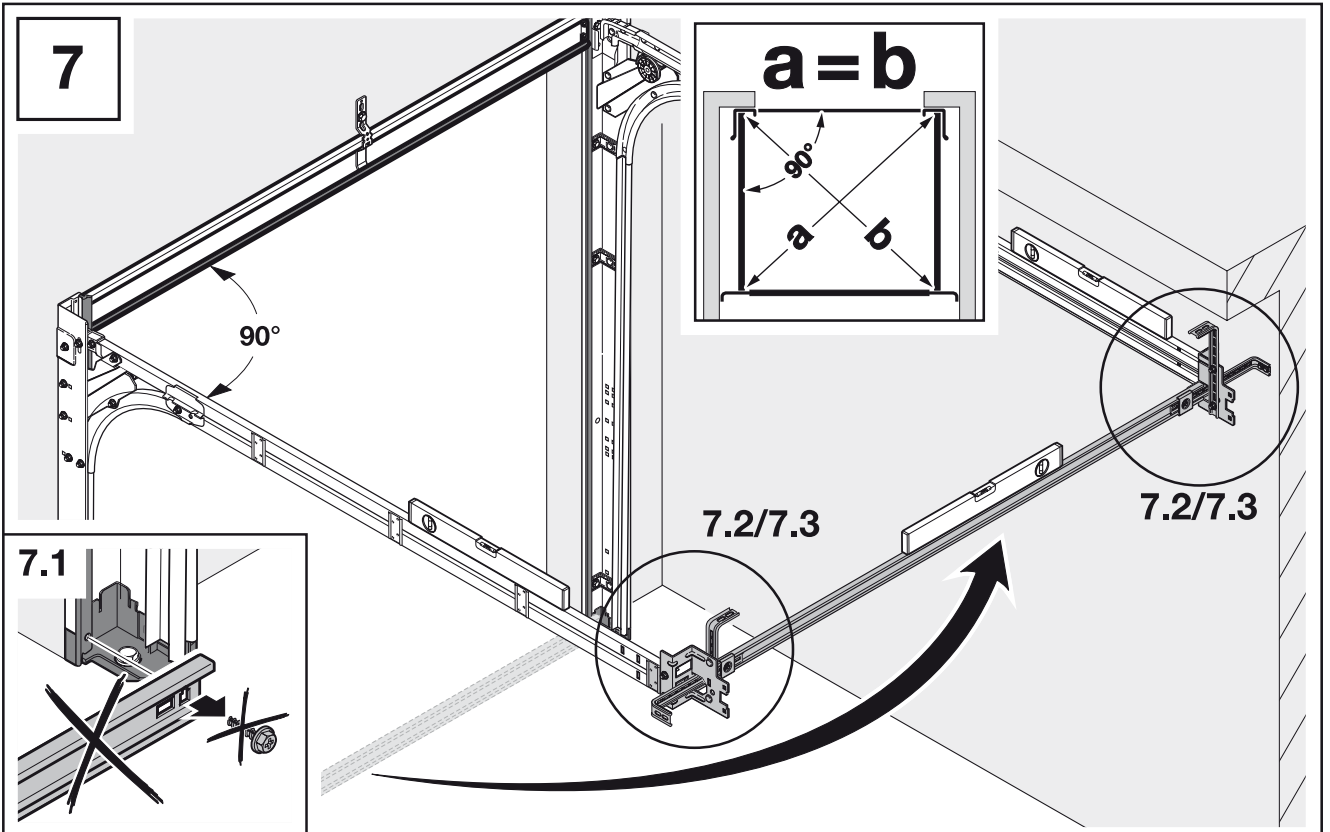

8

8.1-8.3

8.1-8.3

~1000 mm

8.1

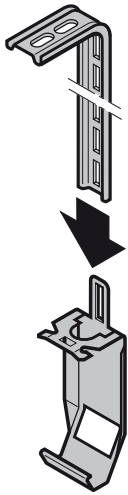

8.2

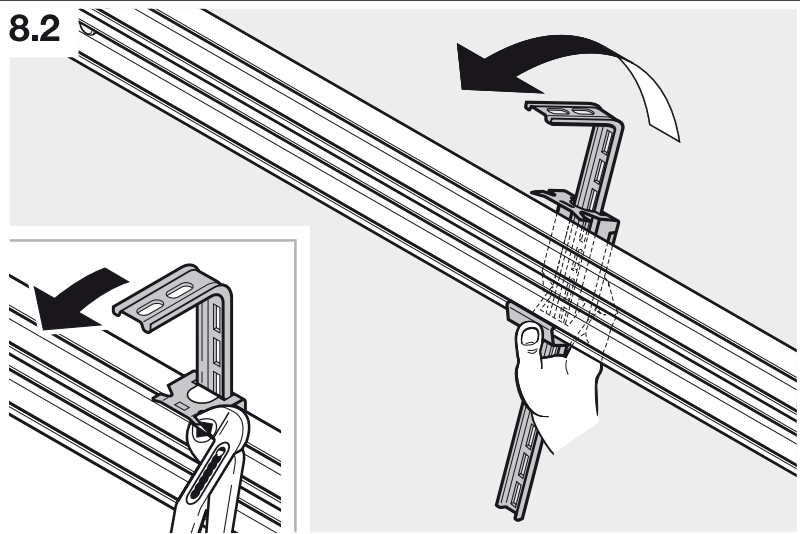

8.3a

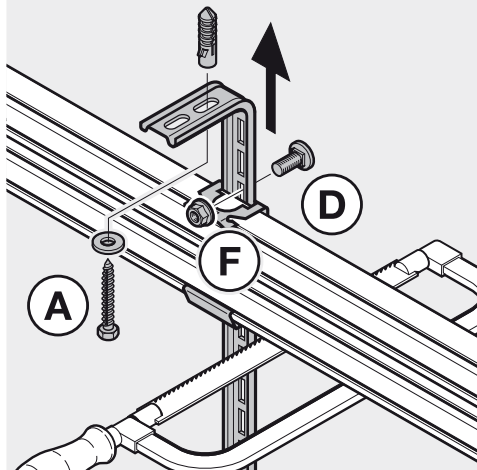

8.3b

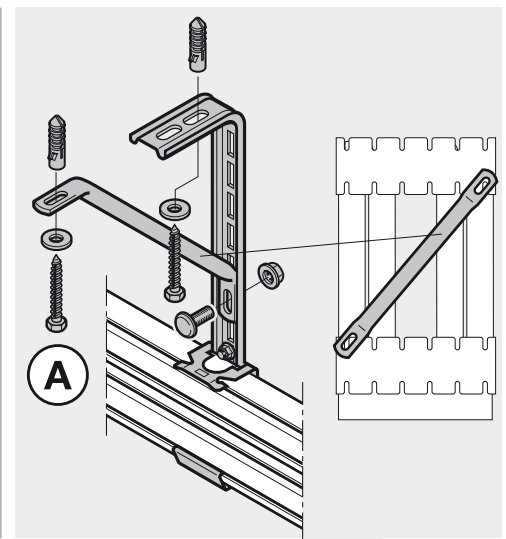
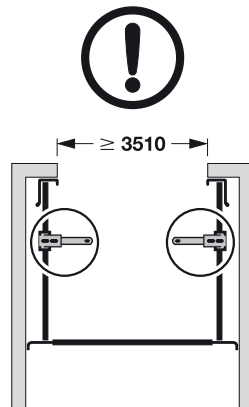

9

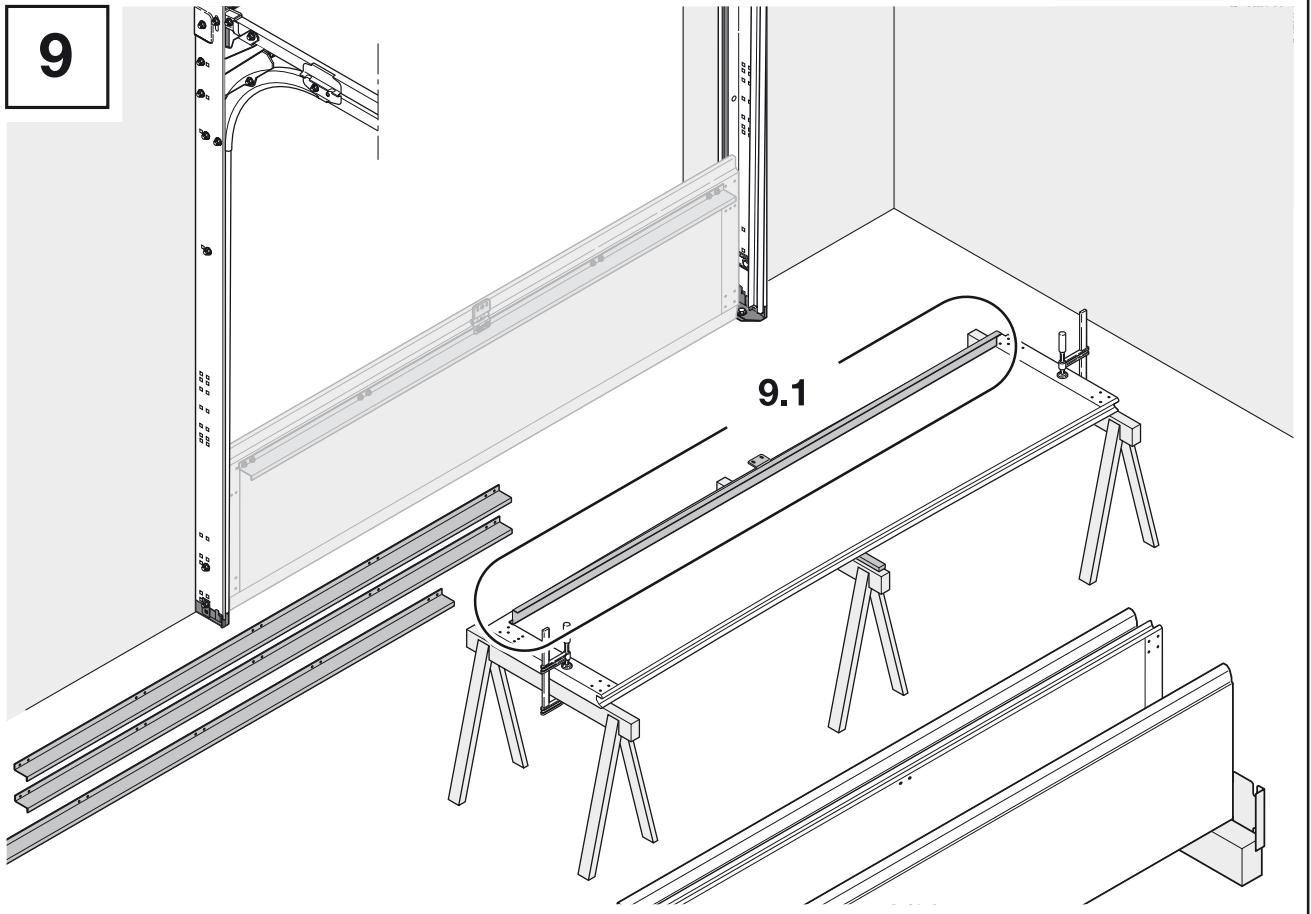

9.1a

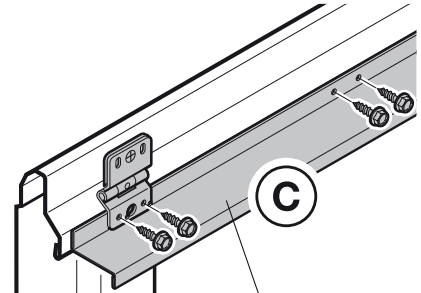
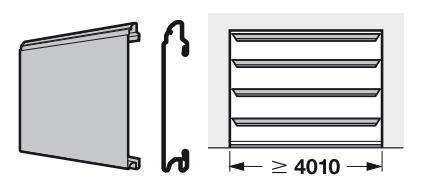
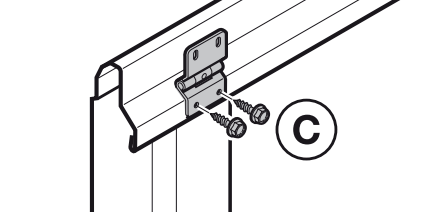

9.1b

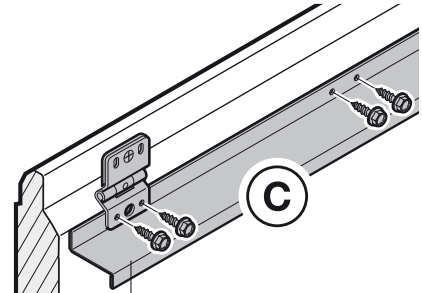
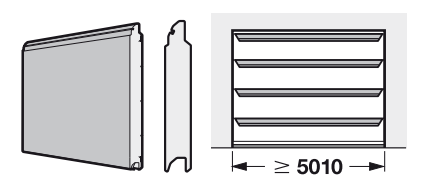
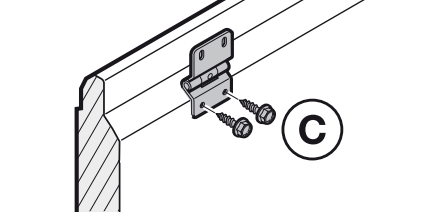

9.1c

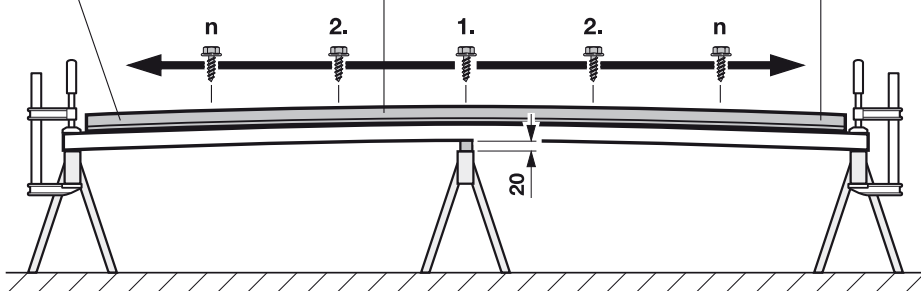
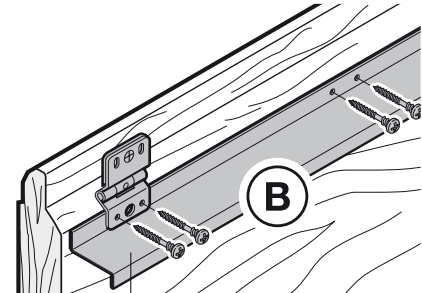
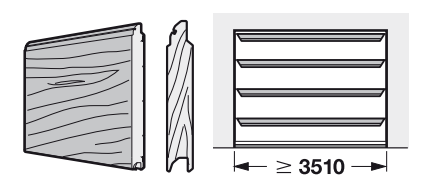
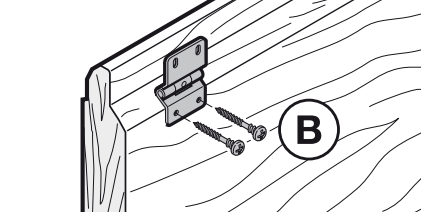

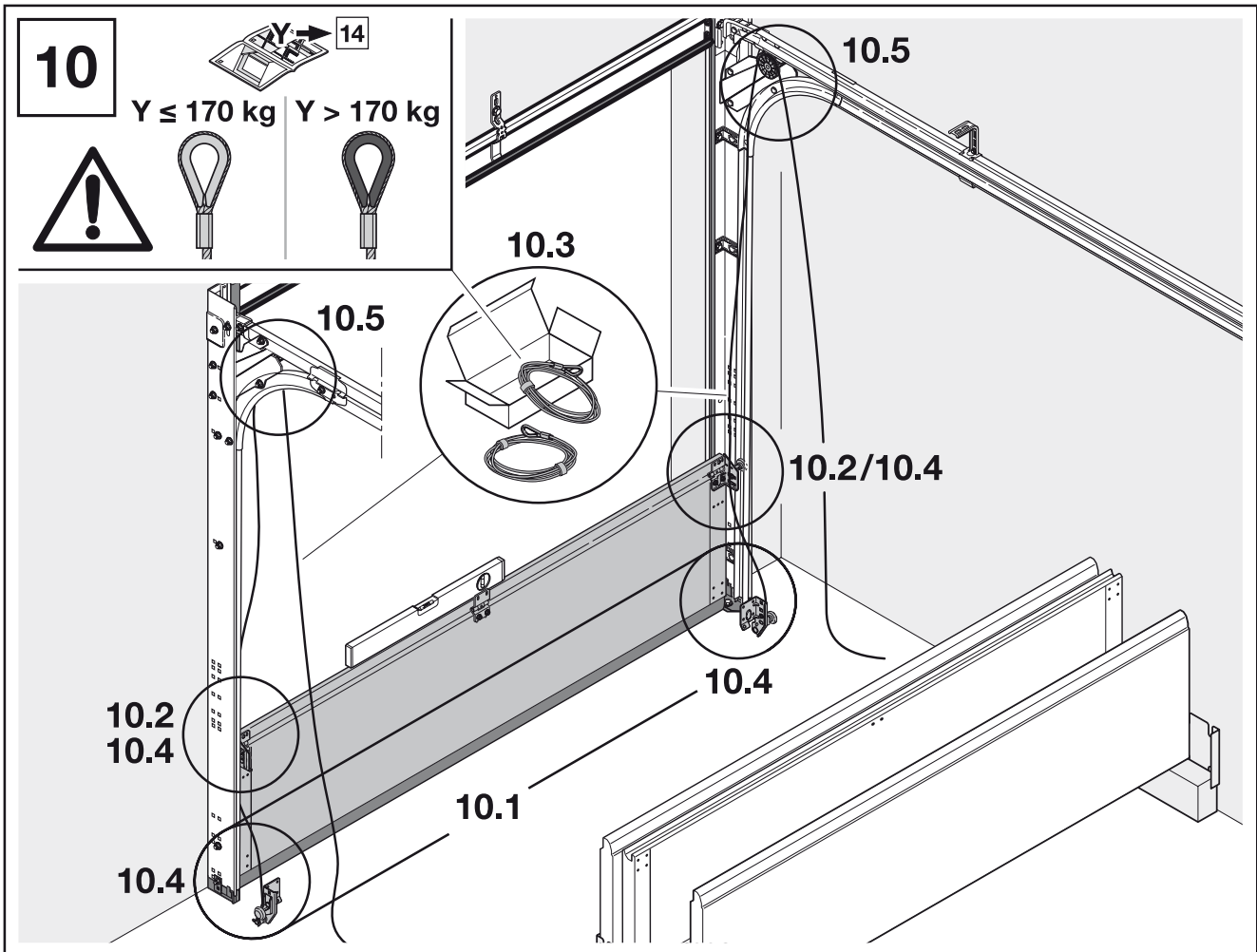

**10.1a**

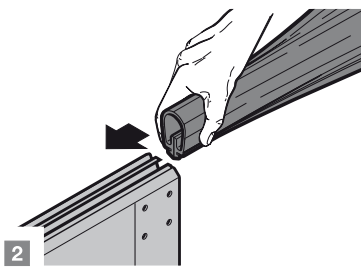
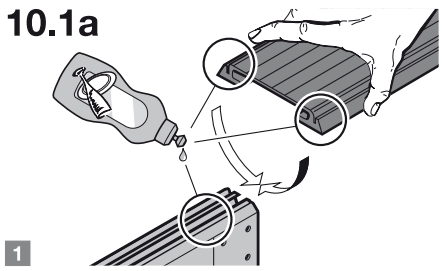

**10.2 LZ < 5010**

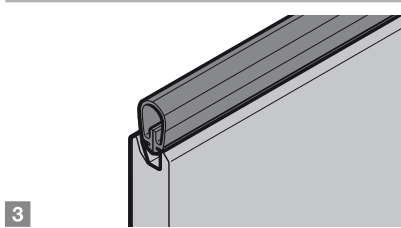
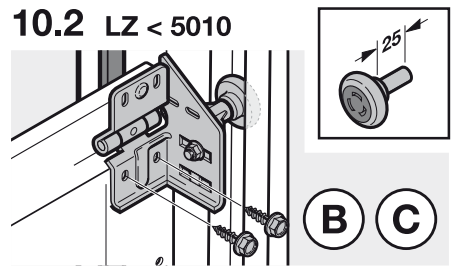

**10.1b**

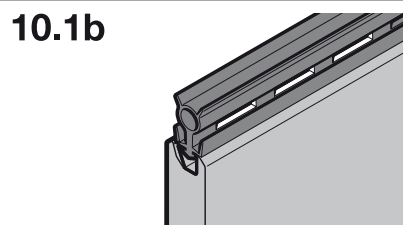

**LZ ≥ 5010**

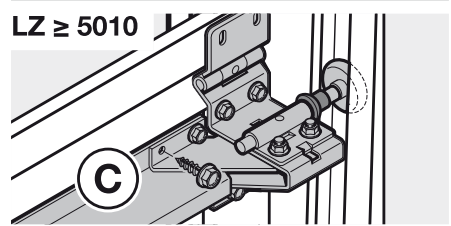

**10.3**

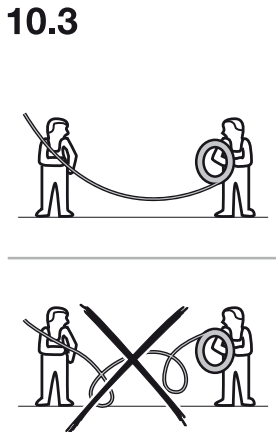

**10.4**

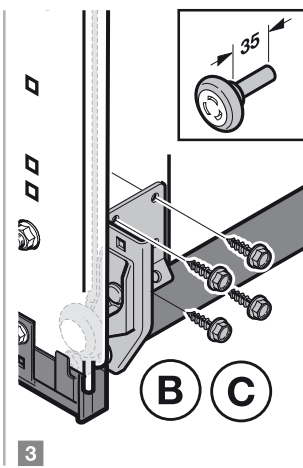
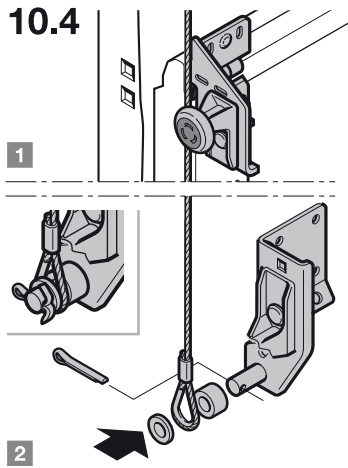

**10.5**

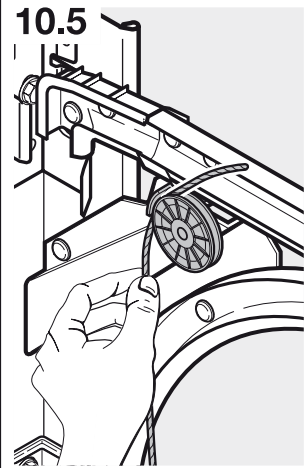

11

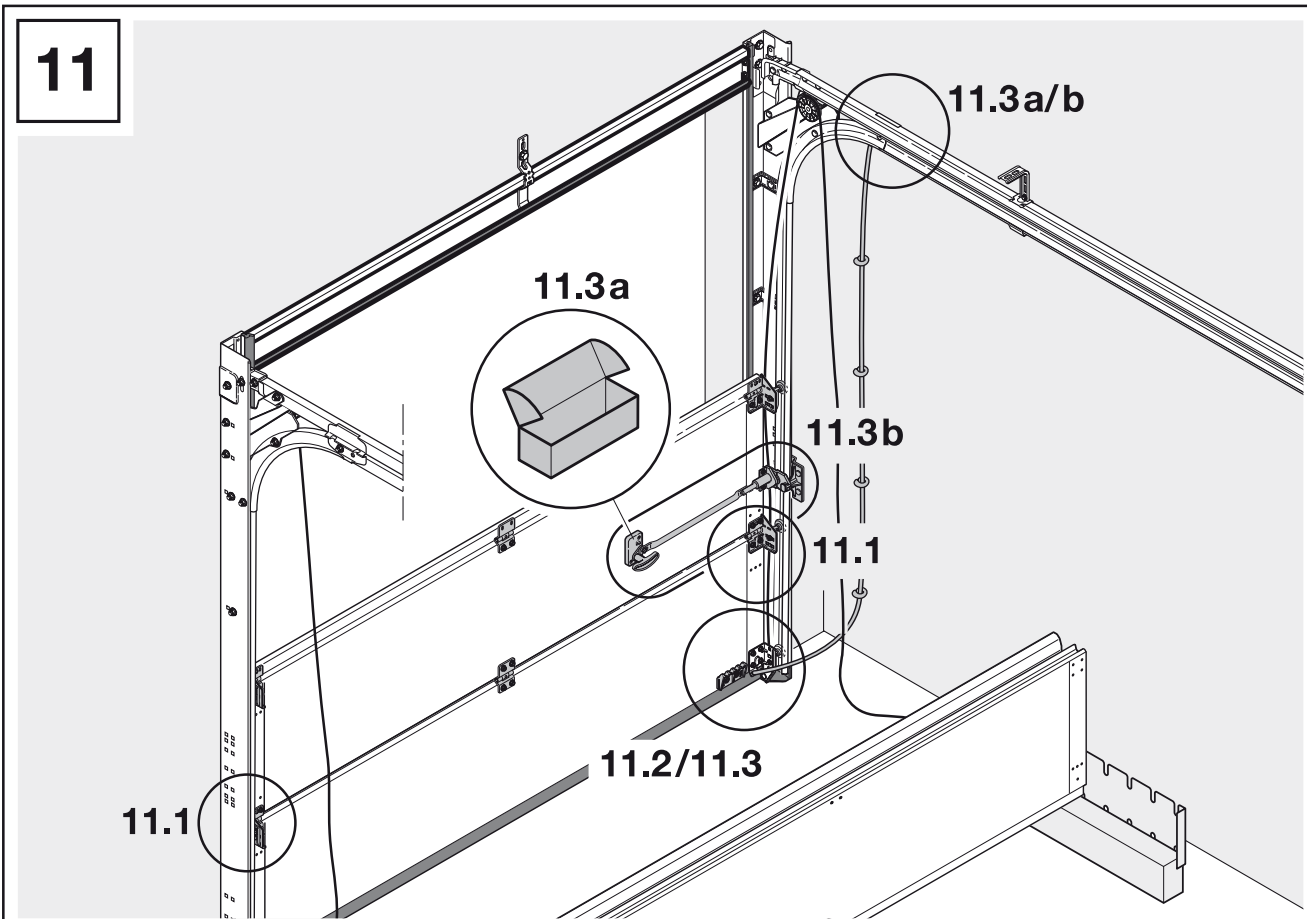

11.1

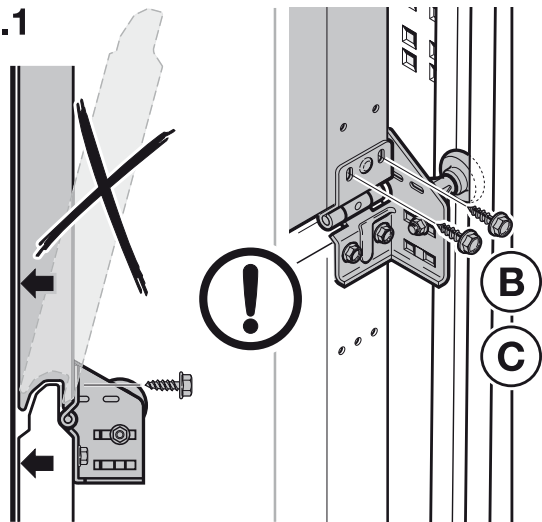

11.3a

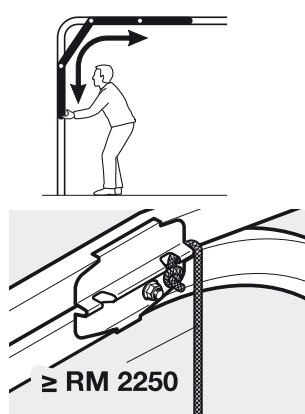

11.3b



11.2a

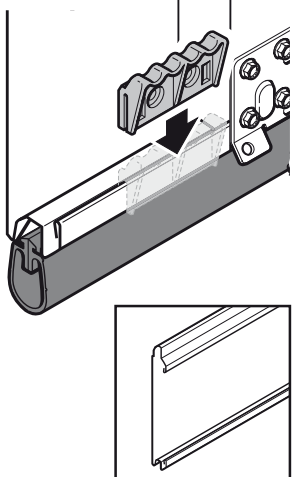

11.2b

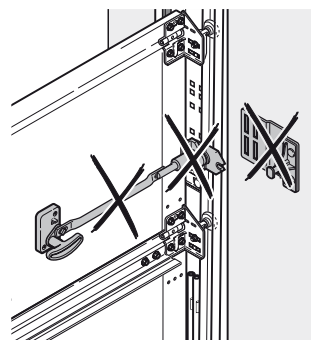
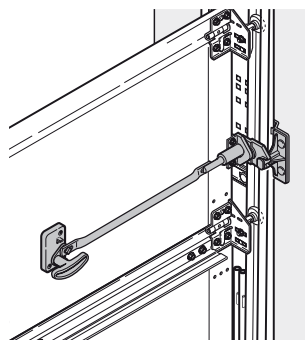
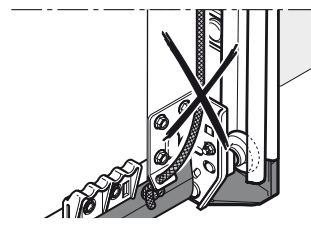
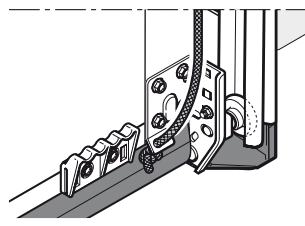
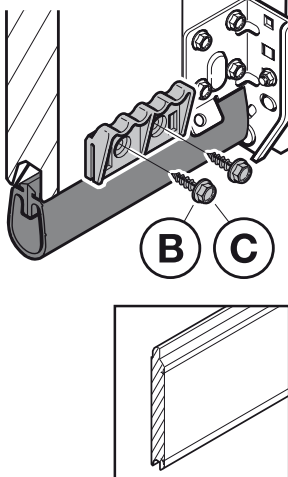



12

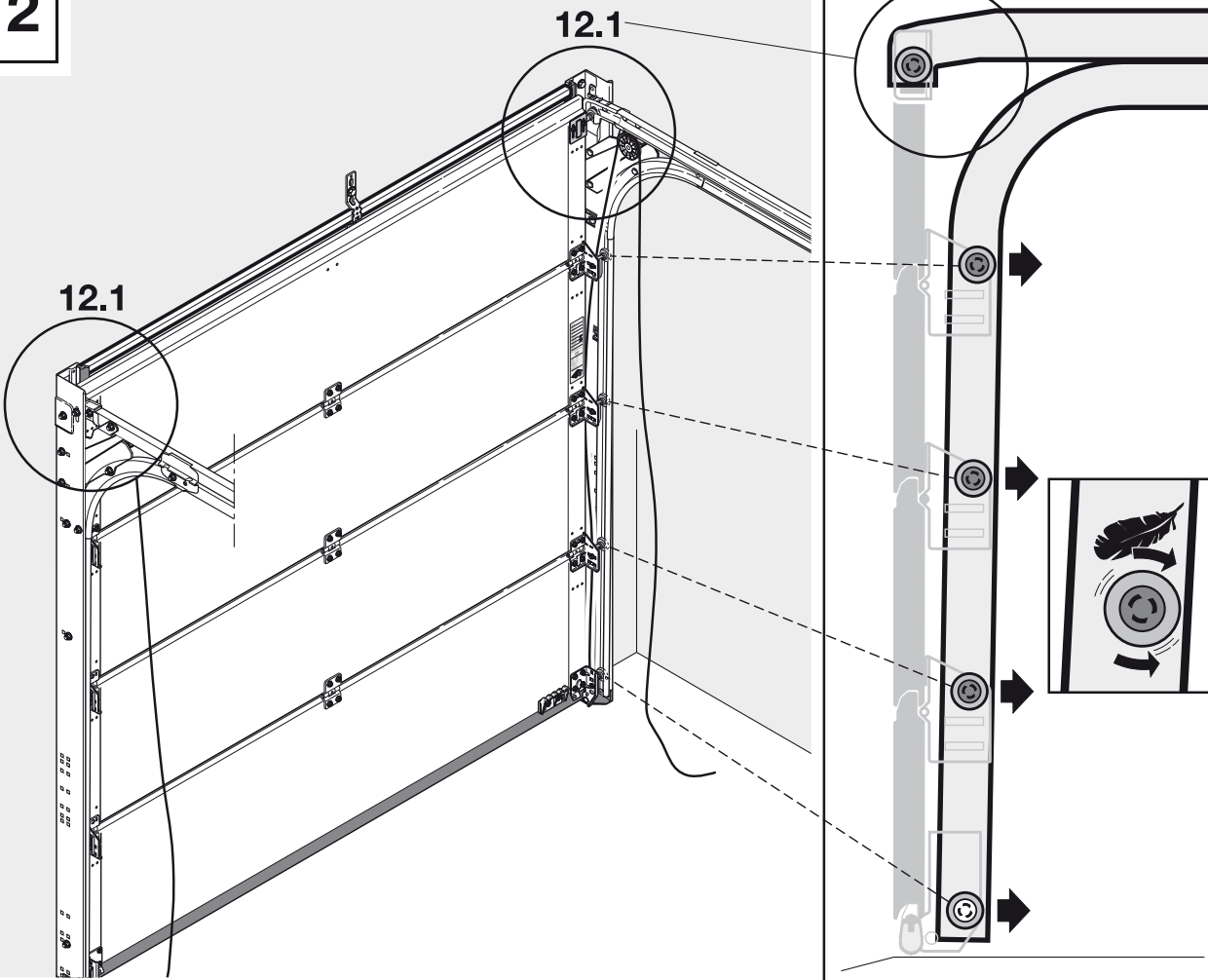

12.1a

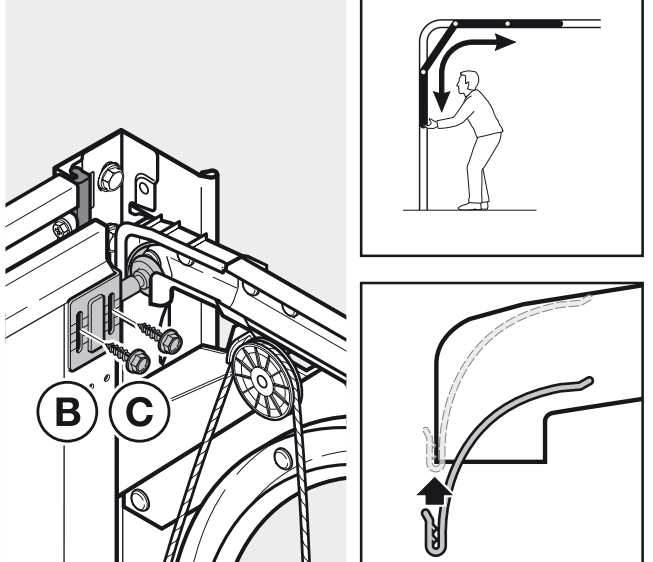

12.1b

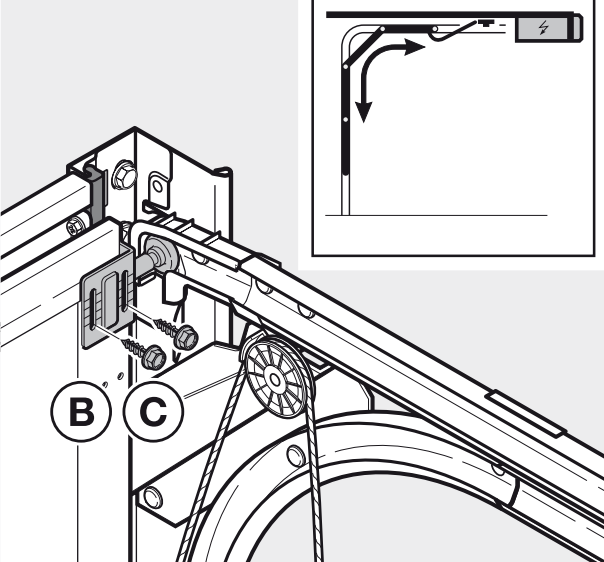

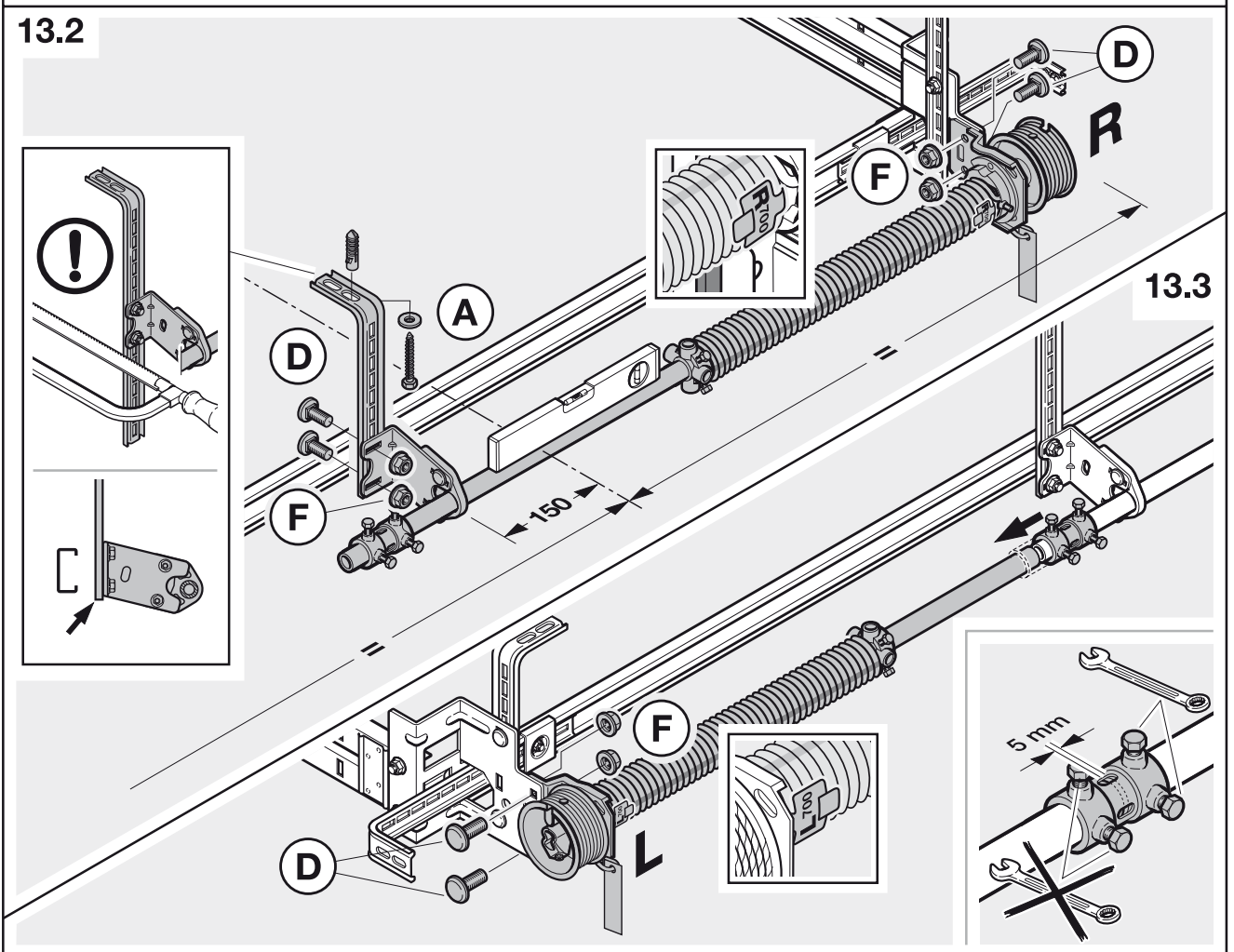
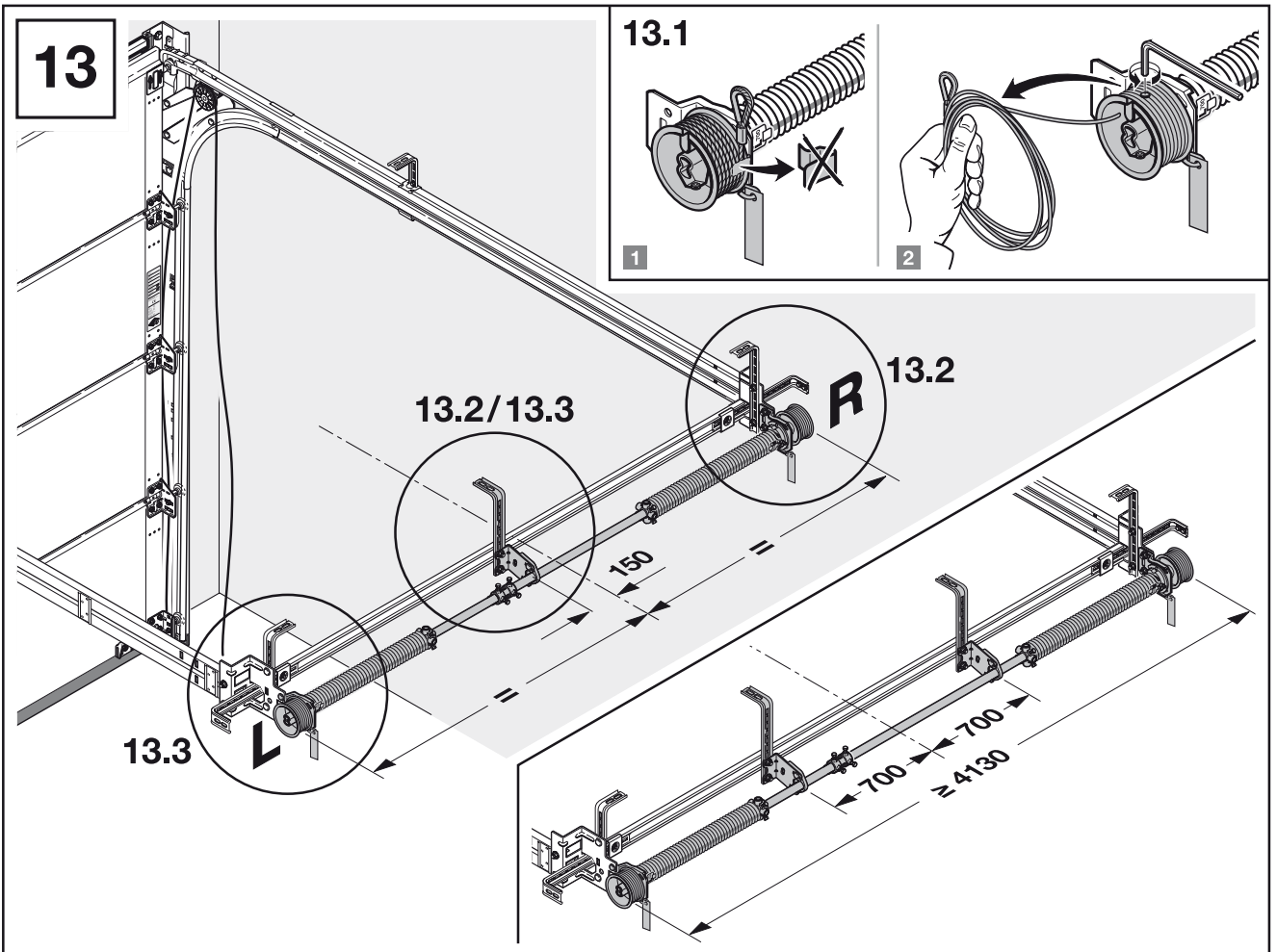

# 14

Auftrags-Nr:  
Order No:  
No. de fabrication:

Typ:  
Door No:  
No. de la porte :

Produkt-Nr:  
Product No:  
No. de produit:

Typ:  
Type:

Flügelgewicht (kg):  
Door weight (kg):  
Poids de la porte (kg): **Y kg**

Federspannung:  
No. of spring turns:  
Nombre de tours:

Federspannung:  
No. of spring turns:  
Nombre de tours: **X**

Baujahr:  
Produced in:  
Année:

Feder links / Feder rechts: **L**  
Spring left / Spring right:  
Ressort gauche/Ressort droite: **R**



Windlast  
Wind load  
Charge au vent

Wasserdichtheit  
Water tightness  
Étanchéité à l'eau

Wärmeisolation  
Thermal resistance W/m<sup>2</sup>K  
Perméabilité à l'air

Luftdurchlässigkeit  
Air permeability  
Perméabilité à l'air

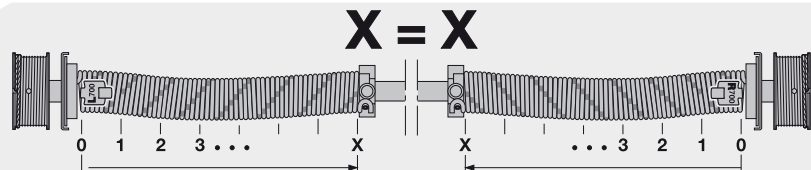
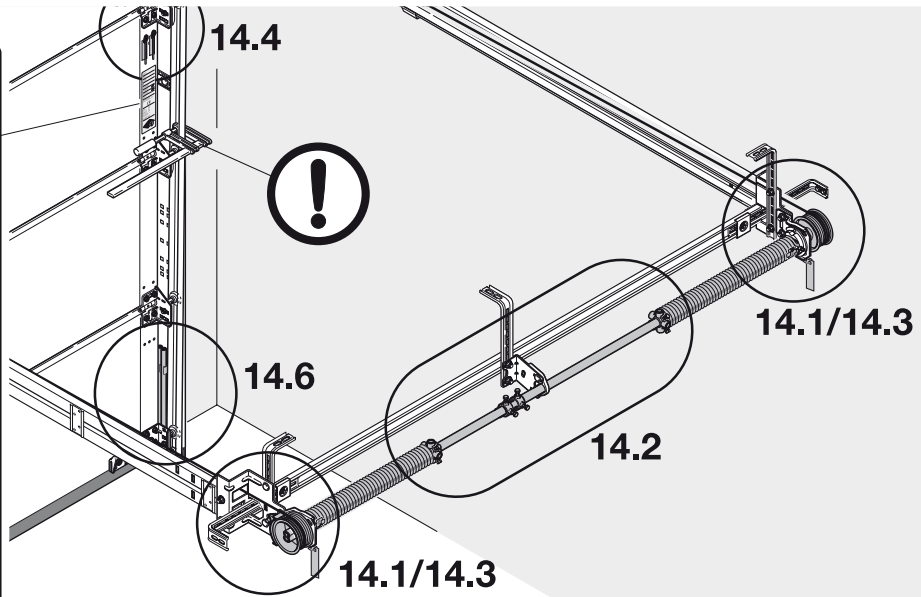

## 14.1

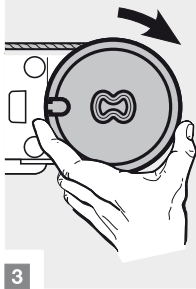
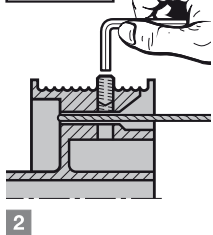
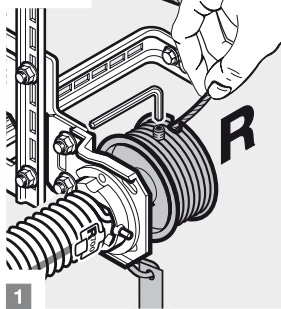

## 14.3

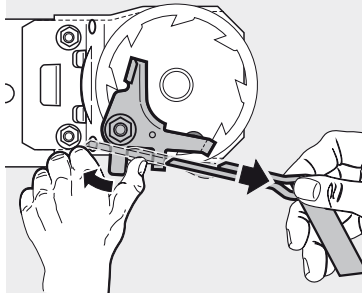
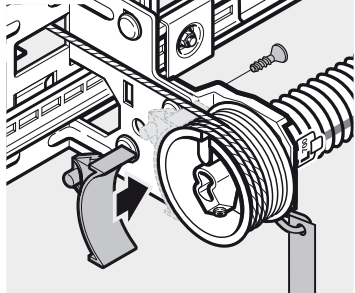

## 14.4

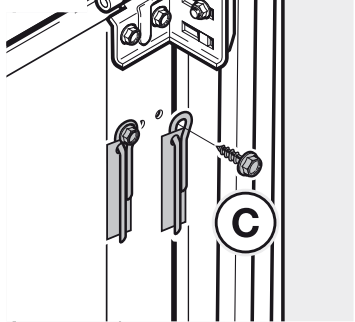

## 14.5

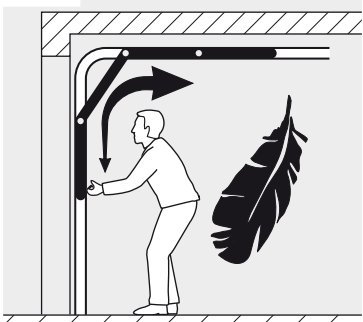

## 14.6

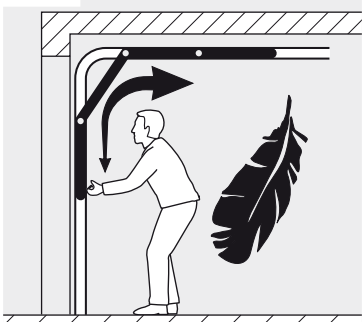
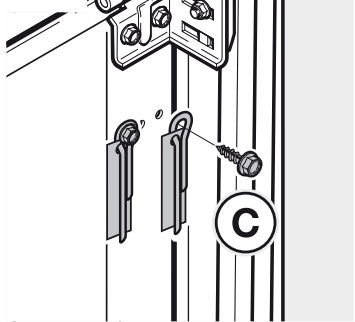

## 14.2

