

3 052 531 RE / (St. 08.2010) 08.2010

**DE**

## **Anleitung für Montage, Betrieb, Wartung und Demontage**

Sectionaltore für Garage Baureihe 40

**EN**

## **Instructions for Fitting, Operating, Maintenance and Dismantling**

Series 40 Sectional Garage Doors

**FR**

## **Notice de montage, d'utilisation, d'entretien et de démontage**

Porte sectionnelle de garage série 40

**ES**

## **Instrucciones para el montaje, funcionamiento, mantenimiento y desmontaje**

Puertas seccionales de garaje de la serie 40

**RU**

## **Руководство по монтажу, эксплуатации, техобслуживанию и демонтажу**

Секционные ворота для гаража строительной серии 40

**+**

**NL** NEDERLANDS

**IT** ITALIANO

**PT** PORTUGUÊS

**PL** POLSKI

**HU** MAGYAR

**CS** ČESKY

**SK** SLOVENSKO

**NO** NORSK

**SV** SVENSKA

**FI** SUOMI

**DA** DANSK

**SL** SLOVENSKY

**TR** TÜRKÇE

**LT** LIETUVIŲ KALBA

**ET** EESTI

**LV** LATVIEŠU VALODA

**HR** HRVATSKI

**SR** SRPSKI

**EL** ΕΛΛΗΝΙΚΑ

**RO** ROMÂNĂ

**BG** БЪЛГАРСКИ

DEUTSCH .....	3
ENGLISH .....	7
FRANÇAIS .....	11
ESPAÑOL .....	15
РУССКИЙ .....	19
NEDERLANDS .....	23
ITALIANO .....	27
PORTUGUÊS .....	31
POLSKI .....	35
MAGYAR .....	39
ČESKY .....	43
SLOVENSKO .....	47
NORSK .....	51
SVENSKA .....	55
SUOMI .....	59
DANSK .....	63
SLOVENSKY .....	67
TÜRKÇE .....	71
LIETUVIŲ KALBA .....	75
EESTI .....	79
LATVIEŠU VALODA .....	83
HRVATSKI .....	87
SRPSKI .....	91
ΕΛΛΗΝΙΚΑ .....	95
ROMÂNĂ .....	99
БЪЛГАРСКИ .....	103



.....	107
-------	-----

## Contents

<b>1</b>	<b>About These Instructions.....</b>	<b>7</b>
1.1	Warnings used.....	7
<b>2</b>	<b>⚠ Safety Instructions.....</b>	<b>7</b>
2.1	Intended use.....	7
2.2	General safety instructions.....	7
2.3	Environmental conditions .....	8
<b>3</b>	<b>Fitting.....</b>	<b>8</b>
3.1	Tensioning the springs.....	8
<b>4</b>	<b>Operation.....</b>	<b>8</b>
4.1	Operating the door .....	8
4.2	Locking and unlocking .....	9
<b>5</b>	<b>Cleaning and Care .....</b>	<b>9</b>
<b>6</b>	<b>Inspection and Maintenance .....</b>	<b>9</b>
6.1	Inspections and maintenance .....	9
<b>7</b>	<b>Malfunctions and Troubleshooting .....</b>	<b>10</b>
7.1	Paint treatment.....	10
<b>8</b>	<b>Dismantling .....</b>	<b>10</b>



.....107

Dear Customer,

We are delighted that you have chosen a quality product from our company.

## 1 About These Instructions

These instructions are divided into a text section and an illustrated section. The illustrated section can be found after the text section.

These instructions are **original instructions** as outlined in the EC Directive 2006/42/EC. Read and follow these instructions carefully. They contain important information concerning the product. Please pay particular attention to all safety and warning notices.

**Keep these instructions in a safe place for later reference!**

### 1.1 Warnings used



The general warning symbol indicates a danger that can lead to **injury** or **death**. In the text, the general warning symbol will be used in connection with the caution levels described below. In the illustrated section, an additional instruction refers back to the explanation in the text.

#### **WARNING**

Indicates a danger that can lead to death or serious injuries.

#### **ATTENTION**

Indicates a danger that can lead to **damage** or **destruction** of the product.

## 2 ⚠ Safety Instructions

### 2.1 Intended use

This garage door is designed and intended for private use only.

Continuous operation is not permitted.

### 2.2 General safety instructions

- Fitting, maintenance, repair and dismantling of the Series 40 sectional garage door may only be carried out by specialists (competent persons in accordance with EN 12635).
- In the event of a door failure (sluggish operation or other malfunctions), a specialist must be commissioned immediately for the inspection/repair work.
- The specialist must ensure that the respective national regulations regarding occupational safety are complied with.
- Before the door is put into service, it must be tested to make sure that it is mechanically sound, in perfect working order as well as correctly balanced, making it also easy to operate manually (EN 12604).
- The field of application for Series 40 sectional doors is laid down in EN 13241-1.
- When the door is fitted, attention must be paid to potential hazards as defined in EN 12604 and EN 12453.

Dissemination as well as duplication of this document and the use and communication of its content are prohibited unless explicitly permitted. Noncompliance will result in damage compensation obligations. All rights reserved in the event of patent, utility model or design model registration. Subject to changes.

### 2.3 Environmental conditions

<b>ATTENTION</b>	
<b>Damage due to temperature differences</b>	
Differences in the inside and outside temperatures may cause deflection of the door elements (bi-metal effect). This may result in damage when the door is operated.	
▶ Comply with the operating conditions.	

The door is intended for the following operating conditions:

Temperature:

- Exterior side -40°C to +60°C
- Interior side -20°C to +60°C

Relative humidity: 20% to 90%

### 3 Fitting

<b>⚠ WARNING</b>	
<b>Danger of injury as the result of structural modifications</b>	
Changing or removing functional parts may put important safety components out of action. Uncontrolled door travel could occur and persons or objects may be trapped as a result.	
▶ Do not alter or remove any functional parts.	
▶ Do not attach any additional components. The torsion springs are precisely matched to the door leaf weight. Additional components may overload the springs.	
▶ If equipping the door with an operator, pay attention to the instructions provided by the manufacturers of the door and operator. Only use the original connections of the door manufacturer!	

Before fitting the door, the door opening and the building floor must be completely finished.

Observe the following during fitting:

- Establish a secure connection with the building structure.
- Check that the fixing materials supplied are suitable for the given structural conditions.
- Do not fasten the door system to supporting structural members unless you have obtained the prior approval of the structural engineer.
- Ensure adequate water run-off in the area of the bottom seal and the frame parts, otherwise there is a danger of corrosion. (see Technical Manual)
- Ensure sufficient drying and ventilation in the building, otherwise there is danger of corrosion.
- The door must be effectively protected before carrying out plastering and paintwork, as splashes of mortar, cement, plaster, paint etc. can damage the door surface.
- Protect the door from caustic, aggressive substances, e.g. nitrous reactions from stones or mortar, acids, alkali solutions, de-icing salt, aggressive paints or sealants. Failure to do so, could lead to corrosion.
- ▶ **To ensure simple and secure fitting, please follow the work steps listed in the illustrated section.**

### 3.1 Tensioning the springs

<b>⚠ WARNING</b>	
<b>Danger of injury due to high spring tension</b>	
Springs are under high tension and may discharge high forces if they are not secured during tensioning.	
▶ Fix the door leaf to prevent uncontrolled movement before adjusting the tension springs.	

When the springs are tensioned correctly, the moving door leaf has a slight tendency to pull upwards.

- ▶ Each time the door is serviced, the tension of the springs should be checked and, if necessary, subsequently re-adjusted.
- ▶ **Before putting the door into operation for the first time, inspect the door according to the chapter *Inspection and Maintenance!***

### 4 Operation

#### 4.1 Operating the door

<b>⚠ WARNING</b>	
<b>Danger of injury during door travel</b>	
The sectional door opens to the top vertically; persons or objects may be trapped.	
▶ When operating the door, always make sure that there are no objects or persons, especially children, within the door's range of movement!	
▶ Always keep the opening area of the door clear.	
▶ Do not operate the door in strong winds.	

The door must only be operated by **suitably instructed** persons. If the sectional door is competently fitted and inspected, it can be easily moved and operated.

#### 4.1.1 Manually operated doors

<b>⚠ WARNING</b>	
<b>Danger of injury due to improper operation</b>	
Persons or objects may be trapped if the door is operated improperly.	
▶ Only open and close the door using the supplied operating elements; these ensure a controlled, smooth action.	
▶ When closing the door, make sure that the latches engage fully and correctly.	

#### 4.1.2 Power-driven doors

The automation of a sectional door requires that special safety regulations be observed. Consult your supplier.

## 4.2 Locking and unlocking

The door is not locked when closed with the grip handle. This is done by using the key or locking lever on the lock.

### From outside:

- ▶ Turn the key 360°
  - To unlock: turn the key left
  - To lock: turn the key right

### From inside:

- ▶ Slide the locking lever on the lock
  - To unlock: slide it upwards
  - To lock: slide it downwards

## 5 Cleaning and Care

<b>ATTENTION</b>
<p><b>Scratches on the panes due to improper cleaning</b> Rubbing the panes causes scratches.</p> <ul style="list-style-type: none"> <li>▶ Dirt and dust particles must first be thoroughly rinsed off with water. If necessary, only wash with water, a pH-neutral household detergent and a soft, clean cloth.</li> </ul>

**Clear water is sufficient for cleaning and care.** Use warm water together with a neutral, non-abrasive cleaning agent (household detergent, pH value 7) if more heavily soiled. To preserve the surface characteristics, **regular cleaning must be carried out at least every 3 months** (outside of door, seals). The slide area behind the side seals must be kept permanently clean and able to slide.

A variety of environmental influences (e.g. maritime climate, acids, road salt, air pollutants, paint damage) may make additional protective coating necessary (see *Paint treatment* on page 10).

## 6 Inspection and Maintenance

### 6.1 Inspections and maintenance

<b>⚠ WARNING</b>
<p><b>Danger of injury due to defective safety components</b> Important safety components may fail or become defective if not sufficiently inspected and maintained.</p> <ul style="list-style-type: none"> <li>▶ Have a qualified person perform inspection and maintenance work at regular intervals.</li> </ul>

The following inspection and maintenance tasks must be carried out by a specialist in accordance with these instructions, before initial operation and at least once a year (or every 6 months if there are more than 50 door cycles per day)!

### 6.1.1 Inspect all load-bearing components

<b>⚠ WARNING</b>
<p><b>Danger of injury due to high cable tension</b> Cables are under high tension. Damaged cables may cause serious injuries.</p> <ul style="list-style-type: none"> <li>▶ Fix the door leaf to prevent movement before exchanging damaged cables.</li> <li>▶ Be particularly careful when exchanging damaged cables.</li> </ul>

- ▶ Check load carriers (cables, springs, tracks, supports) and safety devices for breakage and damage, replacing any damaged components as necessary.

### 6.1.2 Weight counterbalance

<b>⚠ WARNING</b>
<p><b>Danger of injury due to uncontrolled door drops</b> If the counterbalance has not been properly adjusted, this may result in an uncontrolled door drop, which could trap persons or objects.</p> <ul style="list-style-type: none"> <li>▶ Retighten the tension springs.</li> </ul>
<p><b>High spring tension</b> Springs are under high tension and may discharge high forces if they are not secured during tensioning.</p> <ul style="list-style-type: none"> <li>▶ Fix the door leaf to prevent uncontrolled movement before adjusting the tension springs.</li> </ul>

#### Check the counterbalance of the door leaf

- ▶ Open the door manually up to the half-way point. The door must be capable of holding this position.

#### If the door moves substantially downwards:

- ▶ Re-adjust the tension of the springs

### 6.1.3 Fixing points

- ▶ Check all the fixing points on the door and the building structure and make sure that all the fastenings are securely seated and, if necessary, retighten.

### 6.1.4 Rollers and tracks

- When the door is closed, the rollers must be easy to turn.
- ▶ Adjust rollers if necessary. Observe the operator fitting notes; they contain details on roller adjustment.
  - ▶ Clean tracks, if necessary, **do not grease!**

### 6.1.5 Hinges and roller holders

- ▶ Oil hinges and roller holders.

### 6.1.6 Locking cylinders

<b>ATTENTION</b>
<p><b>Damage to the locking cylinders due to unsuitable cleaning products</b> Locking cylinders may not be cleaned with agents containing oil or be oiled.</p> <ul style="list-style-type: none"> <li>▶ Only use specialised care products.</li> <li>▶ Do not use oil or graphite.</li> </ul>

### 6.1.7 Seals

- ▶ Check for damage, deformations and completeness. If necessary, replace.

## 7 Malfunctions and Troubleshooting

 <b>WARNING</b>
--

<b>Danger of injury due to uncontrolled door movement</b>
---

If the door malfunctions, uncontrolled door movements may trap persons or objects.
--

- |  |
|--|
| <ul style="list-style-type: none"><li>▶ In the event of a door failure (sluggish operation or other malfunctions), a specialist must be commissioned immediately for the inspection/repair work.</li></ul> |
|--|

### 7.1 Paint treatment

The door leaf is provided with a polyester-primer coating. If you want to paint the door a different colour, or if a renovation coating or additional protective coating is necessary:

- Lightly sand the surface with fine sand paper (at least 180 grain size).
- Clean with water, dry and remove any grease
- Treat further with commercially available synthetic resin paints suitable for outdoor applications.

Avoid dark coatings on double-skinned doors and doors with thermal breaks.

Follow the directions of the paint manufacturer!

## 8 Dismantling

Dismantle the door in accordance with these fitting instructions, in the logically correct reverse order.

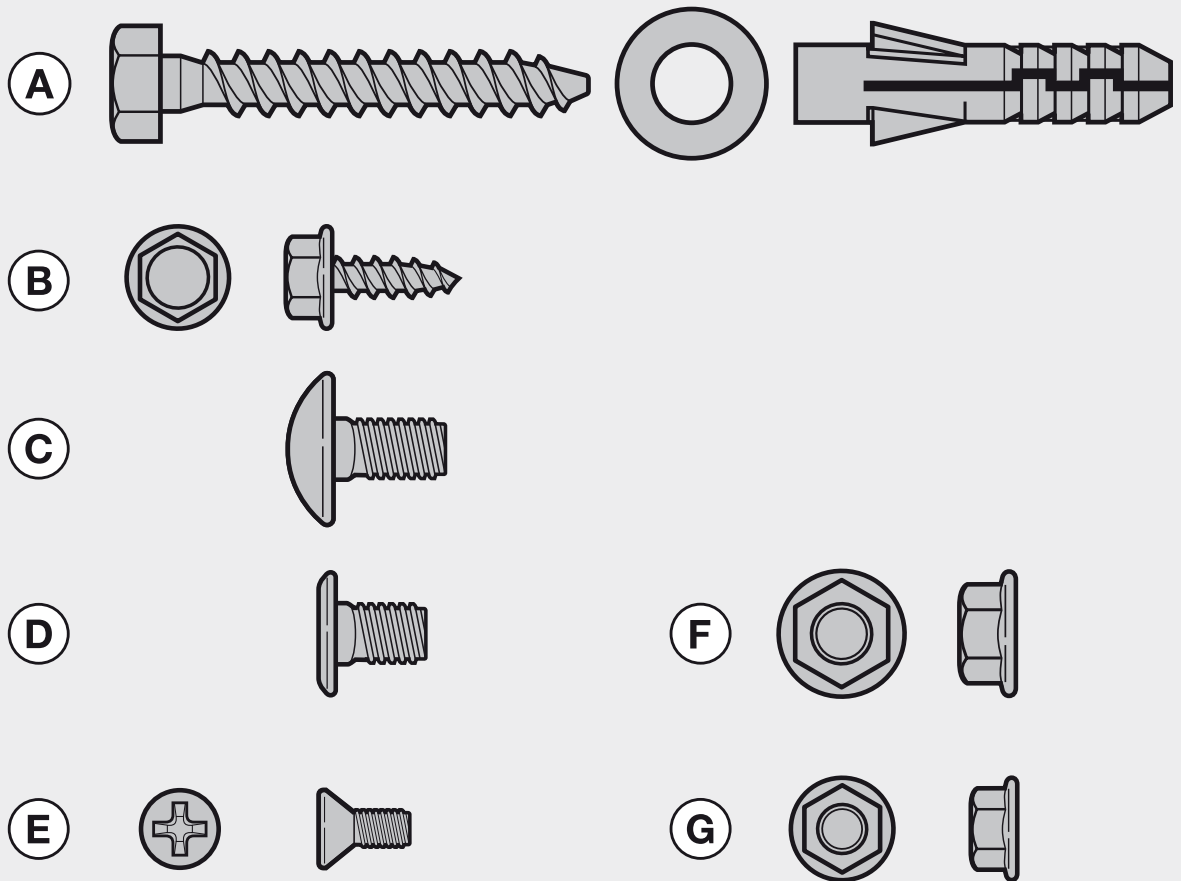
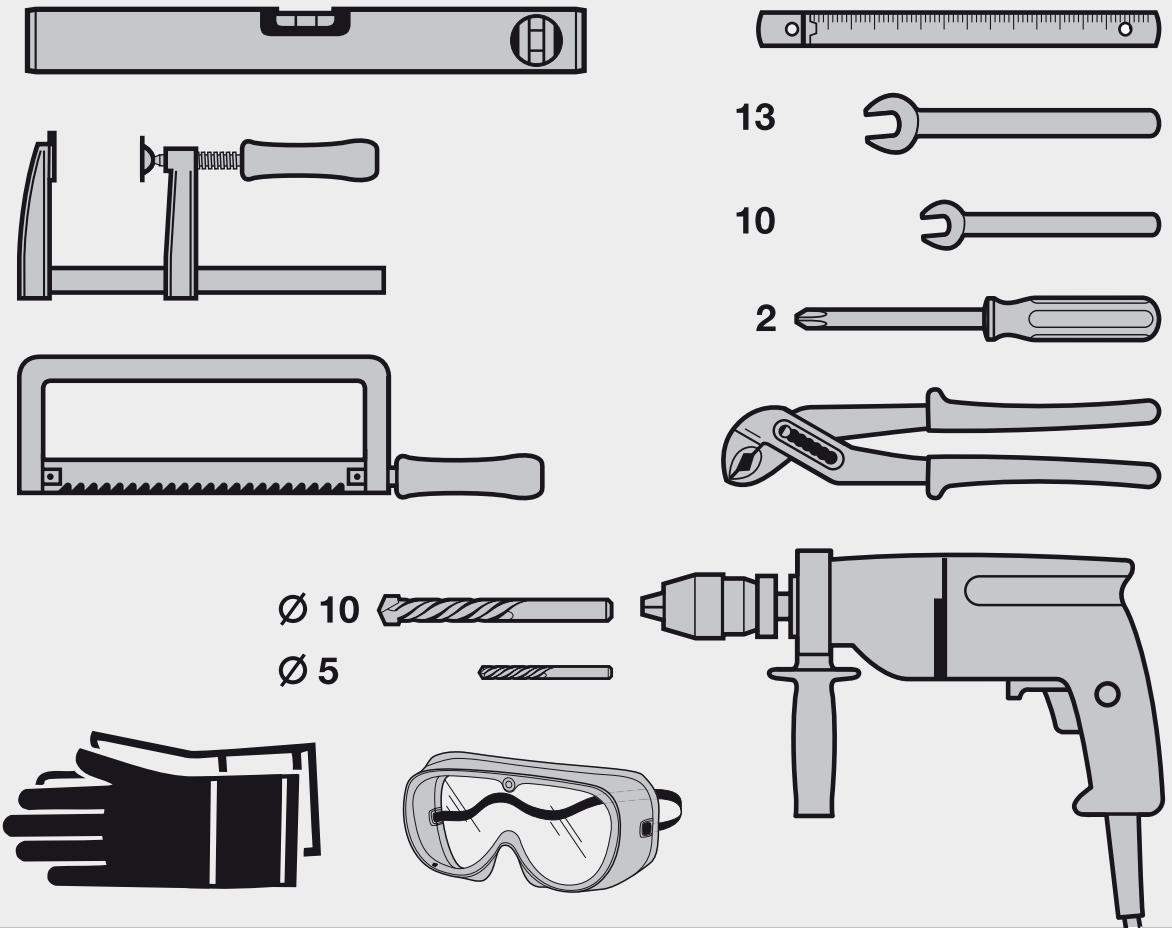

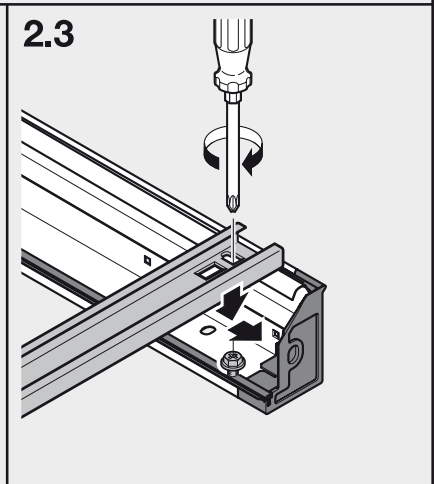
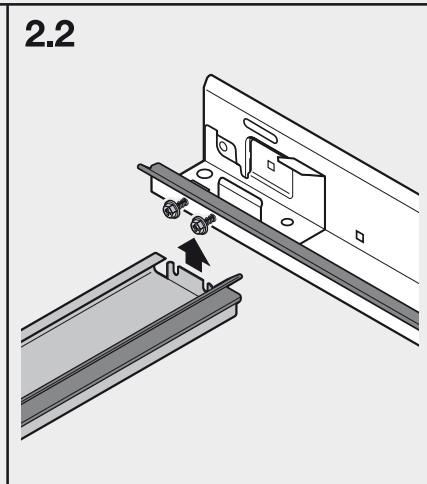
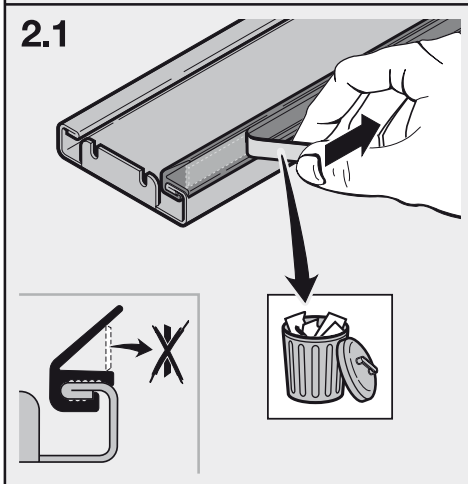
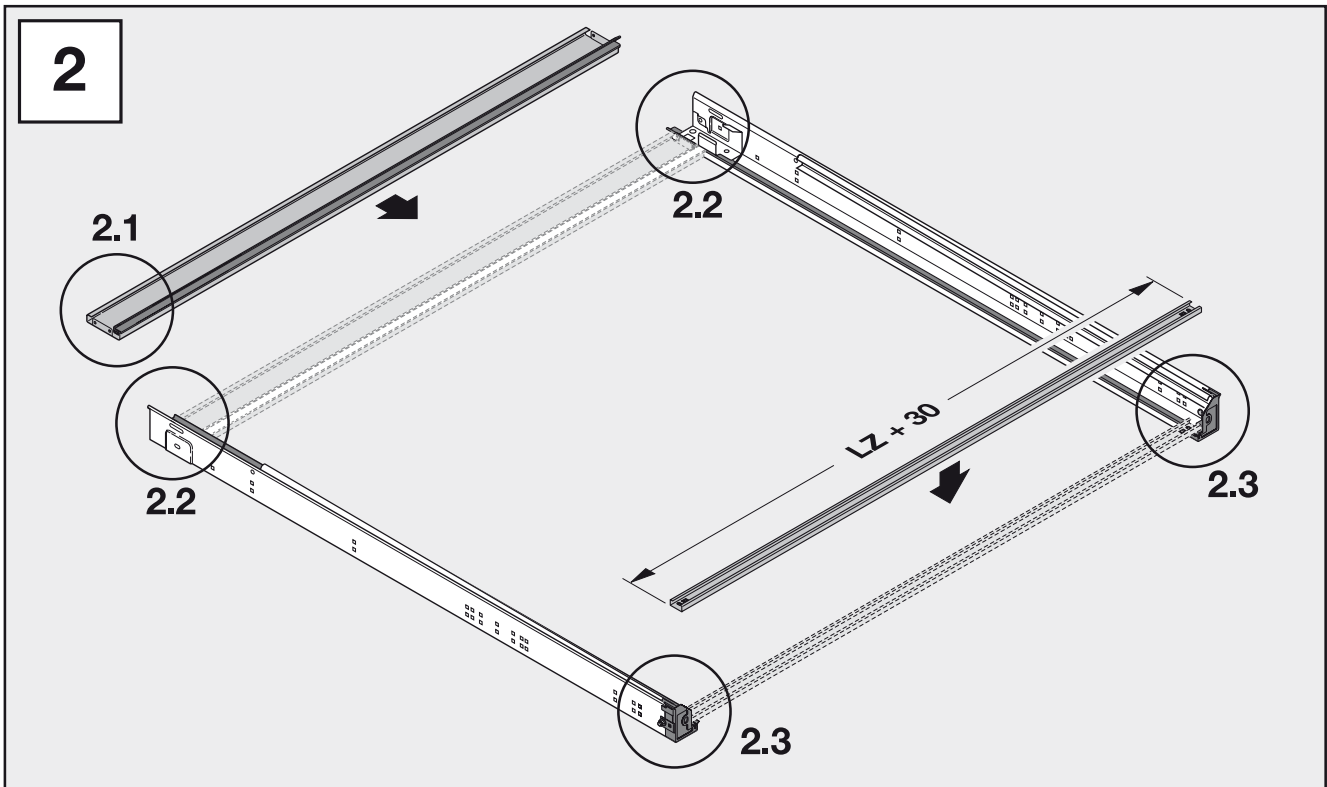
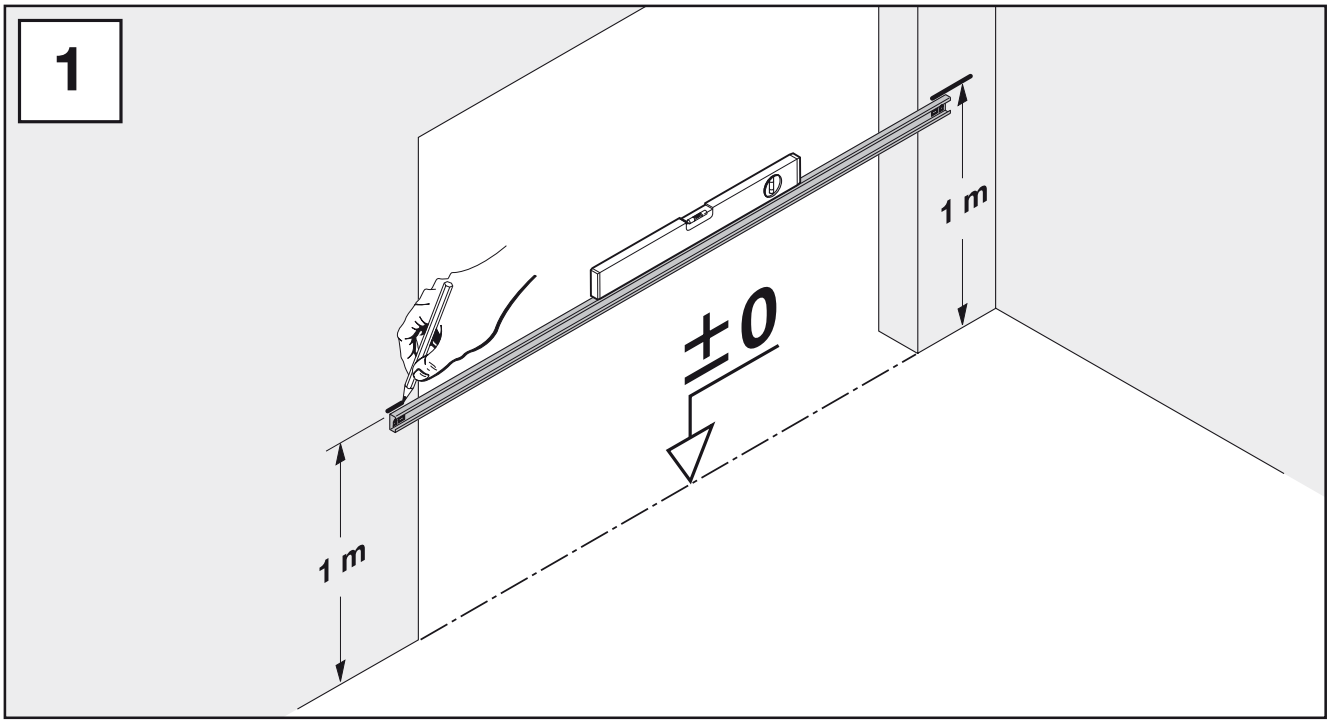



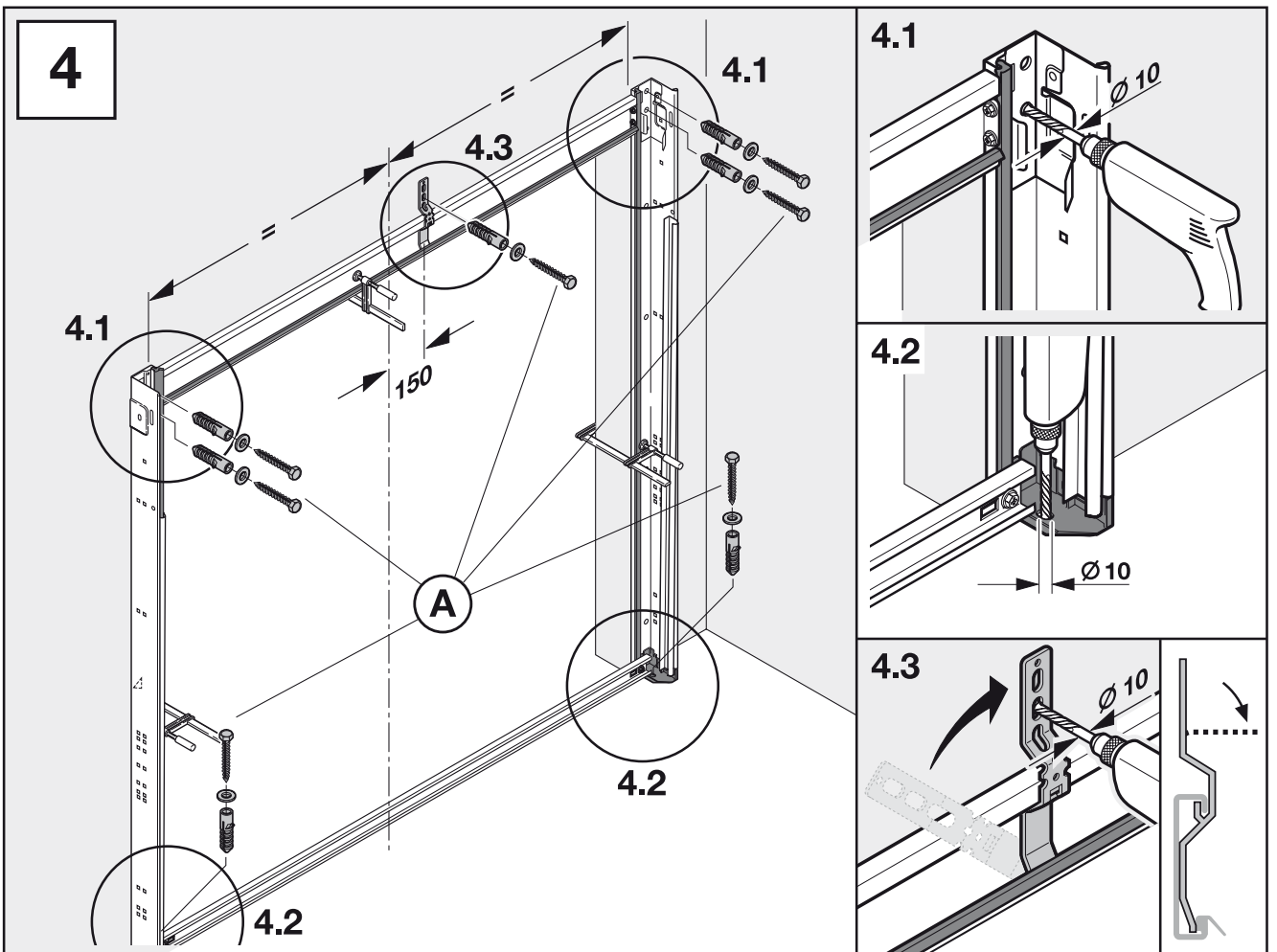
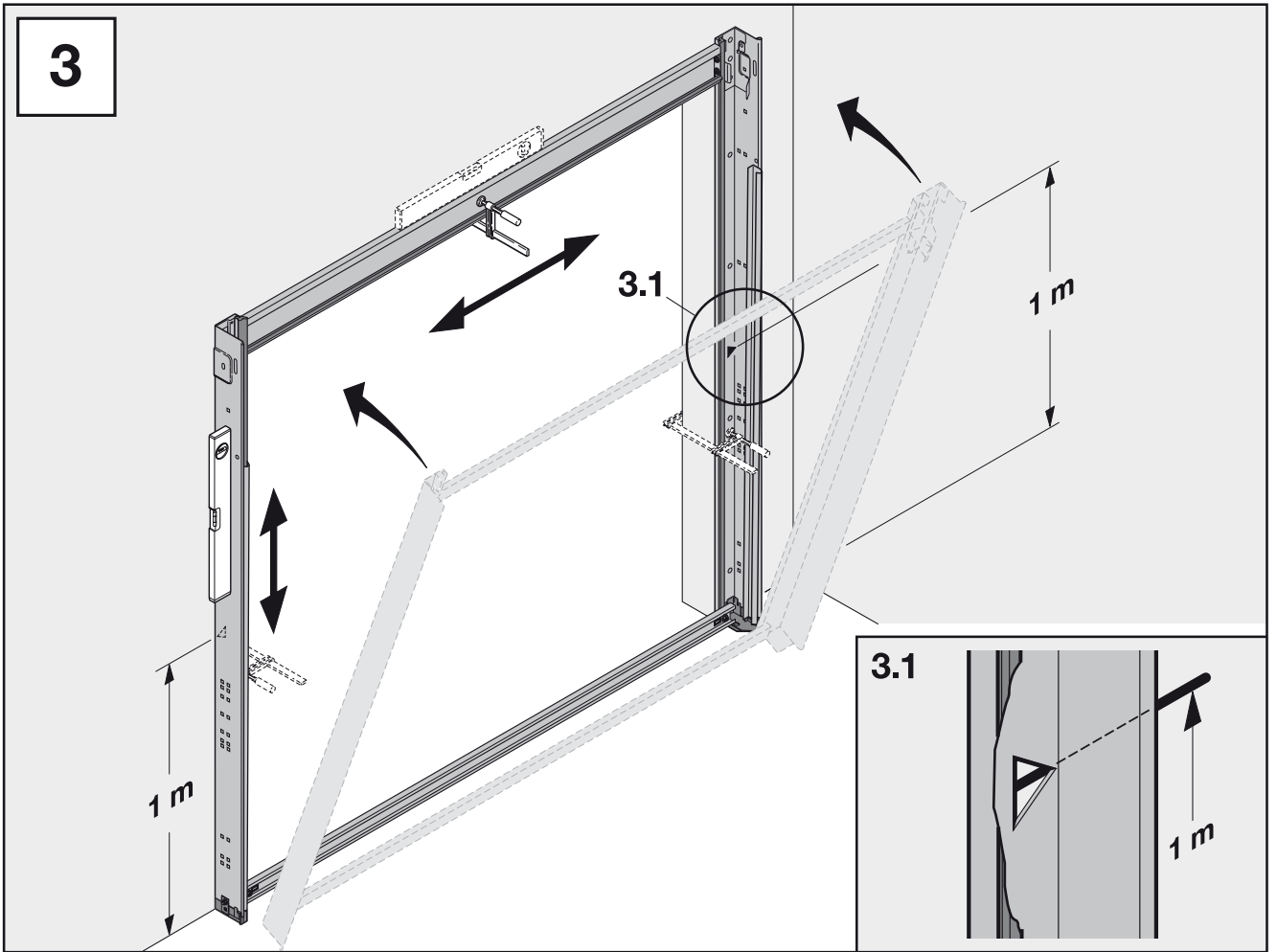

# 5a

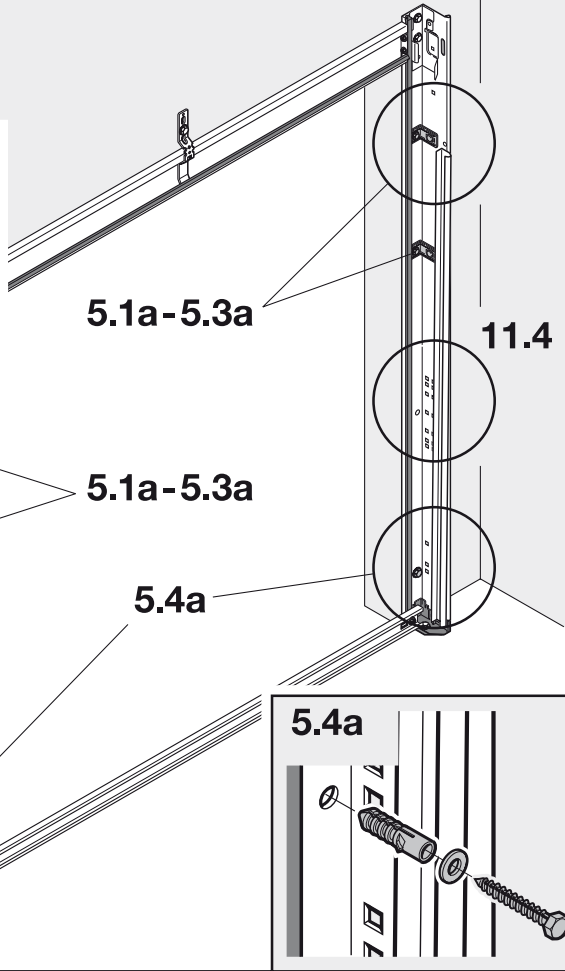
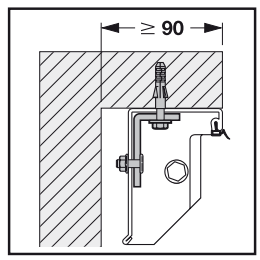

## 5.1a

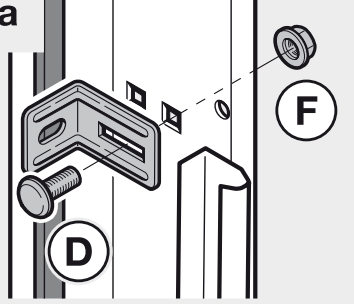

## 5.2a

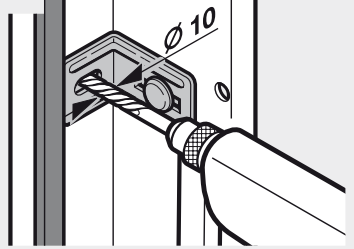

## 5.3a

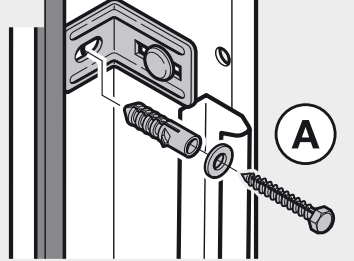

# 5b

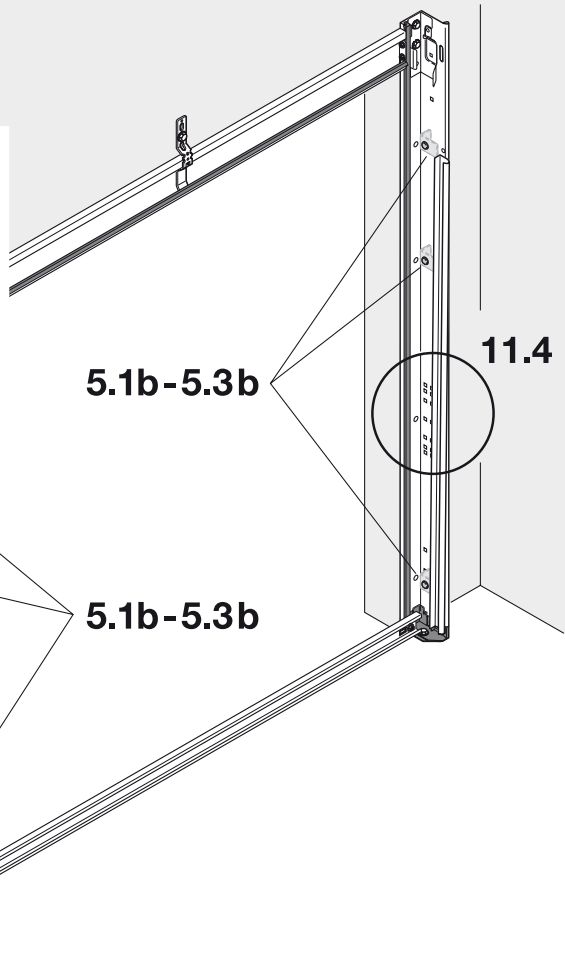
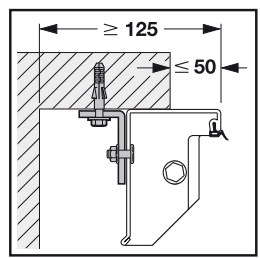

## 5.1b

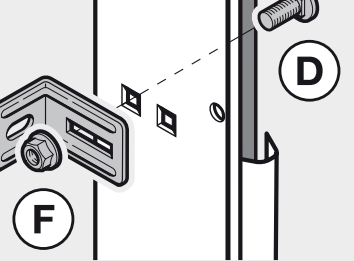

## 5.2b

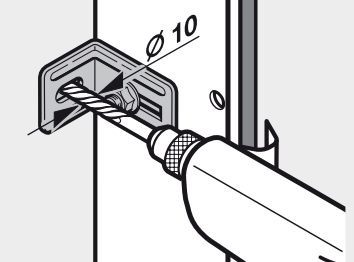

## 5.3b

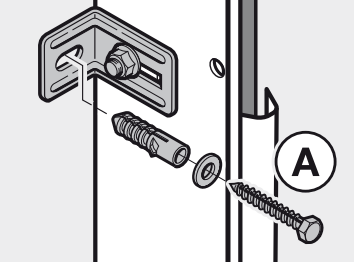

6

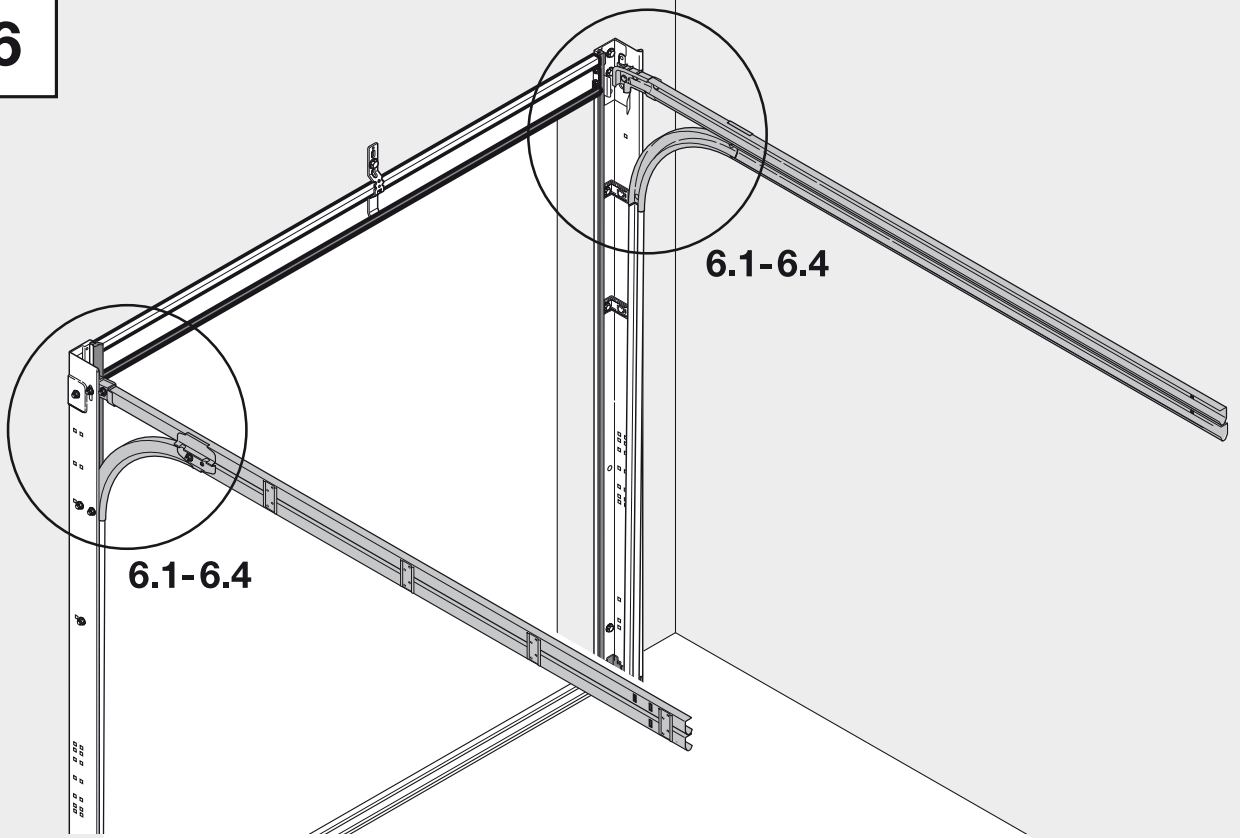

6.1

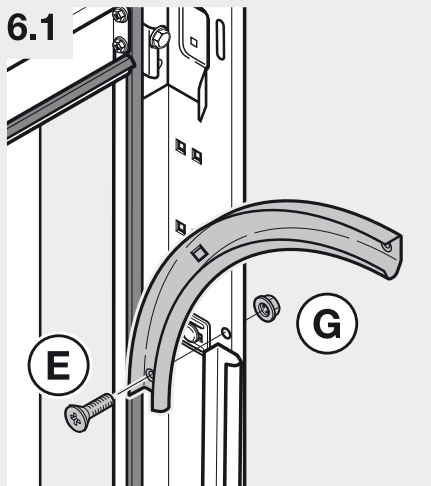

6.2

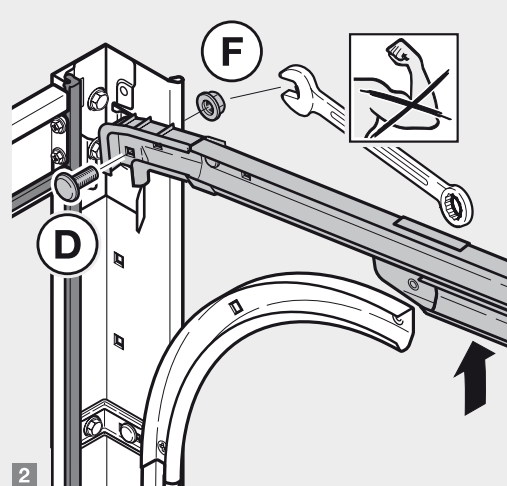
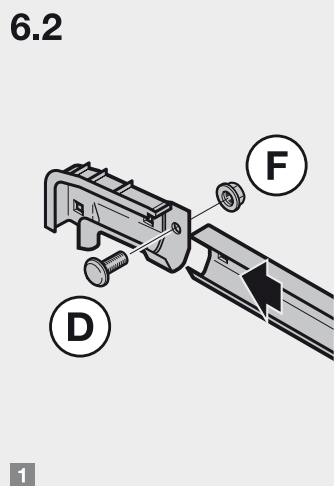

6.3

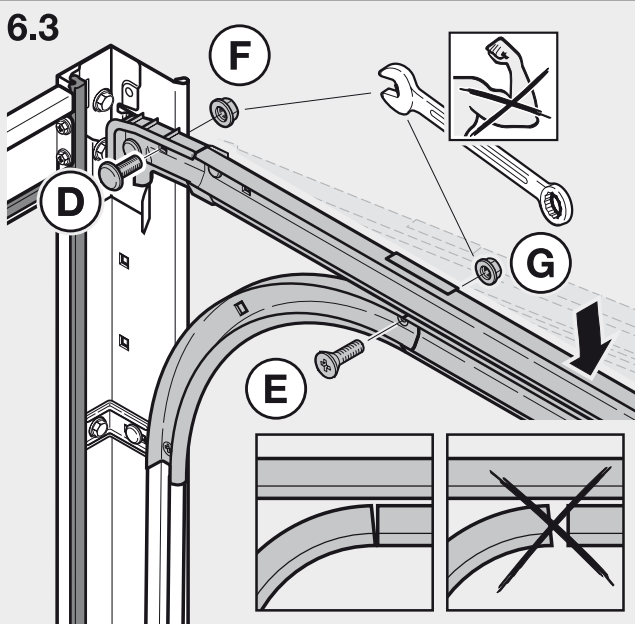

6.4

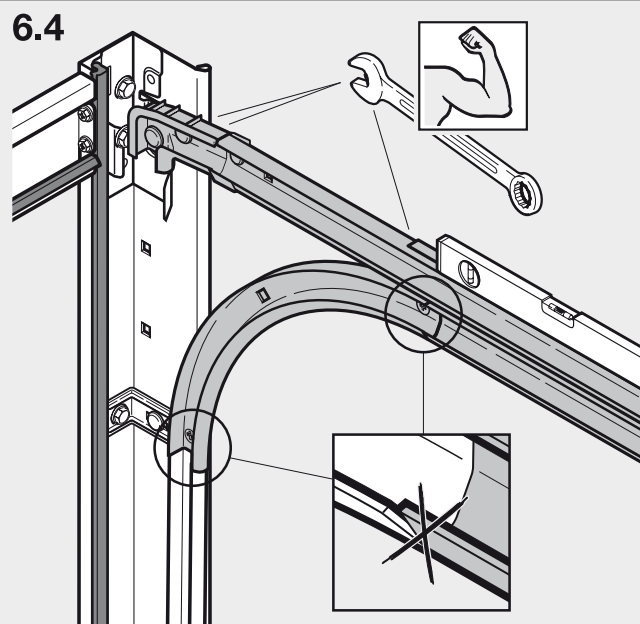

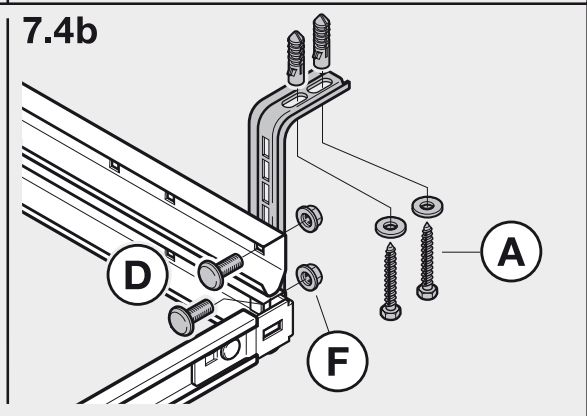
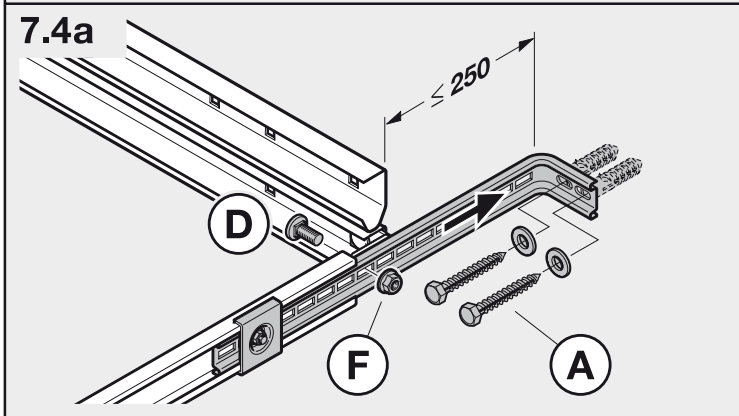
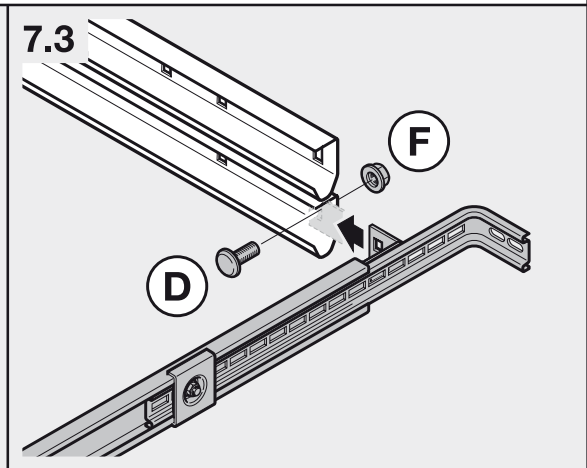
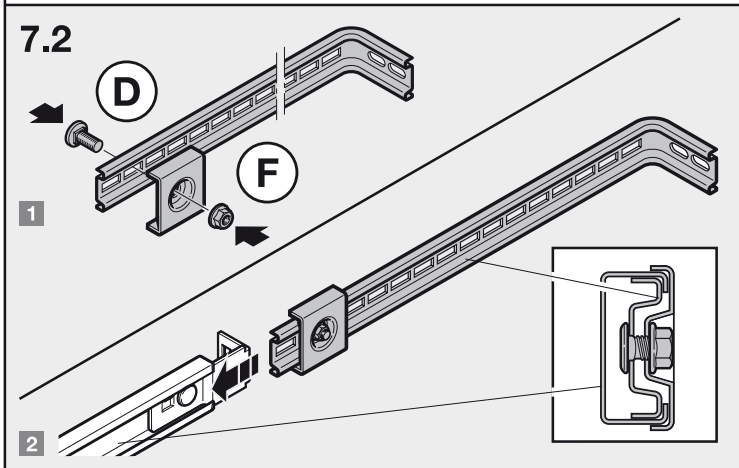
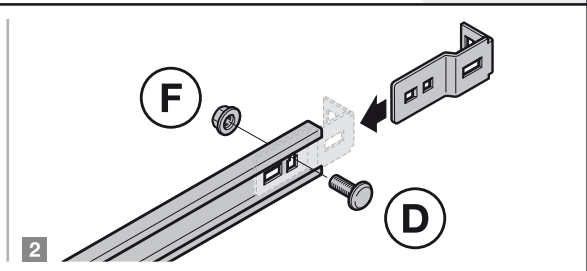
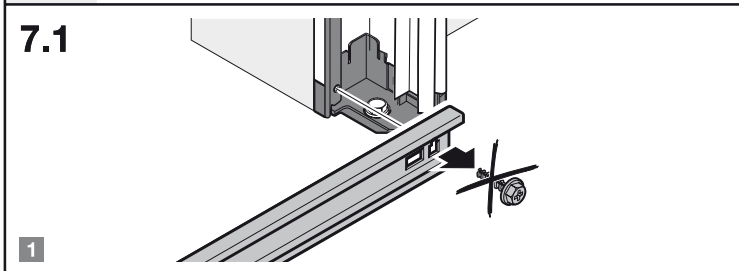
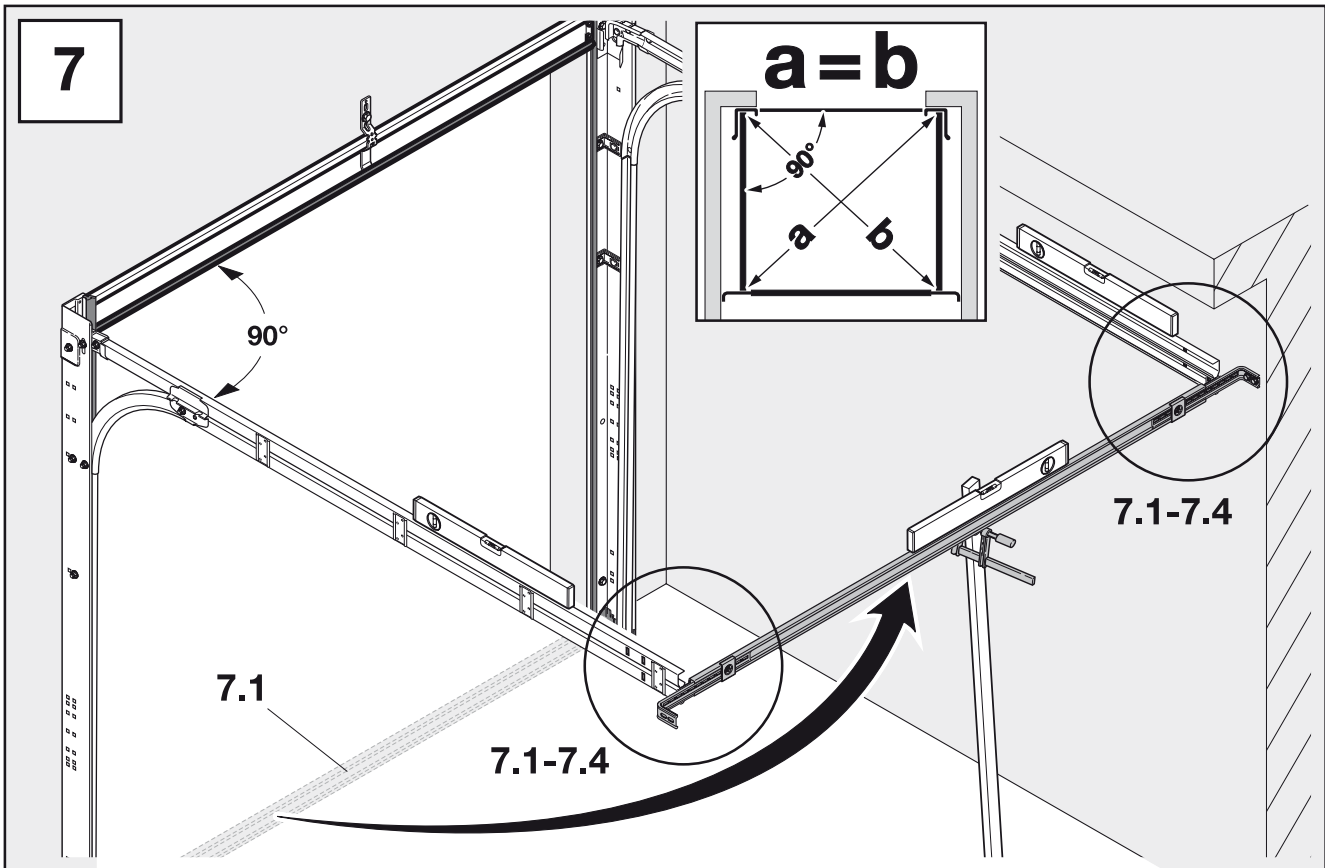

8

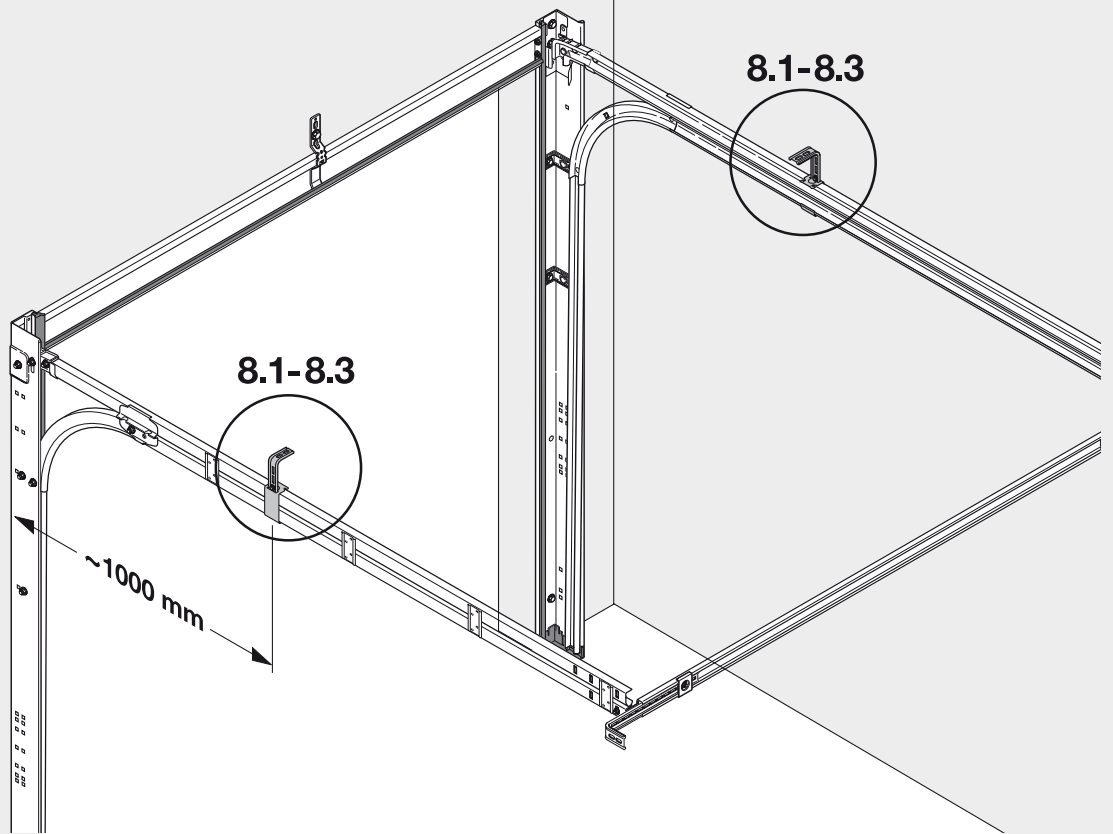

8.1

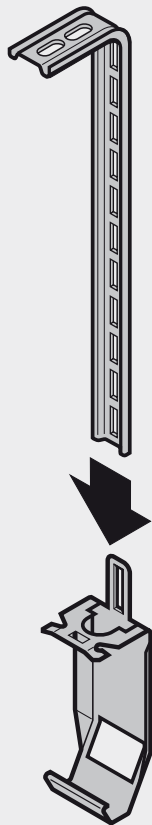

8.2

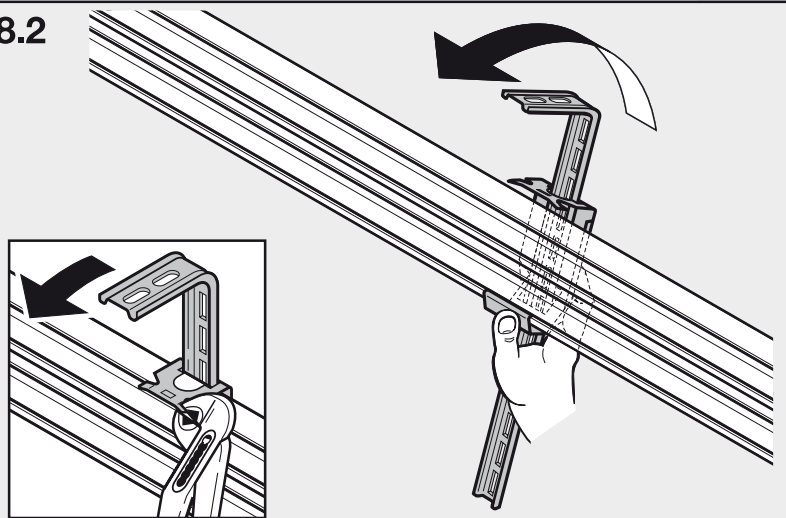

8.3

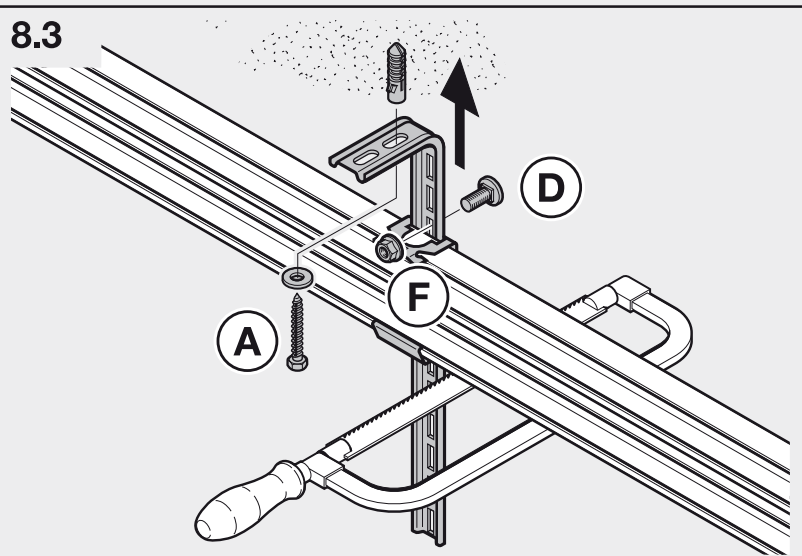

9

9.1/9.2

9.1/9.2

9.3

9.3

9.1

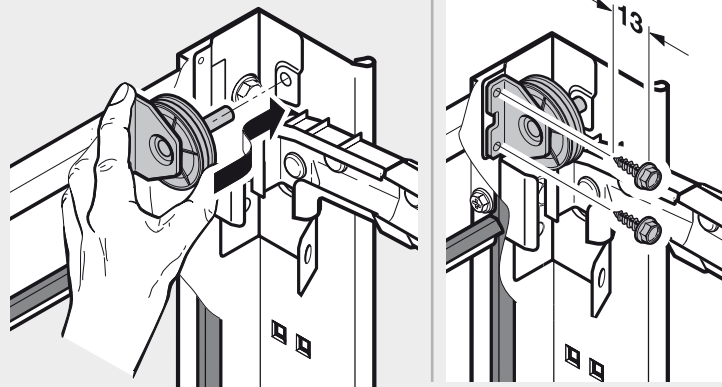

9.2

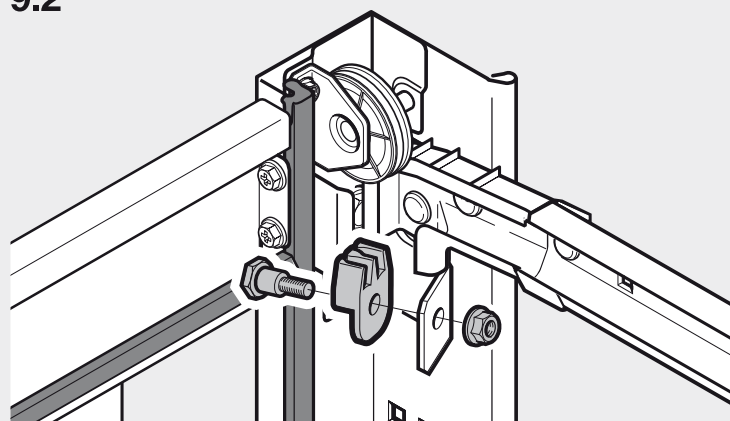

9.3

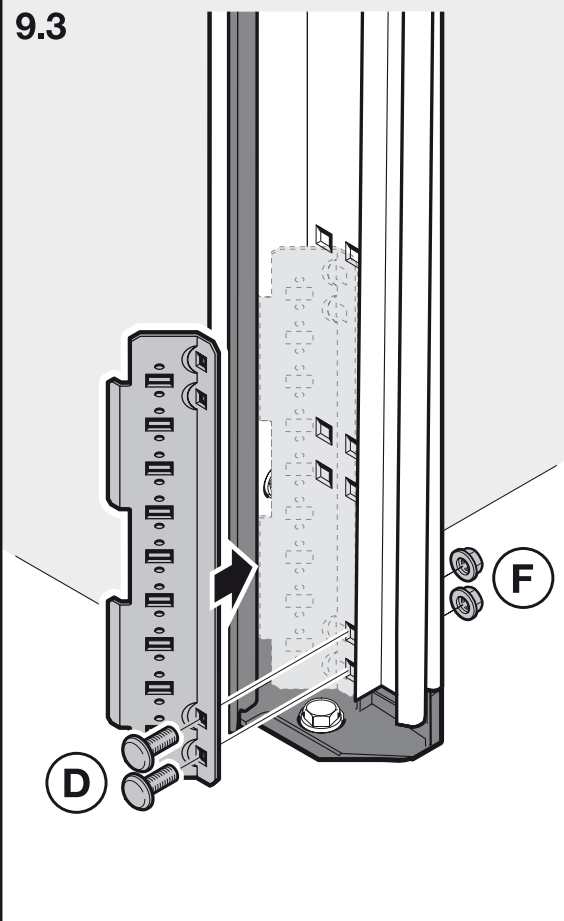



10

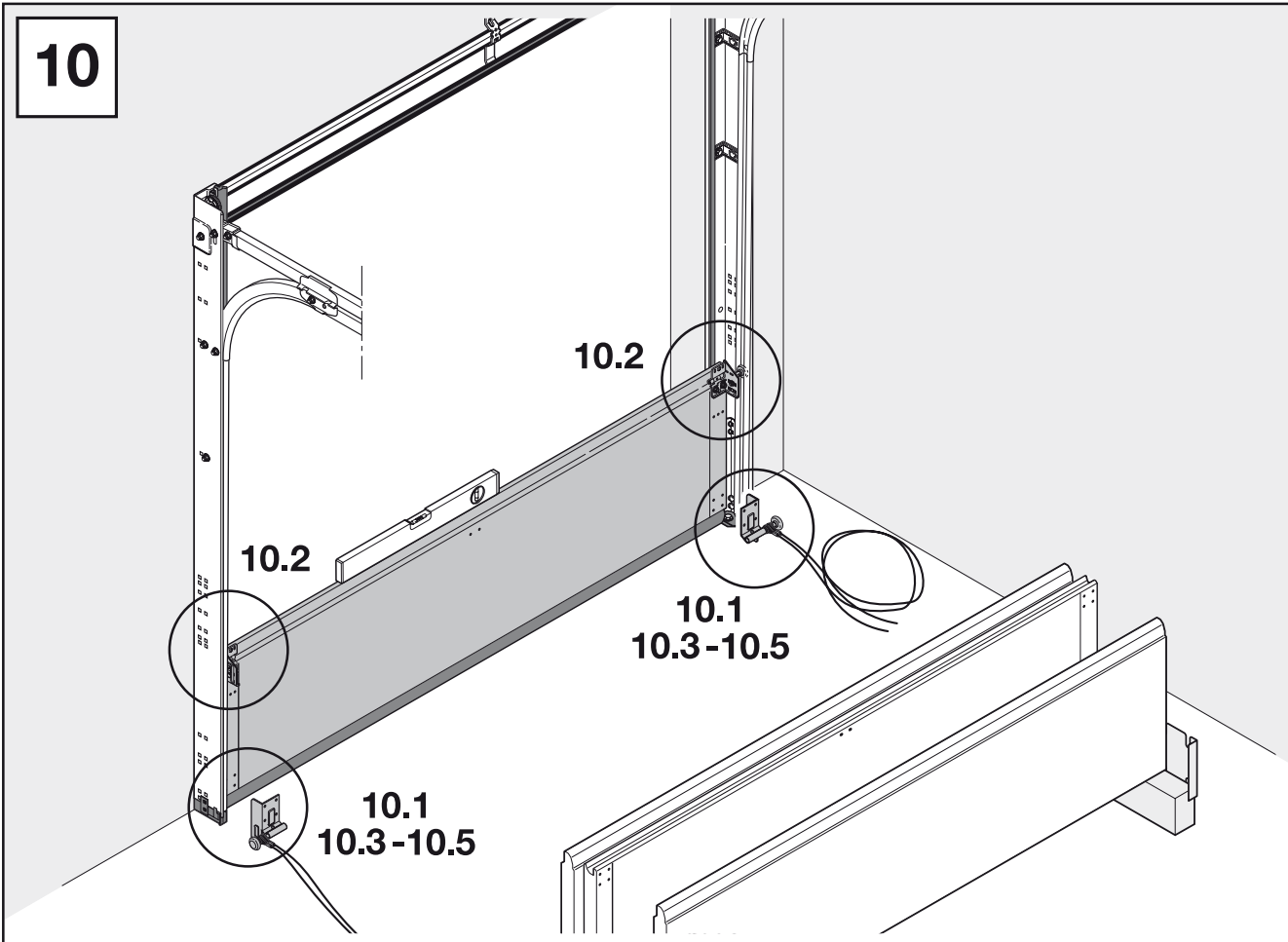

10.1a

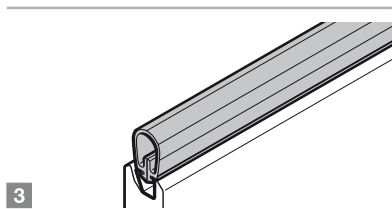
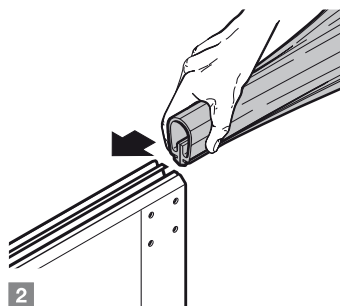
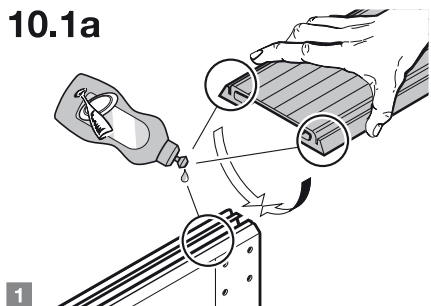

10.1b

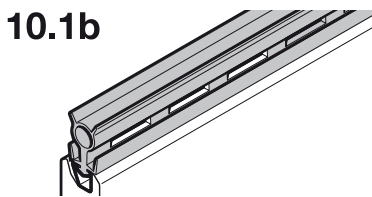

10.2

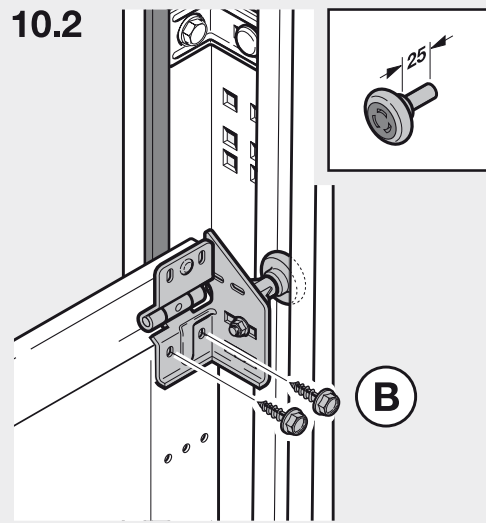

10.3

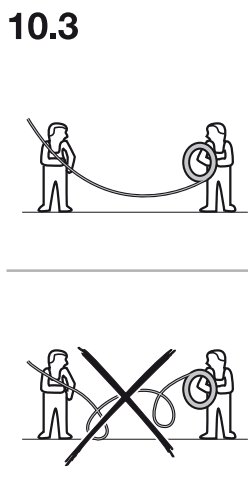

10.4

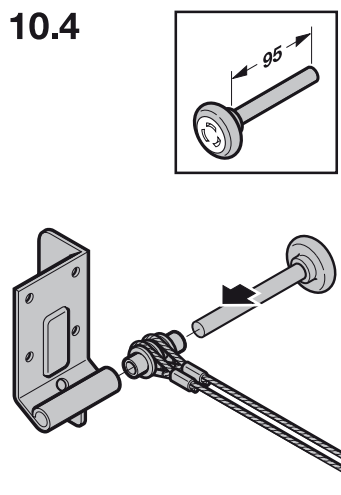

10.5a

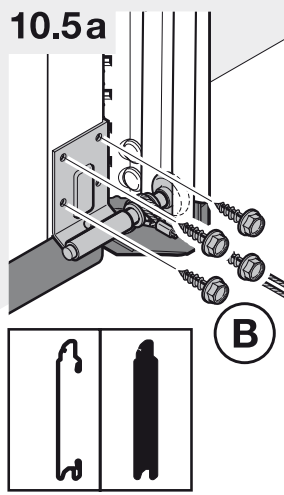

10.5b

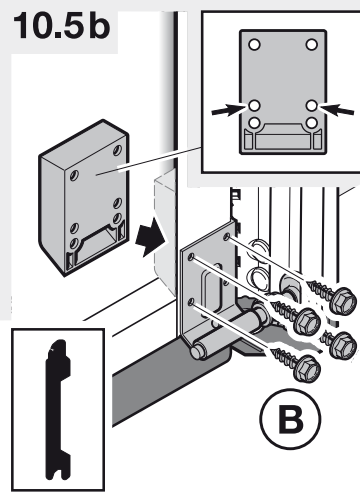

11

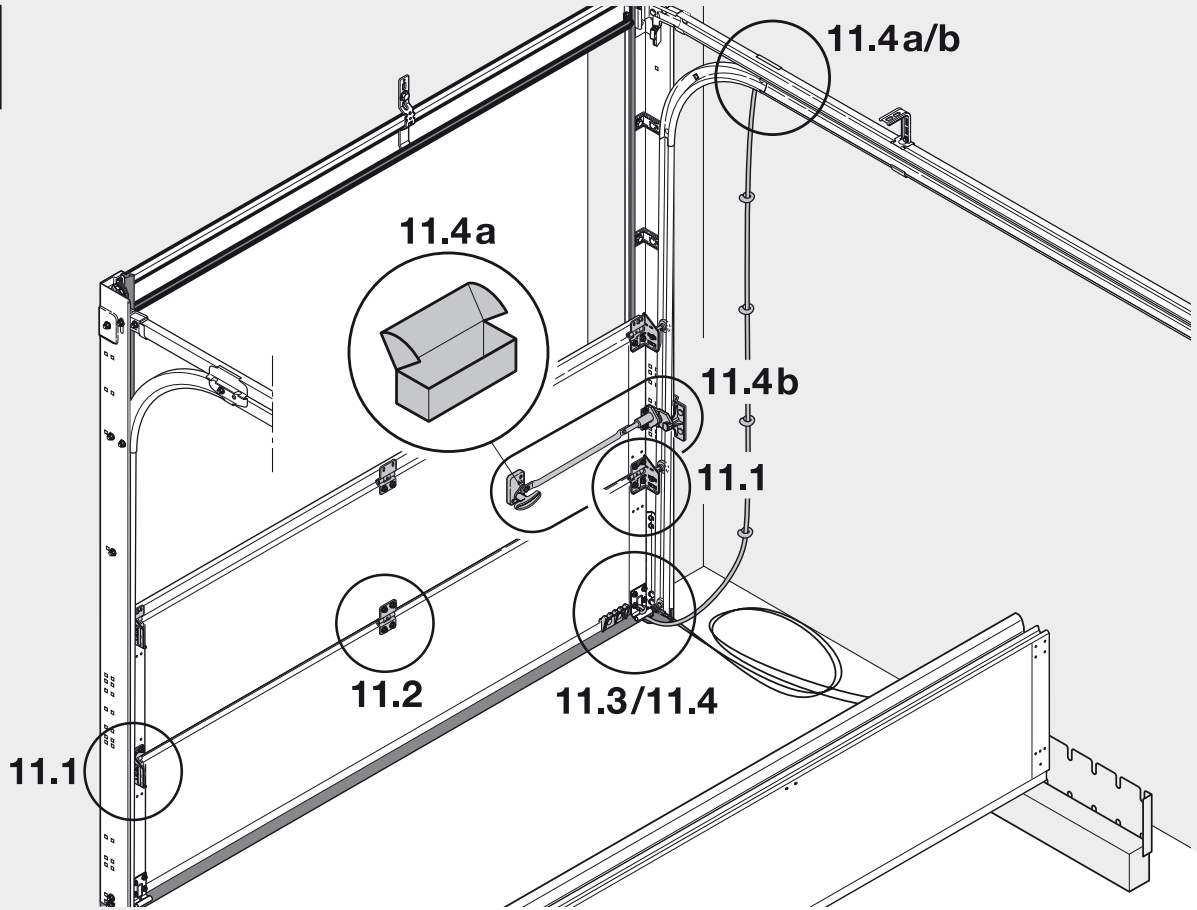

11.1

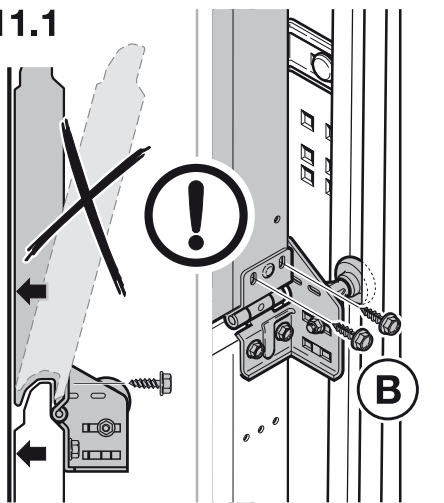

11.2

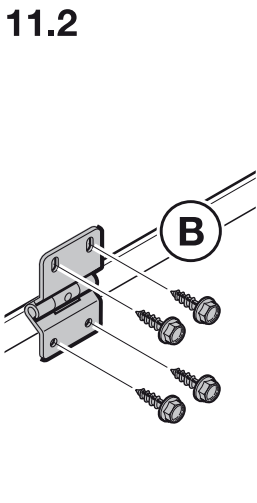

11.4a

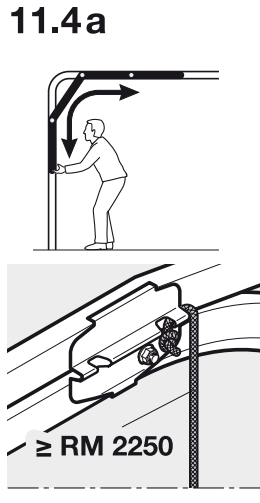

11.4b



11.3a

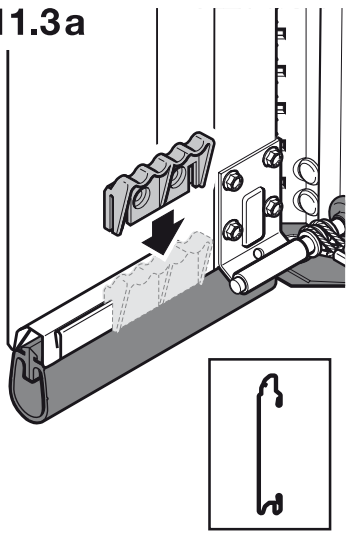

11.3b

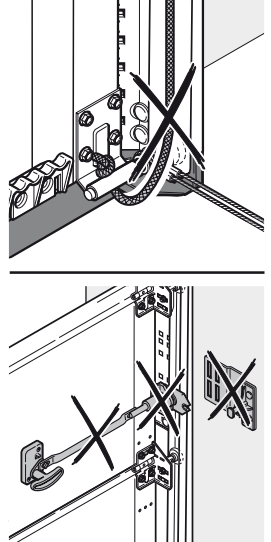
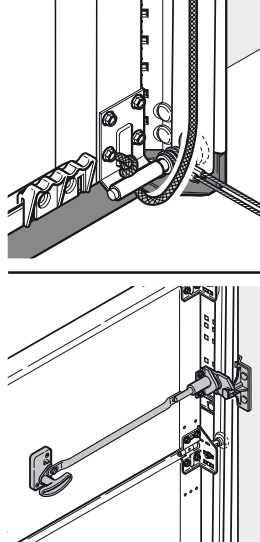
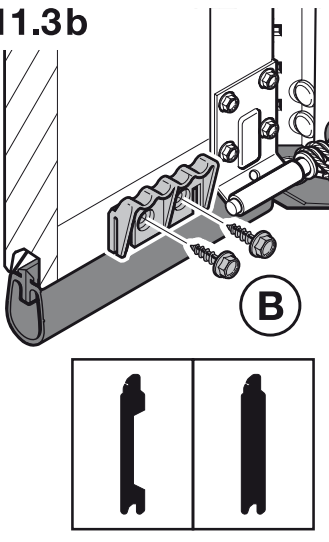



12

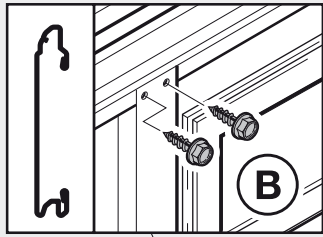

12.1

12.1

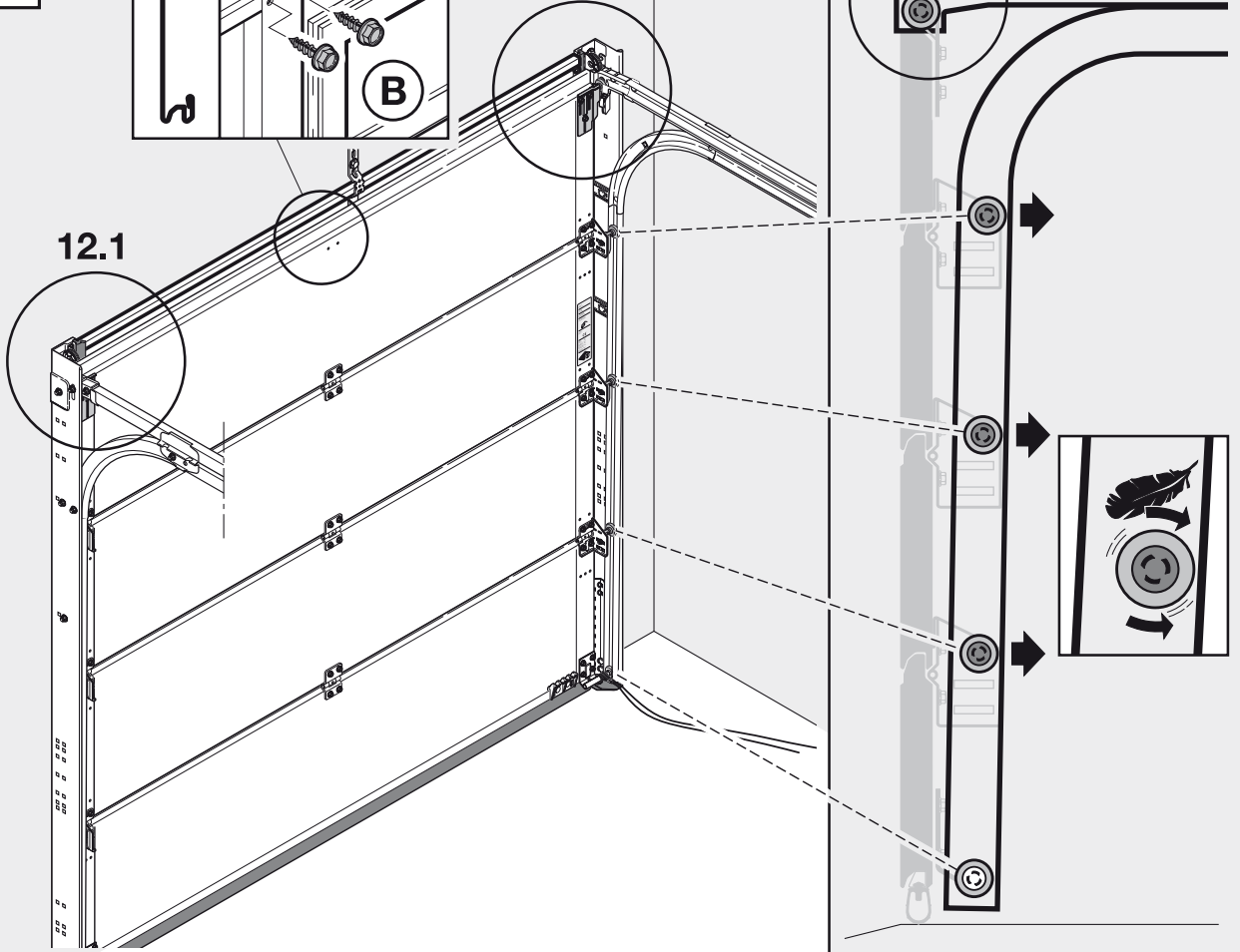

12.1a

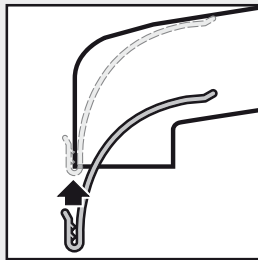
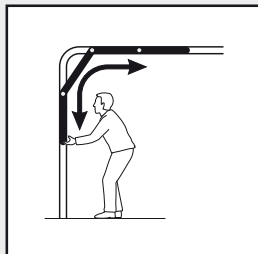
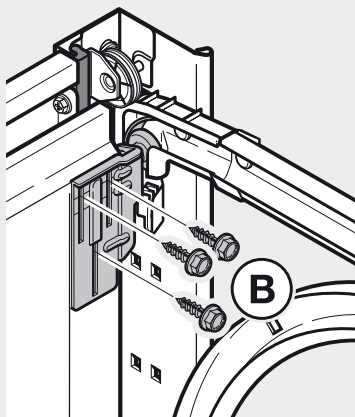

12.1b

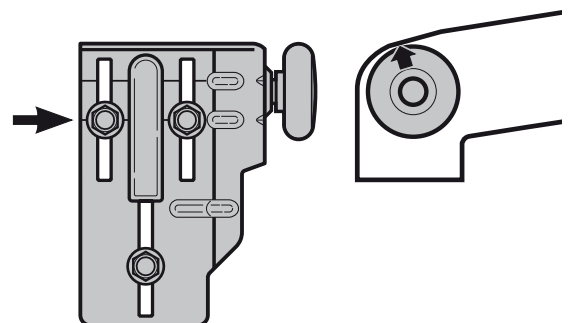
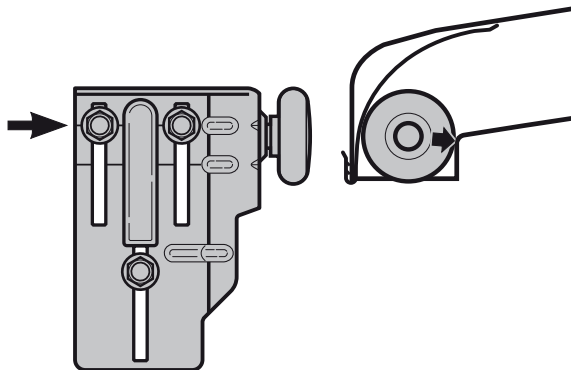
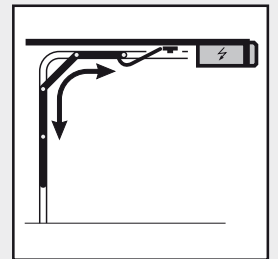
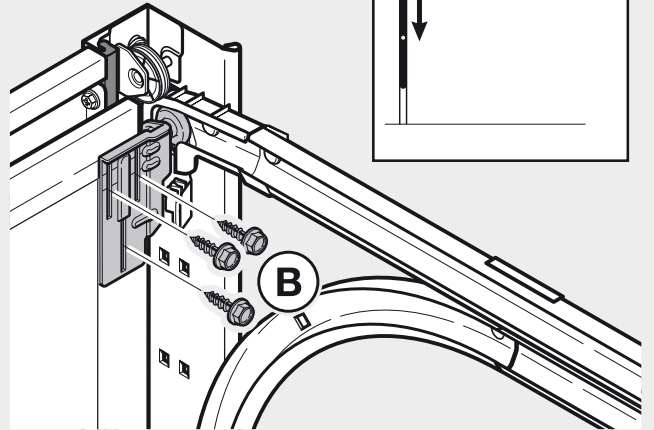

13

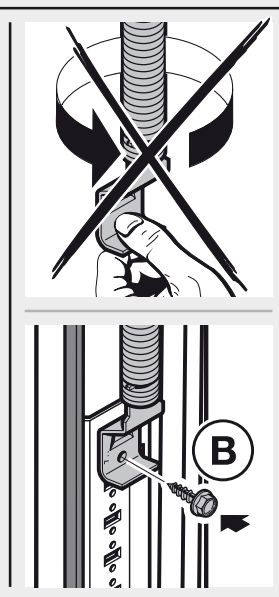
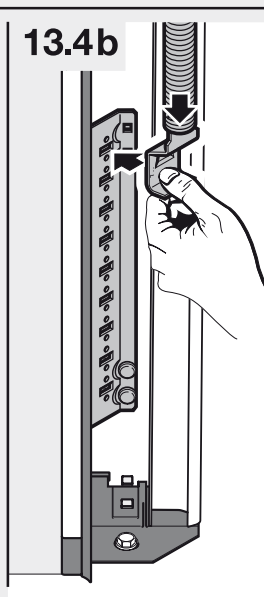
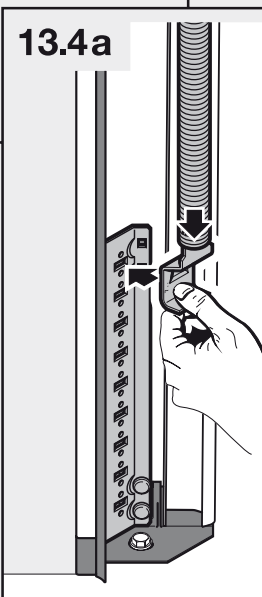
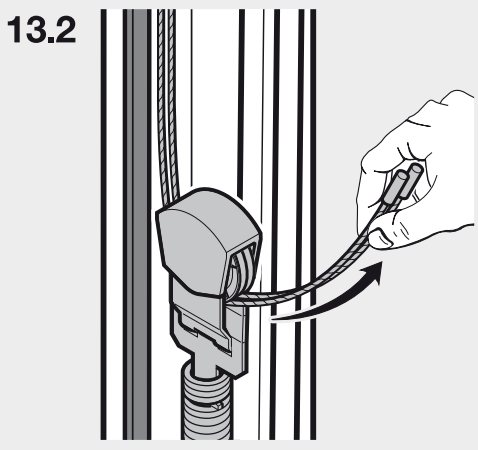
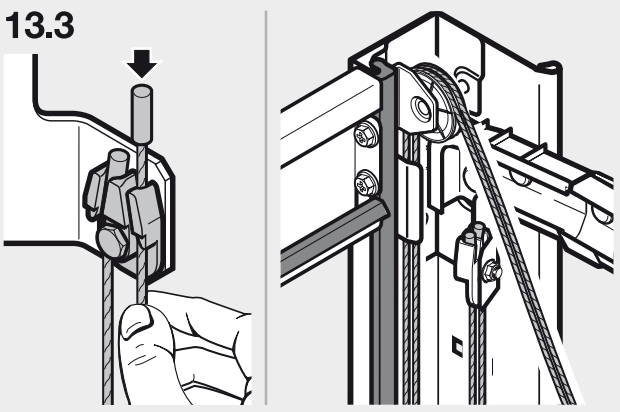
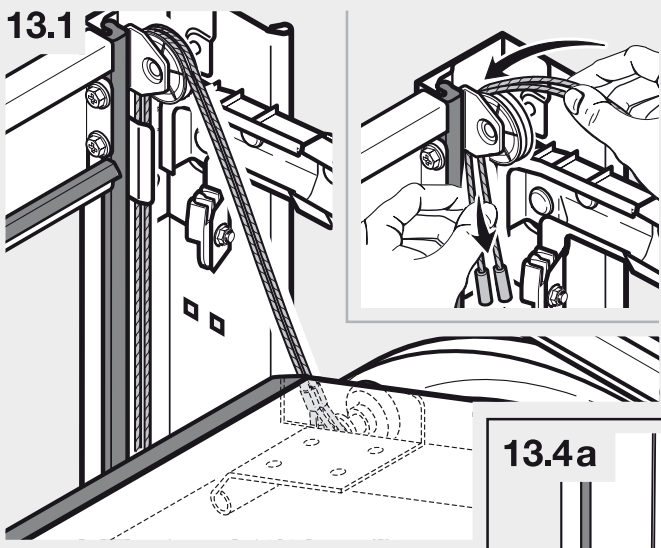
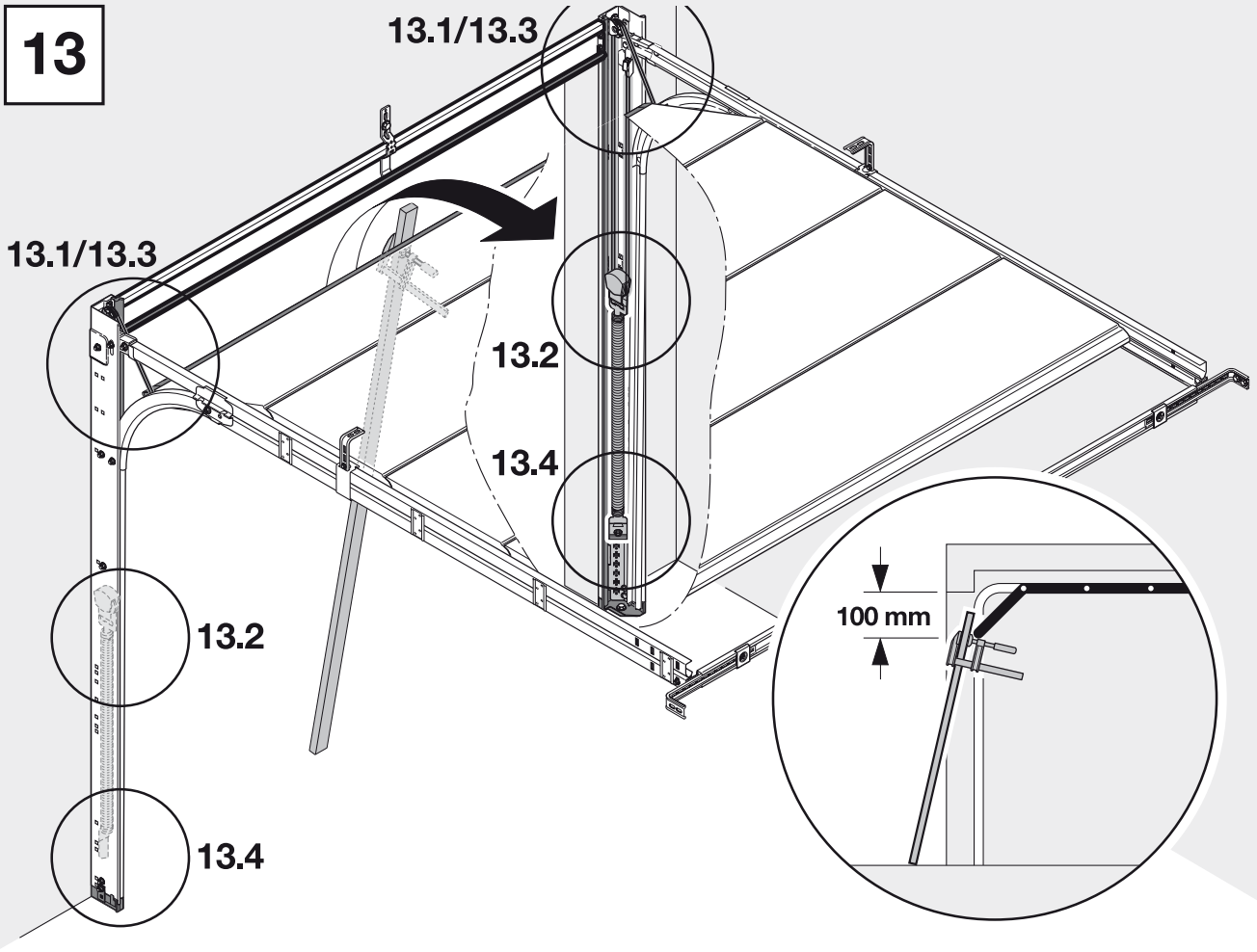

14

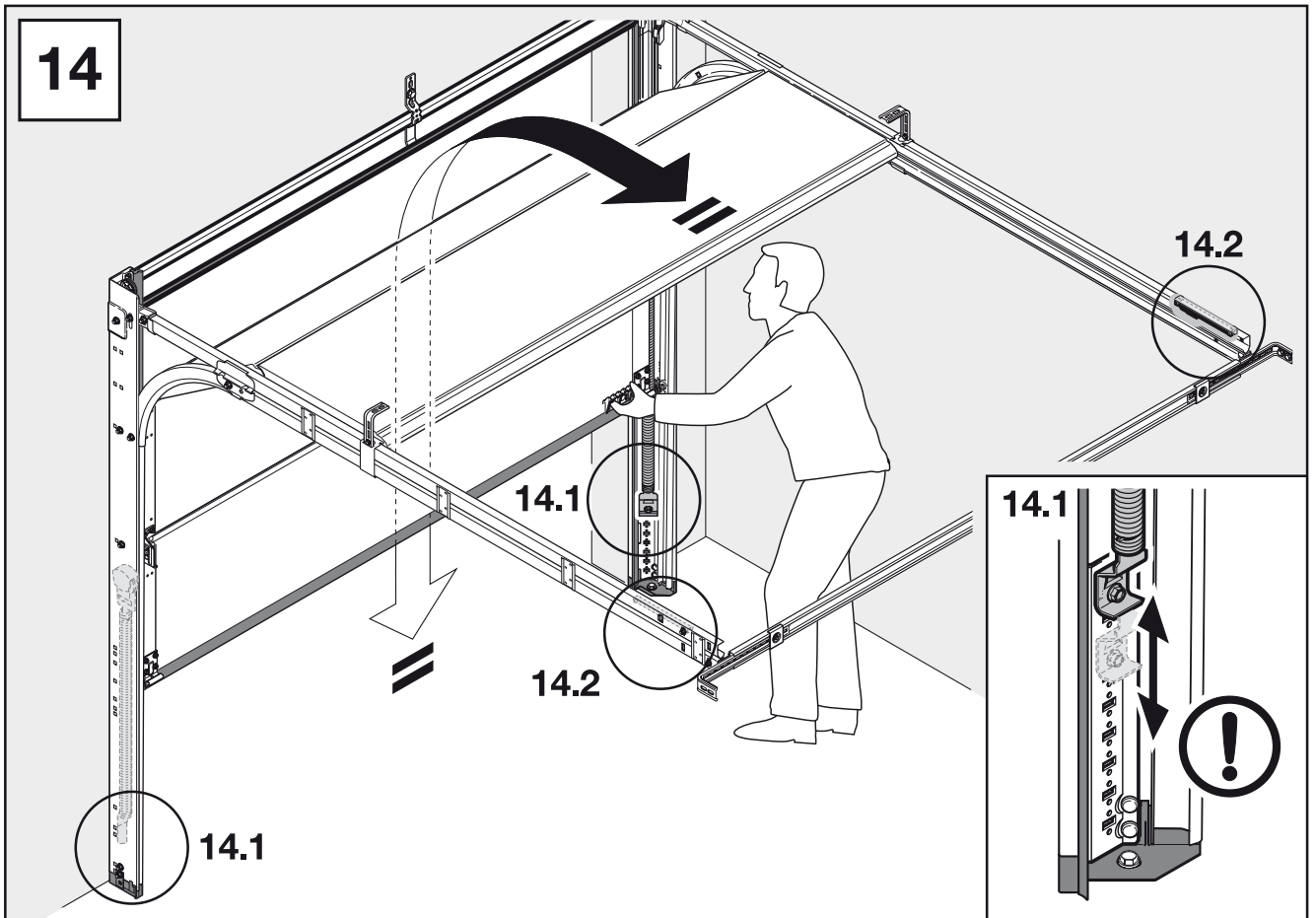

14.2a

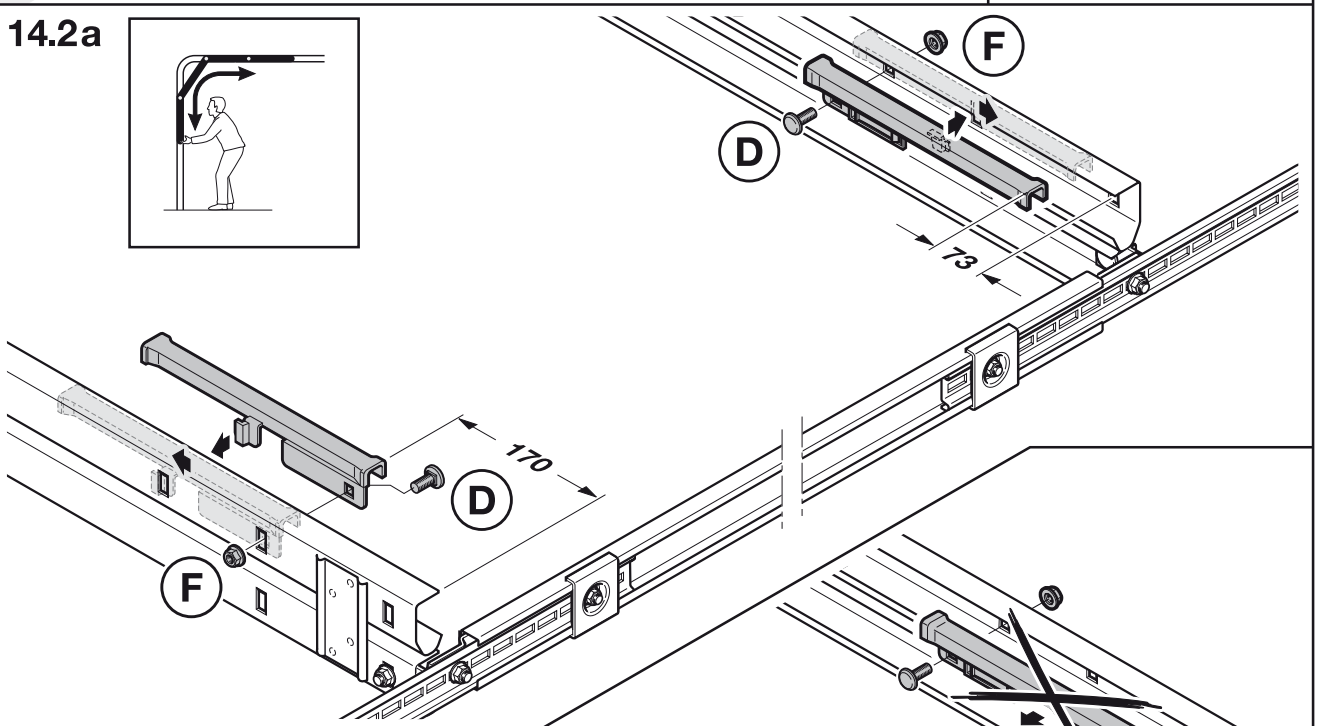
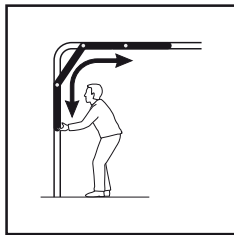

14.2b

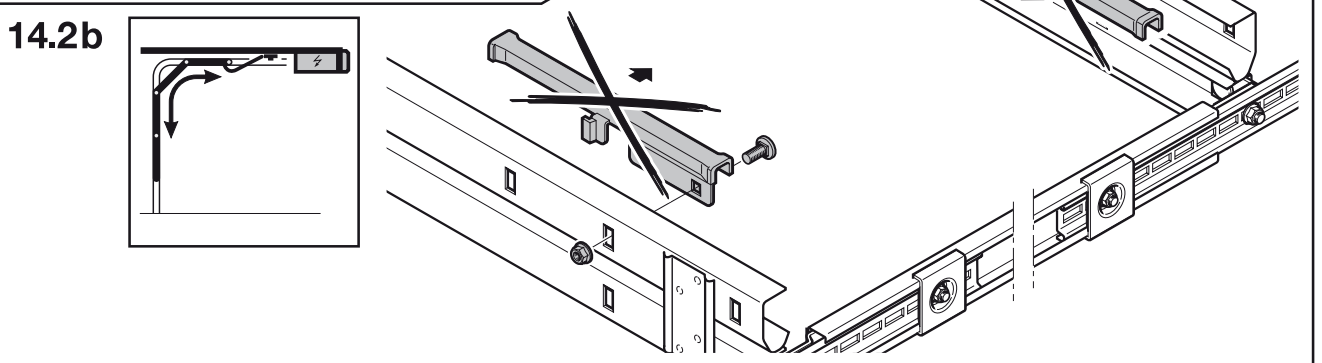
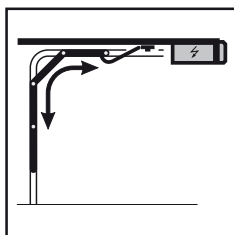

Auftrags-Nr:  
Order No:  
No. de fabrication:

Produkt-Nr:  
Product No:  
No. de produit:

Flügelgewicht [kg]:  
Door weight [kg]:  
Poids de la porte [kg]:

Zugfederpaket Nr:  
Tension spring assembly:  
Colle ressorts de tractions:

**X**



Baujahr:  
Produced in:  
Année:

**CE**

Windlast Klasse:  
Wind load Class:

Wasserdichtheit Klasse:  
Water tightness Class:

Wärmeisolation Klasse:  
Thermal resistance W/m<sup>2</sup>K Class:

Luftdurchlässigkeit Klasse:  
Air permeability Class:

Perméabilité à l'air Classe:

Perméabilité à l'air Classe:

Perméabilité à l'air Classe:

Perméabilité à l'air Classe:

Perméabilité à l'air Classe:

Perméabilité à l'air Classe:

Perméabilité à l'air Classe:

Perméabilité à l'air Classe:

Perméabilité à l'air Classe:

Perméabilité à l'air Classe:

Perméabilité à l'air Classe:

Perméabilité à l'air Classe:

Perméabilité à l'air Classe:

Perméabilité à l'air Classe:

Perméabilité à l'air Classe:

Perméabilité à l'air Classe:

Perméabilité à l'air Classe:

Perméabilité à l'air Classe:

Perméabilité à l'air Classe:

Perméabilité à l'air Classe:

Perméabilité à l'air Classe:

Perméabilité à l'air Classe:

Perméabilité à l'air Classe:

Perméabilité à l'air Classe:

Perméabilité à l'air Classe:

Perméabilité à l'air Classe:

Perméabilité à l'air Classe:

Perméabilité à l'air Classe:

Perméabilité à l'air Classe:

Perméabilité à l'air Classe:

Perméabilité à l'air Classe:

Perméabilité à l'air Classe:

Perméabilité à l'air Classe:

Perméabilité à l'air Classe:

Perméabilité à l'air Classe:

Perméabilité à l'air Classe:

Perméabilité à l'air Classe:

Perméabilité à l'air Classe:

Perméabilité à l'air Classe:

Perméabilité à l'air Classe:

Perméabilité à l'air Classe:

Perméabilité à l'air Classe:

Perméabilité à l'air Classe:

Perméabilité à l'air Classe:

Perméabilité à l'air Classe:

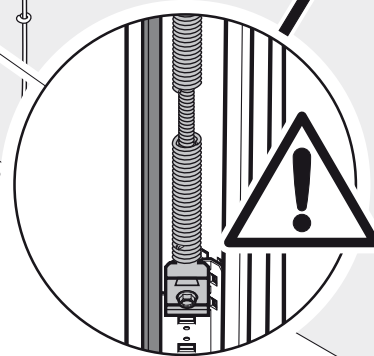
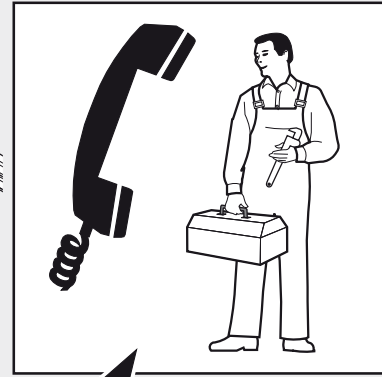
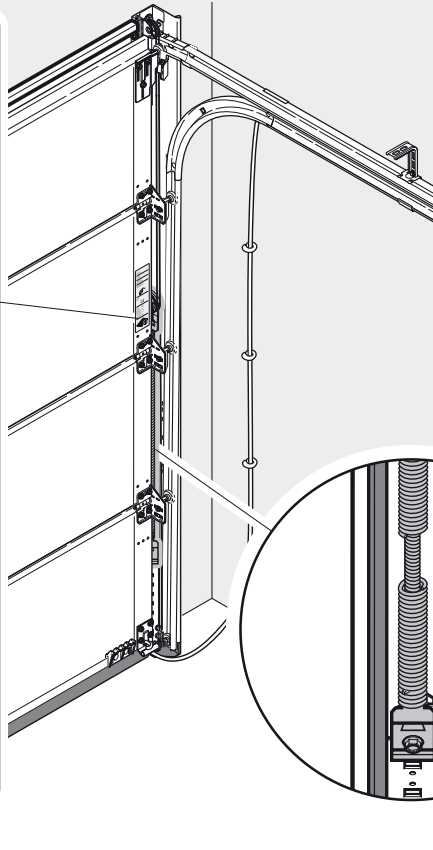

1

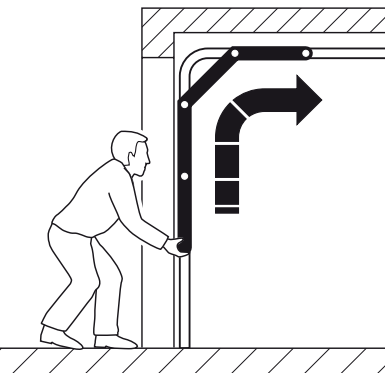

2

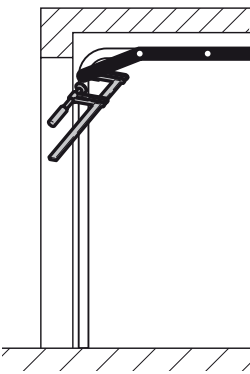

3

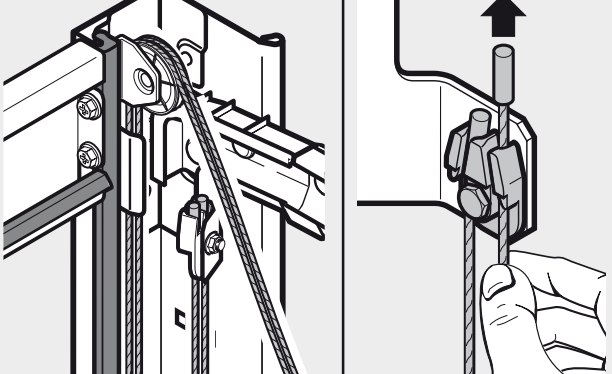

4

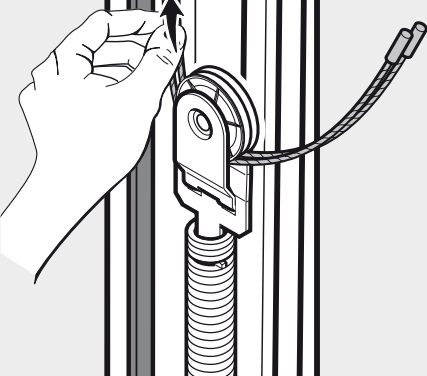

5

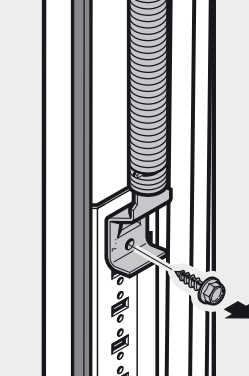

6

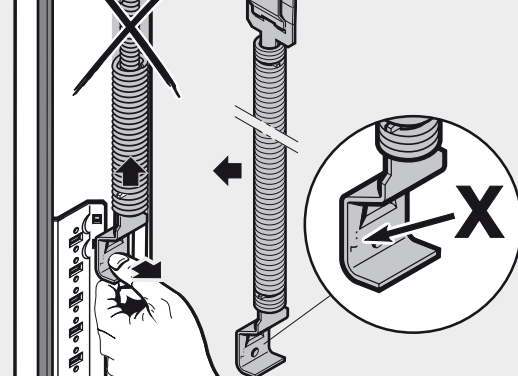

7

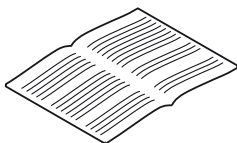

13.2



13.3



13.4



14.1